

Spike

KNEELED



User Manual for Spike (kneeled)

Made by Exero Technologies





Safety

- Use of Spike beyond what is presented in this manual may result in a risk and is not recommended.
- Wear a helmet and reflective vest when using Spike.
- Pay particular attention to any traffic around you and be aware that drivers may have difficulty seeing you. If possible, avoid traffic on busy motorways for your own safety.
- Riding in traffic is considered to be the greatest risk when using Spike.
- Be aware of your roller ski pole usage near other people and the danger of hitting bypassers with your poles..
- Take into account your own skill level when planning your Spike rides.
- Ensure that screws and nuts are tightened in accordance with chapter 4.1 before use.
- Be aware of the risk of clamping your fingers, especially during assembly / disassembly, see chapter 6.4.



USER MANUAL

SPIKE (kneeled)

Here at Exero, we have always enjoyed being physically active, and it's our wish to bring that enjoyment to more people.

Working closely with athletes, we developed Spike to create opportunity and help fulfill wishes and dreams.

We hope you love it as much as we do.

Enjoy!



Spike is CE-marked by directive 93/42/EØF in relation to NS-EN 12182:2012 and NS-EN 14971:2012



www.exerotech.com



exerotech



exero_technologies



hello@exerotech.com



+47 984 900 65



Exero Technologies AS
Fornebuveien 46
1366 Lysaker

Exero Technologies org.nr: 918 613 609



Index

1 INTRODUCTION	9
1.1 Safety warning	10
1.2 Intended use	11
1.2.1 Target audience	11
1.2.2 Application and usage	11
1.2.3 User requirements	11
1.2.4 Disclaimer	12
1.3 Main components	13
1.4 Shipping and handling	14
1.5 Warranty	14
2 SAFETY	15
2.1 General safety instructions	15
2.2 Special safety instructions	16
2.2.1 Especially important - Speed wobbles	16
2.2.2 Especially important - Riding in traffic	20
2.2.3 Especially important - pressure ulcers	20
2.2.4 Especially important - Use of poles	21
2.3 Nuts and bolts	21
2.4 Marking	22
3 BEFORE FIRST USE	22
3.1 Tools	22
3.2 Braking	23
3.3 Steering	25
3.4 Spike adjustments	26
3.4.1 Adjusting seating	26
3.4.1.1 Seat width	26
3.4.1.2 Seat length	26
3.4.1.3 Seat angle	29
3.4.1.4 Knee support	30
3.4.1.5 Calf support	33
3.4.1.6 Seat cushion	35
3.4.2 Adjusting steering	37
3.4.2.1 Steering system	37



3.4.2.2	Wheels	39
3.4.3	Adjusting brakes	39
3.4.4	Adjusting straps	39
3.4.4.1	Hip strap	40
3.4.4.2	Thigh strap	41
3.4.4.3	Foot strap	41
3.4.5	Adjusting poles	42
3.5	Boarding and disembarking	42
3.5.1	Standing position	42
3.5.2	Wheelchair	43
3.6	Recommended equipment	44
3.7	Additional equipment	45
4	CHECKLIST BEFORE EACH USE	48
4.1	Checking nuts and bolts	48
4.1.1	Wheel nuts	48
4.1.2	Nuts and bolts for steering	48
4.1.3	Nuts and bolts for seat arm and seat post	49
4.1.4	Screws for front slider	50
4.2	Checking brakes	51
4.3	Checking straps and strapping	51
4.4	Checking air pressure	51
4.5	Checking steering system	52
5	GET THE MOST OUT OF YOUR SPIKE	53
5.1	Seat angle	53
5.2	Adjusting steering setting	54
5.3	Adjusting pole lengths	55
5.4	Drain tire air for higher resistance	55
5.5	Terrain variations	56
6	STORAGE AND MAINTENANCE	57
6.1	Self maintenance	57
6.1.1	Bearing maintenance	61
6.1.2	Axle maintenance	61
6.1.3	Brake maintenance	62
6.1.4	Cushion maintenance	63
6.1.5	Flat tires	63



6.1.6 Maintenance of mudguards	64
6.2 Authorised maintenance	65
6.2.1 Damaged parts	65
6.2.2 Steering maintenance	65
6.3 Storage and transport	65
6.4 Disassembly and reassembly	67
7 WASTE MANAGEMENT	71
7.2 Waste management	71



1 INTRODUCTION

Read User Manual Spike before using Spike. This will ensure safe use of the product. Read especially chapters 1, 2 and 3 before using the product for the first time. Use procedures in chapter 4 every time the product is to be used.

Digital manual available (www.exerotech.com and www.hjelpemiddeldatabasen.no). This will be regularly updated with eventual revisions. Users are therefore encouraged to keep themselves updated on new developments.

Especially important information in this manual is marked with:





1.1 Safety warning



Exero Technologies has the following introductory recommendations for users:

- 1) Use of Spike outside what is presented in the manual can lead to risk and is not advised. Before use, note especially chapter 2 in this manual for safety.
- 2) Use a helmet and reflectors when utilizing Spike.
- 3) Pay special attention in traffic, and be aware that motorists may have difficulty seeing you. If possible, avoid riding in busy traffic for your own safety.
- 4) Riding in traffic is considered the highest risk in using Spike.
- 5) Be alert when using poles around others, and be aware of the risk of hitting pedestrians.
- 6) Be aware of your own capabilities and adapt to your activities.
- 7) Check that screws and bolts are securely tightened as referenced in chapter 4.1 before use.
- 8) Pay attention to avoid trapping fingers, especially during assembly/disassembly, see chapter 6.4.



1.2 Intended use

1.2.1 Target audience

The target audience for Spike are:

- people with permanent handicaps in the lower half of their body.
- people with temporary injuries in the lower half of their body.
- people looking for alternative ways to exercise.

Spike is firstly made for exercise and staying active where the duration of the activity is dependent on the user's physical capability. This product is not considered a replacement for a wheelchair, prosthetics or similar equipment the user relies on in everyday life.

1.2.2 Application and usage

Spike is designed to be used on off-road surfaces free from ice and snow, such as asphalt, gravel, cobblestone and trails. The Spike user sits in a kneeling position strapped over the hips, thighs and ankles. The upper body is used to create momentum by using roller ski poles, as in cross country.

Steering Spike is done by transferring the weight of your upper body to the side you wish to turn. The most comparable principle for this steering mechanism is use of skateboards.

1.2.3 User requirements

In order to use Spike, the following user requirements are demanded:

- Spike must only be used by people who understand how mounting and dismounting, steering and braking are executed.
- Spike has a maximum user weight of 110 kg or 240 lbs.
- The user must have adequate motor skills to properly use the brakes whilst handling the roller ski poles.
- The user must have adequate motor skills in their upper body to handle steering and maneuvering of Spike.



1.2.4 Disclaimer



As Spike is supplied today it is not intended, tested or approved for any of the following uses. Exero Technologies can not be held responsible for use or damage caused by the following activities or conditions:

- Riding down a slalom hill or similar steep declines, summer or winter, also known as Downhill.
- Riding at speeds exceeding 25 km/h or 15.5 mph. This may lead to loss of control over Spike and other dangerous situations.
- Used in relation to kiting or subsequent sails leading to excessive speed and other dangerous situations.
- Equipping Spike with a motor of any kind. The product is only tested for non-motorised riding.
- Making alterations from the original version or installing other equipment, parts or components than those provided by Exero Technologies or approved by Exero Technologies.
- Repairs or alterations on Spike that are not executed or approved by Exero Technologies. All warranty repairs should be executed by Exero Technologies or a service partner approved by Exero Technologies.
- Circumstances where Spike is used by someone other than the owner/user, unless otherwise agreed upon with Exero Technologies.
- Usage under the influence of alcohol, recreational drugs or other strong medication, as this affects your responsiveness and focus which can potentially harm the user or bystanders.
- Cleaning with products containing acid or alkaline, and cleaning with a pressure cleaner or similar high powered equipment.
- Weight exceeding 110 kg or 240 lbs.



1.3 Main components

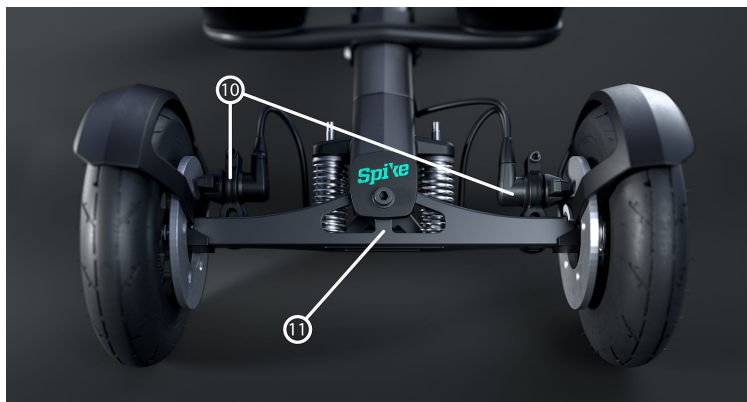

Figure 1.1 - Spike's main components

- | | |
|-------------------------------------|--------------------------------------|
| 1. Adjustable seat w/cushion | 7. Knee support mounted front slider |
| 2. Seat post | 8. Straps for hips and thighs |
| 3. Main fram profile | 9. Seat arm |
| 4. Mud guard | 10. Hydraulic brakes |
| 5. Wheel | 11. Steering mechanism (trucks) |
| 6. Calf support mounted rear slider | 12. Poles w/asfalt-spikes* |



* Associated extra equipment

1.4 Shipping and handling

The following is standard delivery:

- Spike including cushions, straps og screens
- Poles in desired length for user
- User manual

Chosen extra equipment based on personal price quote (see ch. 3.7)

Exero Technologies delivers Spike to the user fully assembled, and to the users address unless otherwise agreed upon. Personal adjustments on Spike can be made before delivery, upon delivery or after delivery, depending on the delivery location. Deliveries in Norway are personally carried out by Exero and Spike will be adjusted upon delivery. For international deliveries, Spike can be adjusted to the user by Exero before shipment, or after by the user themselves through Exero guidelines.

1.5 Warranty

Exero Technologies' warranty is only valid if the product is used in accordance to its intended use and the instructions listed in this manual.

Spike has a 2 year warranty and 5 year guarantee with the exception of considered natural wear and tear from use. *5 year guarantee is assuming the product has had at least 1 service according to the manual, within the 2 year warranty period.* Parts **without** a 2 year warranty and that are expected consumables are:

- Brake pads
- Brake hoses
- Tires
- Poles (incl. asphalt-spikes)



If Spike's functioning is not satisfactory and you live outside of Norway, contact your relevant distributor or Exero directly. If you live in Norway, contact your local NAV Hjelpemiddelsentral or Exero directly.

Exero Technologies AS can be contacted by emailing **hello@exerotech.com** or by calling **+47 984 900 65**.

2 SAFETY

This chapter covers the general and special safety instructions. It is very important that Spike users read the safety instructions before use to reduce risk of accidents and injuries.

2.1 General safety instructions



As with other physical activity, there is a degree of risk when using Spike. It is important for you, as the user, to familiarise yourself with the dangers and take the correct precautions stated in this manual. Here are some general safety instructions the user should be aware of on what can occur when using Spike:

- Spike must only be used in accordance with the instructions provided in this manual.
- Spike can tip over. Familiarise yourself with the use of weight distribution, and be especially aware of this when riding in rough terrain.
- Spike must only be used by one person at a time.
- Spike must not be used by anyone other than the user it was purchased for, unless otherwise agreed upon with Exero Technologies.
- Spike must not be used in stairways.
- Spike must not drive over obstacles in steep declines. High speed and running over obstacles can create stability changes and lead to tipping or crashing.



- Avoid boarding and disembarking Spike in hills.
- Avoid parking in hills with an incline larger than 10 degrees despite the handbrake being on.
- Seat cushions, knee- and calf supports are flammable, and must therefore not be near open flame.
- If parts of Spike are damaged or worn out, they must be changed before continuing use to avoid damages on people and material.
- Engaging in physical activity while strapped in can provoke spasms. We therefore recommend people who often experience spasms to contact a doctor, physical- or occupational therapist before use.
- Avoid storing Spike in direct sunlight, and be aware that use in direct sunlight can lead to hot surfaces.

2.2 Special safety instructions



This chapter presents four special safety instructions that we ask you, as the Spike user, to read carefully before use. These are instructions that may be new to many and concern **1) Speed wobbles**, **2) Riding in traffic**, **3) Pressure ulcers**, and **4) Use of poles**.

2.2.1 Especially important - Speed wobbles



Like with skateboards, uncontrolled swings in the steering mechanics- *speed wobbles*- can occur with Spike. This is due to the steering mechanism's principle, with springs that rely in part on the speed and weight distribution of the product. By *speed wobbles* we mean how the product can feel unstable in high speeds. This can lead to the user losing control of Spike and in the worst case be subject to an accident. It is therefore vital that the user reads this chapter on speed wobbles before using Spike for the first time. Figure 2.2.1 shows how Spike turns from side to side. Contact Exero Technologies for more information.

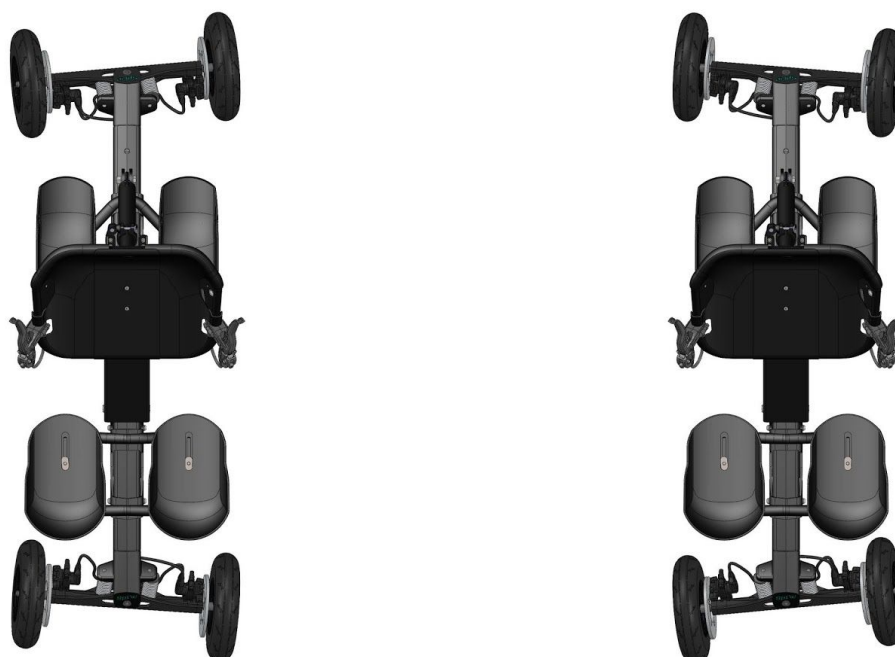
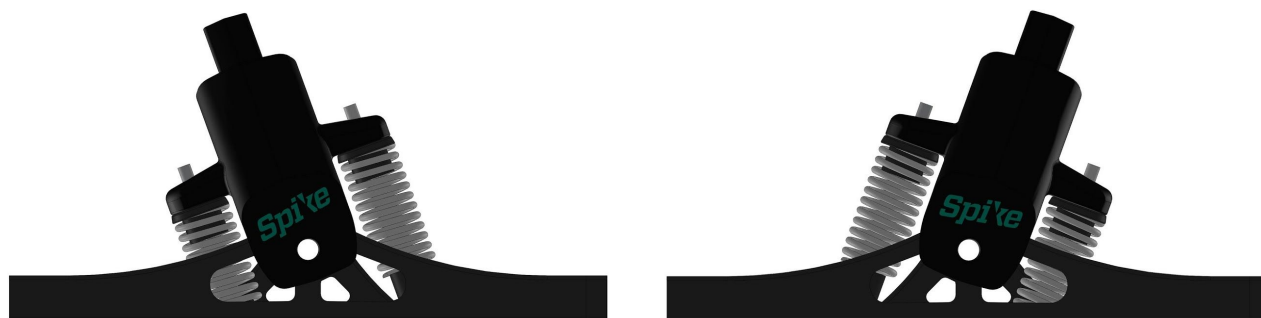

Figure 2.2.1 - Illustration showing the steering principle.

There are mainly three factors the user must be cautious of to avoid speed wobbles; speed, setup of steering system, and sharp movements.

Speed

The most important factor to avoid speed wobbles is to limit your speed. The higher the speed, the higher the likeliness of losing control. With this in mind Exero Technologies has set a recommended maximum speed at **25 km/t** or



15.5 mph, but beginners are cautioned to start slowly and feel it out. Should speed wobbles occur it is vital to engage brakes and lower speed.

Setup of steering system (trucks)

Another factor that is customisable is the setup of the steering system. Spike has four individual springs, two in front and two in the back which are adjustable. In general, a tighter setup should reduce the likeliness of speed wobbles in lower speeds. This can be done in the following two ways:

1. Tighten the springs by turning the adjustment bolts, see ch. 3.4.2 *Adjusting steering*. By turning adjustment bolts clockwise, the springs will tighten and the setup of the steering system will be harder. This reduces the swing radius, but increases control in higher speed. You should therefore adjust this to fit the speeds you intend on reaching. Higher speeds should have tighter springs.

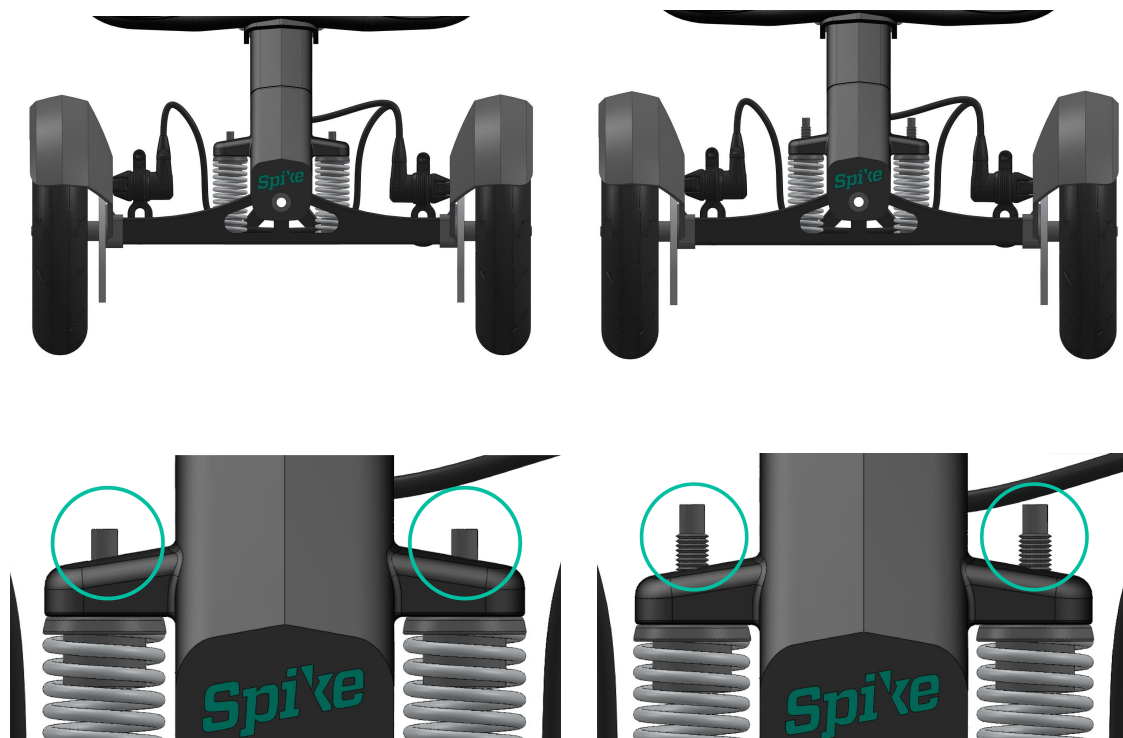

Figure 2.2.2 - Adjustment bolts in tight (left) and loose (right) positions.





IMPORTANT! To avoid speed wobbles the rear springs on Spike should be tighter than the front springs.

2. To further stiffen the steering system, the rubber dampers can be changed. These are designed to absorb vibrations in the steering system and can be changed to accustom the riding style. They can be found in five variations with differing resistance, yellow being the lowest resistance and white the highest, see figure 2.2.3. Spike is delivered with red shocks (medium), but this can be customised. The lowest resistance (yellow and green) are usually best suited for lighter users, beginners or those desiring a better swing radius. The highest resistance (blue and white) are best suited for heavier and more experienced users who desire higher speed and rigidity.



Figure 2.2.3 - Rubber dampers with varying resistance
Source: Trampboards.com



IMPORTANT! Regardless of your setup, high enough speeds will cause speed wobbles. Adjusting the setup of your steering system will not remove the risk of speed wobbles entirely.

Avoid sharp movements in high speeds

The last factor concerning speed wobbles is the users movements at speed. The user will obtain the best control with softer movements, especially when gaining speed. Like with any activity, mastering Spike requires practice and experience. We therefore encourage the user to start gently and try their way forward to discover their own limitations as well as Spike's.



2.2.2 Especially important - Riding in traffic



When using Spike you are sitting low, something that can make it difficult for motorists to spot you. It is therefore vital to show diligence and caution when using Spike in traffic. When used on public roads the user must follow appropriate law.

If Spike is used in busy areas, it is recommended to utilise a reflective vest and pennant for better visibility. It is recommended to use a helmet when using Spike in any capacity. It is particularly important when riding in traffic to ride according to the conditions, where weather can lead to weakened visibility.

2.2.3 Especially important - pressure ulcers



People who often experience getting pressure ulcers should consult with their doctor or occupational therapist (OT) before using Spike. Factors that are likely causes of pressure ulcers are listed below:

- Time is a deciding factor for the formation of pressure ulcers, and the likeliness increases when sitting in the same position over an extended period of time. Spike is equipped with pressure-easing cushions and pads, but with people who have high risk of getting ulcers we recommend consulting with an OT or doctor before use. Based on experience and user testimonies for Spike, 20-180 min is considered to be a natural duration per session.
- If Spike has been exposed to rain or moisture, we ask the user to make a precautionary assessment of whether or not the product can be used. Moisture can raise the risk for ulcers if the skin is exposed over longer periods. The same applies to sweat or wet clothes, the user is therefore recommended to use dry clothes when able.
- Friction can be a likely cause for ulcers developing. To avoid unnecessary friction, Spike is equipped with strong straps that can be tightened well.



Meaning that the user can strap themselves in a way that creates minimal movement between the body and Spike. This will contribute to reducing the likeliness of ulcers developing.

2.2.4 Especially important - Use of poles



To create forward propulsion, the poles are planted in the ground simultaneously on each side of Spike. The user should only use poles when safe and responsible conditions. The poles have sharp asphalt-spikes for optimal surface grip, which also demand caution to avoid injury, see figure 2.2.4. If the user is riding in populated areas we recommend practicing caution and lowering speed, as others can be struck. When braking the poles must be held backwards to avoid injuring others. The user should not use poles where the spikes can damage the surface, for example on an indoor course. When transporting Spike it is recommended to blunt the spikes to avoid accidents.



Figure 2.2.4 - Asphalt spike

2.3 Nuts and bolts



As a safety precaution we recommend checking that nuts and bolts are securely tightened. Over time it is natural that screws and bolts can loosen from



vibrations and during assembly/disassembly. Particularly important screws and bolts are described in chapter 4.1 so the user can check these each time before use.

2.4 Marking

Every Spike has an individual serial number which can be found underneath the main frame profile, see figure 2.4.

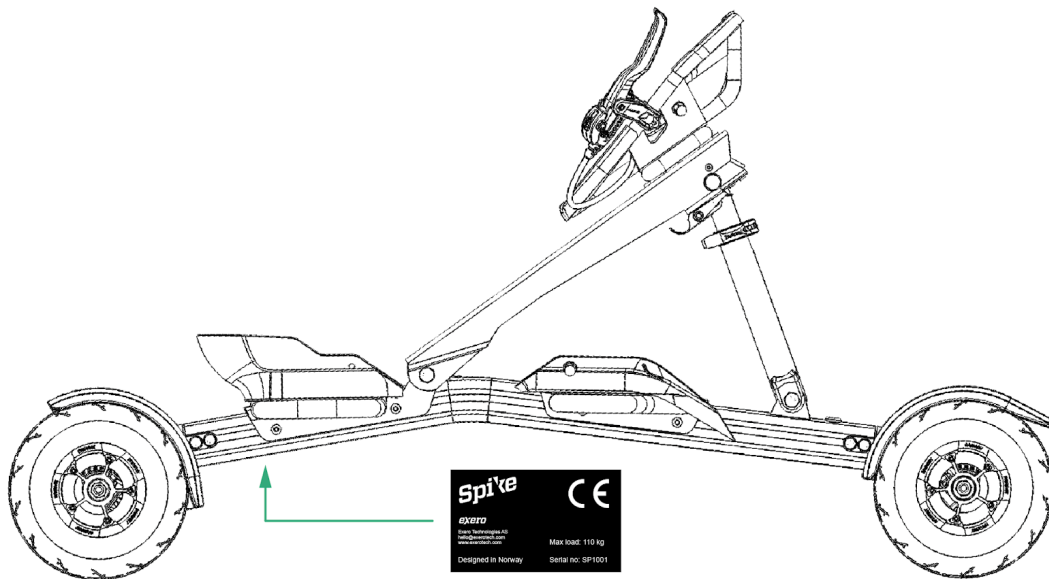

Figure 2.4 - Location of serial number and CE-mark

3 BEFORE FIRST USE

Before using Spike it must be inspected and checked that it is complete. All screws must be tightened and checked up against the safety instructions in chapter 4.1 of this manual.

3.1 Tools

The following tools are necessary to adjust and maintain Spike as described in the following chapters:

- Bike pump
- Pump for adjusting seat cushion
- Hex key 3 mm



- Hex key 4 mm
- Hex key 5 mm
- Wrench 7 mm
- Wrench 10 mm
- Wrench 13 mm
- Wrench 16 mm
- Torx T25
- Adjustable spanner
- Thin oil (example WD-40 eller CRC 5-56)

3.2 Braking

Before using Spike for the first time, and to avoid unwanted incidents, it is important to familiarise yourself with how the brakes work, see figure 3.2.1. Spike's brakes are similar to those on mountain bikes, see figure 3.2.2. Spike has two brake handles, one on each side of the seat. The left handle controls the front wheels and the right handle controls the back wheels. Each brake handle has a parking brake, see figure 3.2.3. Spike has hydraulic brakes that brake powerfully if correctly adjusted, and it is important that the user tests their response before use. Gradually push the brakes down. You should clearly notice that the brakes engage and movement stops. Make sure to keep your poles pointed behind you while braking.



IMPORTANT! *By slamming the brakes the wheels may lock.*

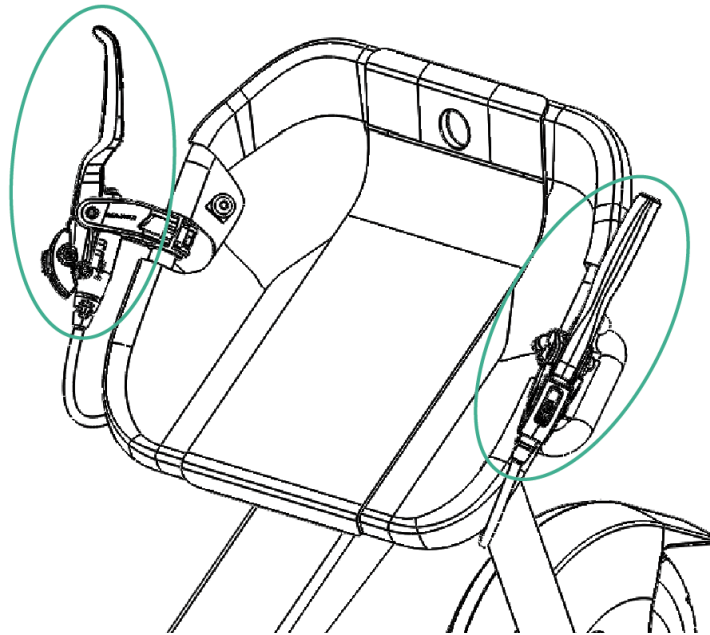

Figure 3.2.1 - Brakes on Spike

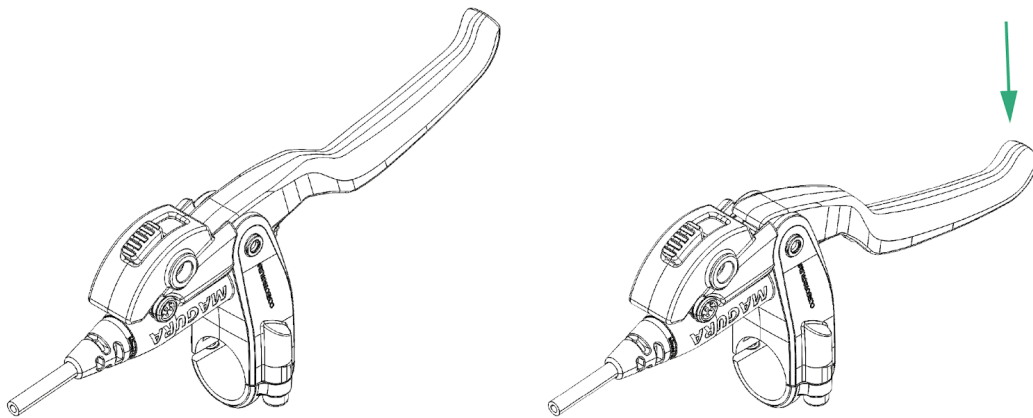

Figure 3.2.2 - Step by step how Spike's brakes work.

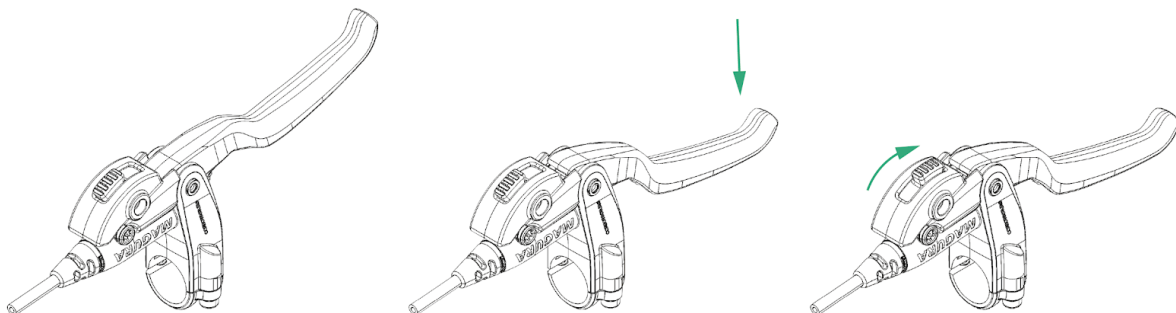

Figure 3.2.3 - How to lock brakes



3.3 Steering

Before using Spike for the first time it's important that you familiarise yourself with how the steering mechanism works, see figure 3.3.1. To avoid unwanted incidents it's important to carefully feel your way forward the first few rides. The principle for steering Spike is similar to that of a skateboard. Meaning the user has to lean to a side to initiate a turn. To complete a turn it's important to continue to lean to the side until you wish to straighten Spike. A common mistake at first is straightening too early and cutting the turn short.

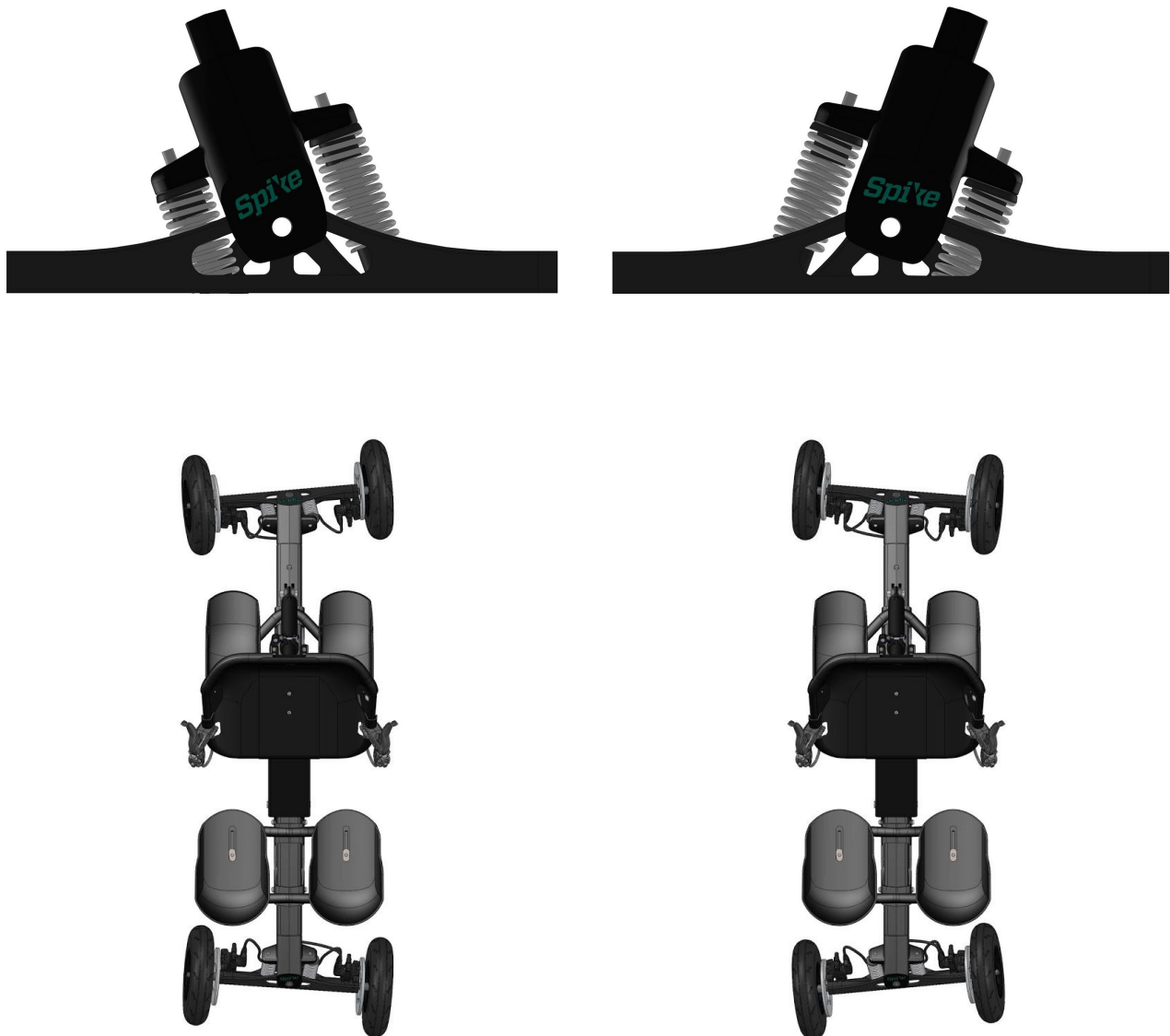

Figure 3.3.1 - Illustration that demonstrates steering mechanics.



3.4 Spike adjustments

When adjusting Spike to the user the following must be observed:

- Body length and weight (max capacity 110 kg or 240 lbs)
- Physical and mental condition
- Surroundings (especially concerning riding in traffic and surface)

Spike can be adjusted in several ways and the following parts are adjustable: seating position, steering system, straps, brakes and poles. With all adjustments where screws and bolts are loosened, ensure that they are securely screwed back before use. In the following paragraphs we cover the various adjustments.

3.4.1 Adjusting seating

3.4.1.1 Seat width

Your seat width should be adjusted according to your hip width. First, remove the seat cushion and the black, plastic seat shells by pulling apart the velcro connections. Then, loosen the four nuts underneath the seat, see figure 3.4.1. Use a **10 mm** wrench. Nuts must be completely screwed off and bolts removed. Align the two holes on the seat frame with two of the seven holes on the adjustment frame. There are five different combinations. Right and left sides of the seat are adjusted separately. When each part is in its desired position, push the bolts back in the track and tighten the nuts well. Put the plastic seat shells and seat cushion back in place and pump your cushion again if needed, see chapter 3.4.1.6.

3.4.1.2 Seat length

The seat length should be adjusted according to your thigh length in relation to knee supports. First, remove the seat cushion and the black, plastic seat shells by pulling apart the velcro connections. Then, loosen the two nuts underneath the seat, see figure 3.4.2. Use a **10 mm** wrench. Nuts must be completely screwed off and bolts removed. The whole seat will be free to move to any of the ten different adjustment holes. When the seat is in its desired position, push the bolts back in the track and tighten the nuts well. Put the plastic seat shells and



seat cushion back in place and pump your cushion again if needed, see chapter 3.4.1.6.

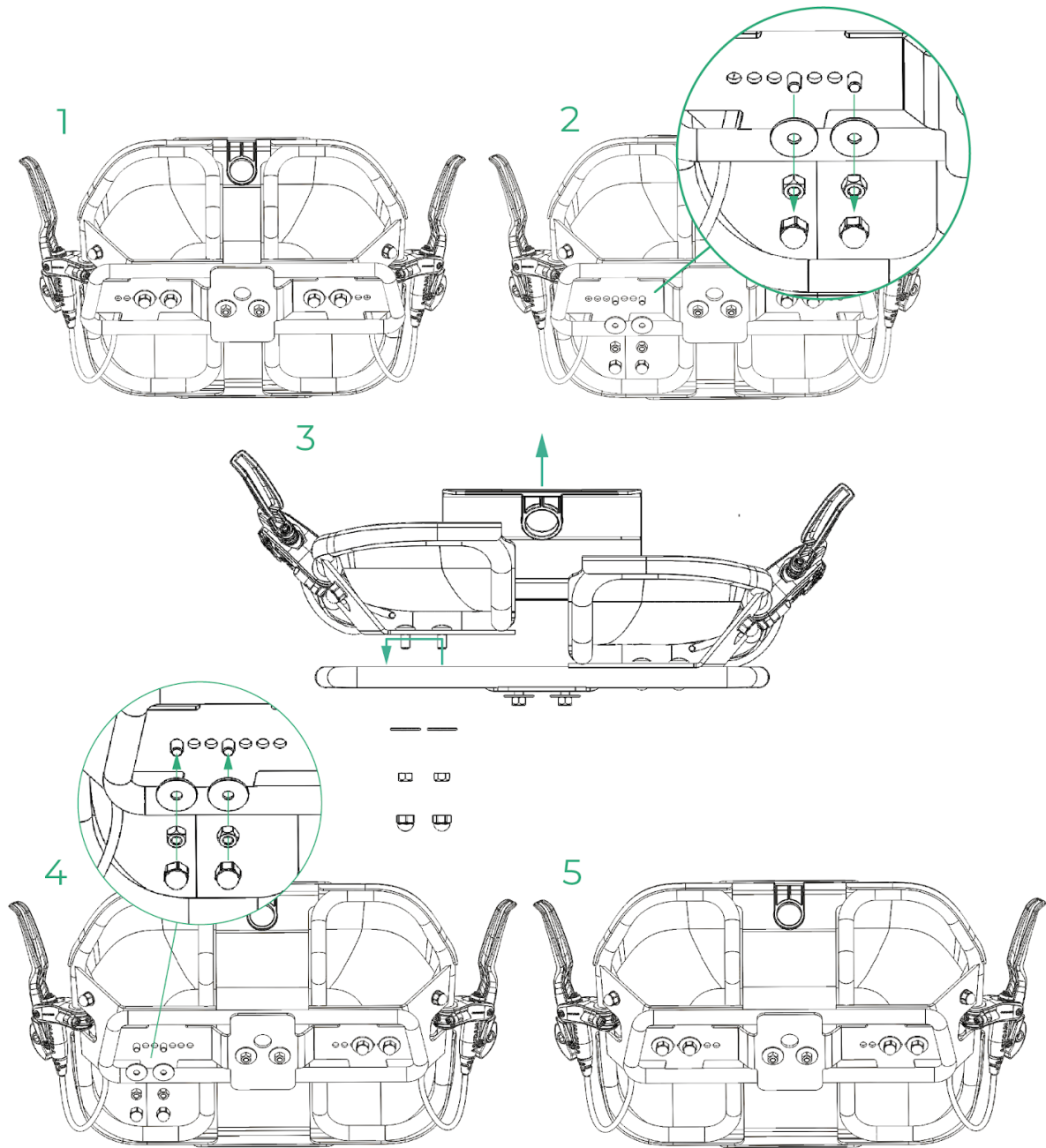

Figure 3.4.1 - Adjust seat width

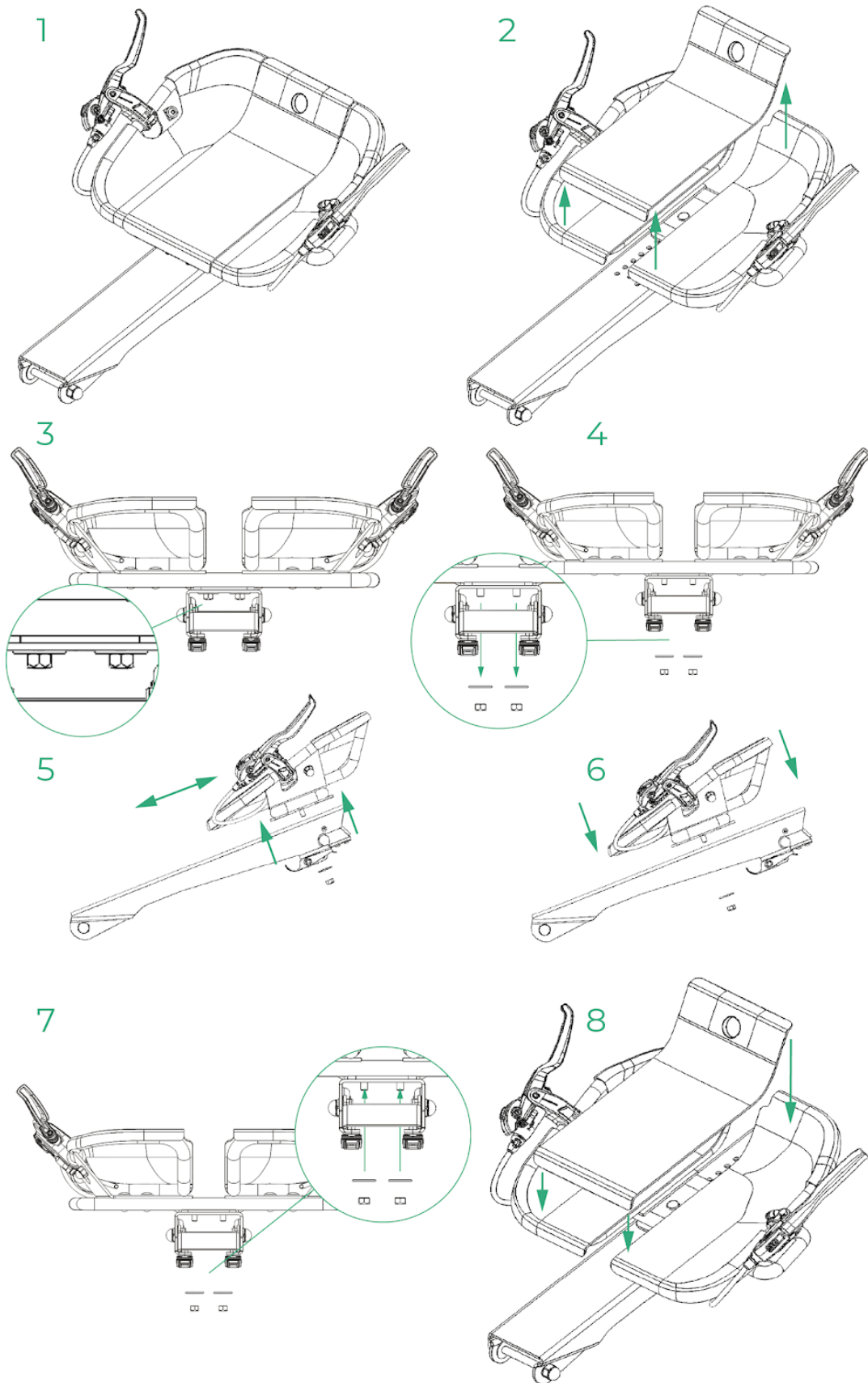

Figure 3.4.2 - Adjust seat length



3.4.1.3 Seat angle

The seat angle can be adjusted to the user's sitting position. A steeper angle provides a more active seating position with most of your weight on your knees. A lower angle provides a more passive position with more weight on your rear. Benefits and disadvantages of the different angles are explained in chapter 5 - *Seat angle*. The seat angle is adjusted by loosening the seat clamp under the seat so the whole seat can be pushed up or down, see figure 3.4.4. When the seat angle is adjusted accordingly, tighten the clamp well.



Important! The seat post has a circle that marks maximum adjustable length. See figure 3.4.3

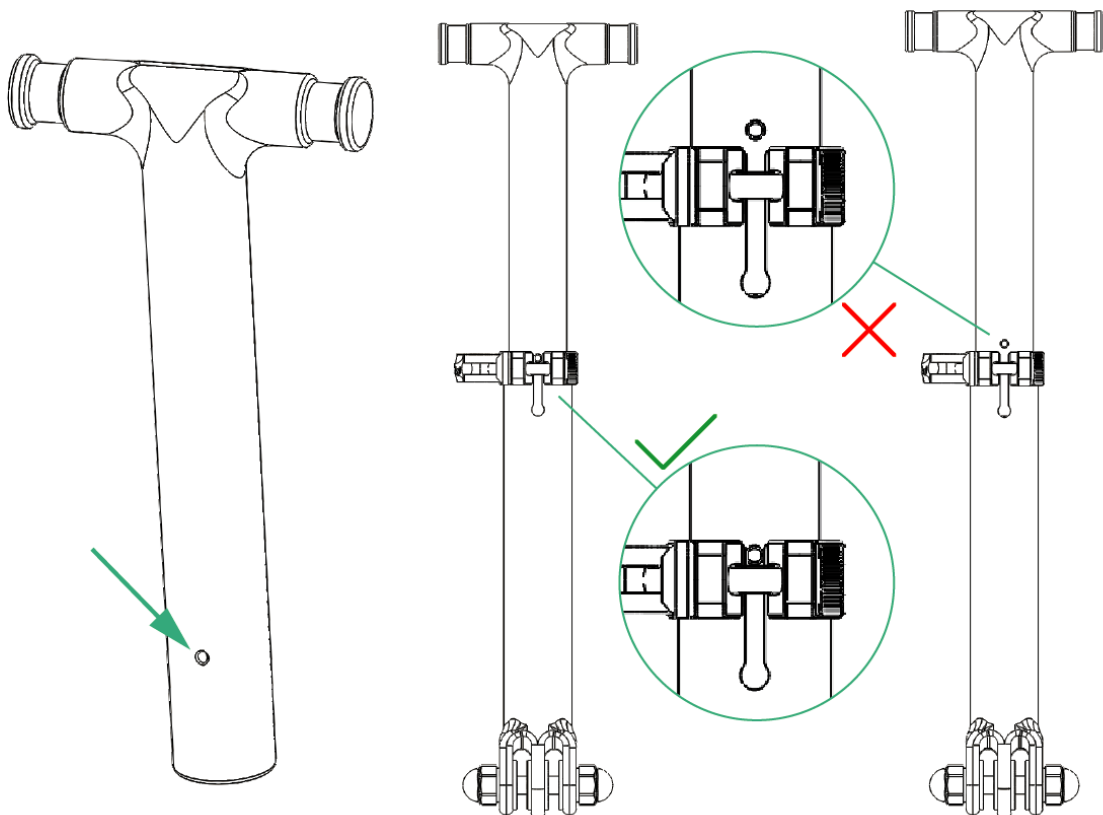

Figure 3.4.3 Seat post markings

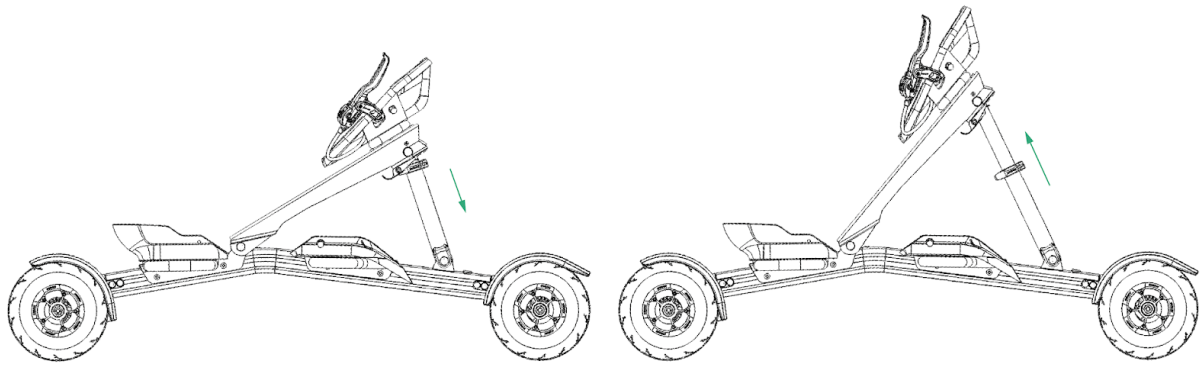

Figure 3.4.4 - Adjust seat angle



Important! Risk of trapping fingers when adjusting seat, see figure 3.4.5.



Figure 3.4.5 - Risk of trapping fingers

3.4.1.4 Knee support

The knee support should be adjusted according to your calf lengths in relation to the calf supports or thigh lengths if you don't want to adjust the seat. There are



two knee pads on Spike attached to the front slider. The knee pads can be adjusted in the following ways;

1. **Adjust front slider** by loosening four screws (hex key **4 mm**), see fig 3.4.5. The slider can be pushed along the track on the main frame profile. The seat angle will alter when the front slider is moved. When the front slider is adjusted to the desired position, tighten the screws well.

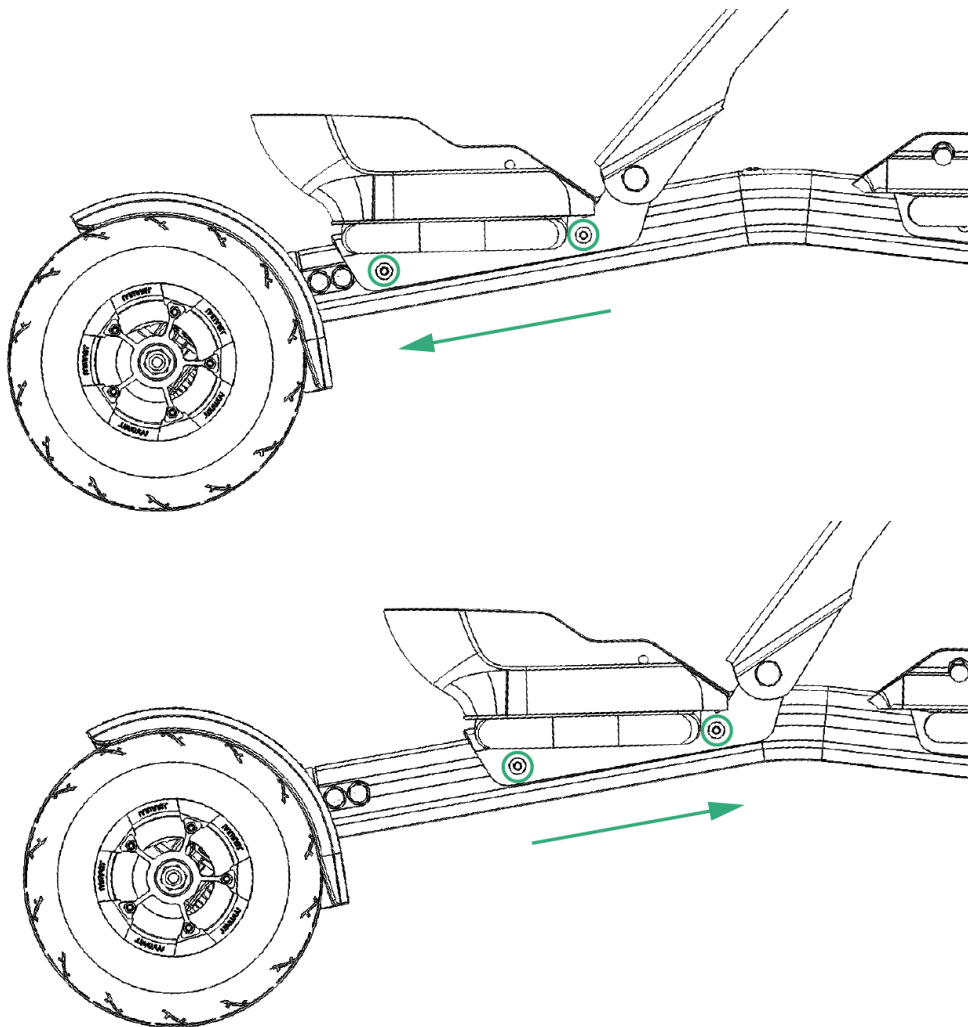

Figure 3.4.5 - Adjusting front slider

2. **Adjust individual knee pads** by loosening the screws marked with a green circle (hex key **4 mm**), see figure 3.4.6. The screw must not be completely screwed off, just loosened. Push the knee pad along the track on the front slider. This can be done individually for each knee pad. This is beneficial



for users with differing thigh and calf lengths. When the knee pads are adjusted to the desired positions, tighten the bolts well.

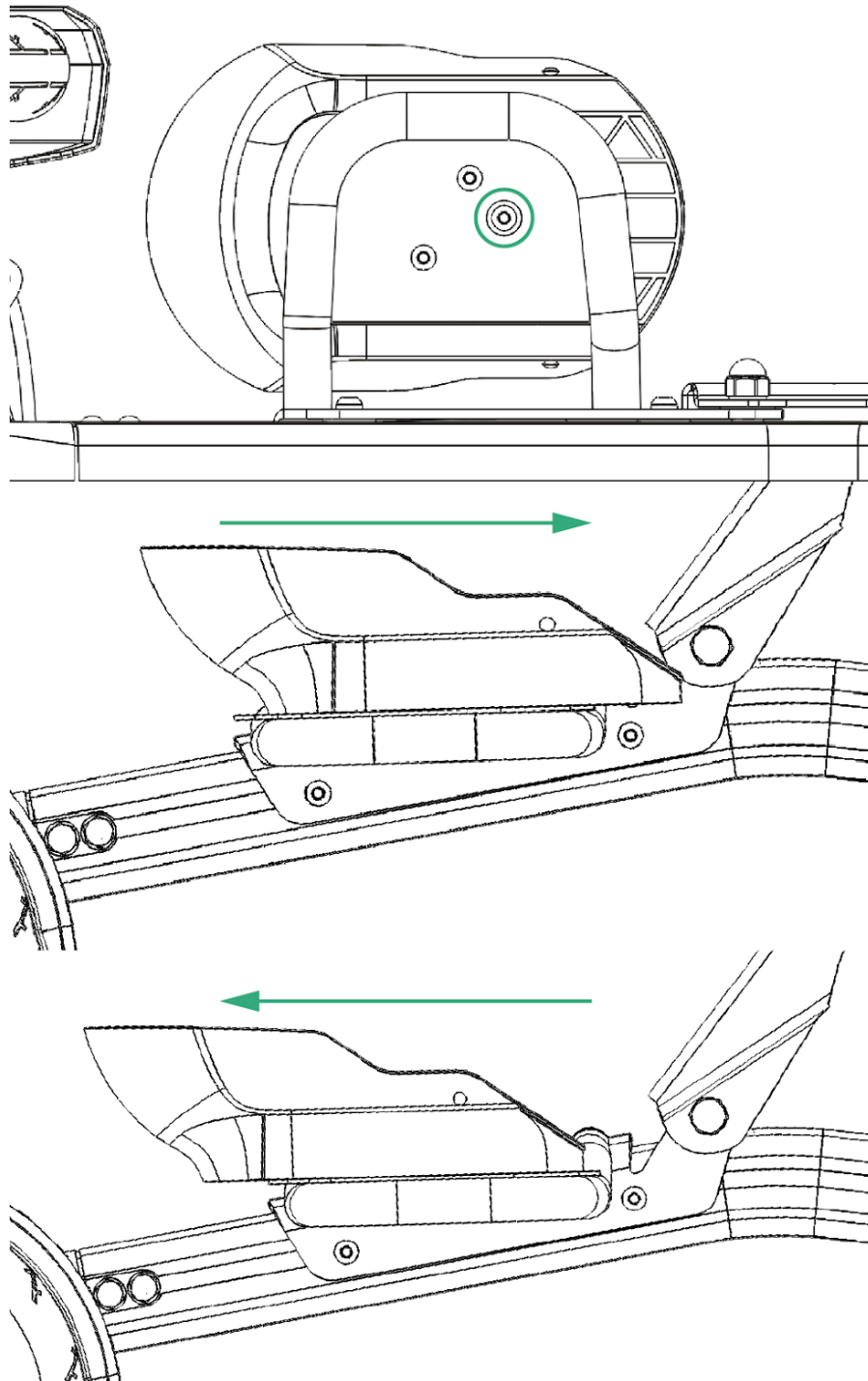

Figure 3.4.6 - Adjusting individual knee support



3.4.1.5 Calf support

The calf support should be adjusted according to the users calf lengths or placement of feet. There are two calf supports on Spike, attached on each side of the rear slider, see figure 3.4.7. Calf supports can be adjusted in two ways;

1. **Adjust rear slider** by loosening four screws (hex key **4 mm**), see figure 3.4.6. The slider can be pushed along the track on the main frame profile. When the rear slider is adjusted to the desired position, tighten the bolts well.

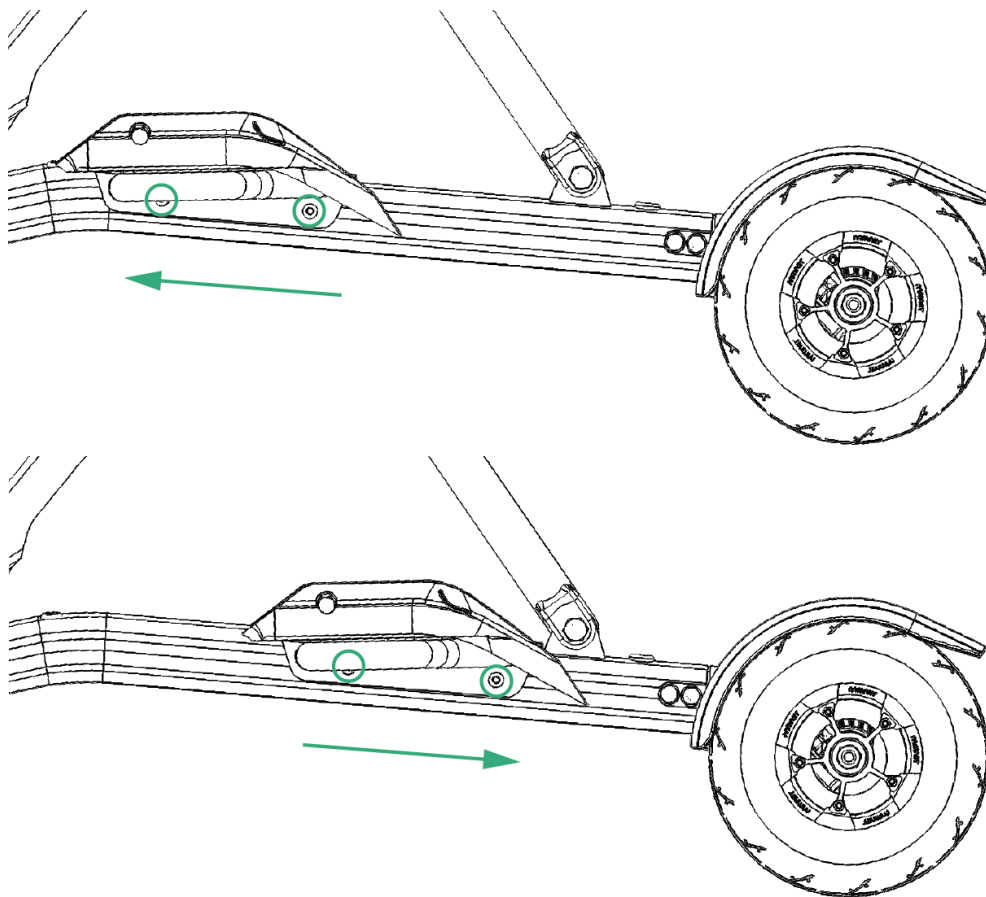

Figure 3.4.7 - Adjusting rear slider

2. **Adjust individual calf supports** by loosening the screw marked with a green circle (hex key **4 mm**), see figure 3.4.8. The screw must not be screwed off completely, just loosened. The calf support can be pushed along the track on the rear slider. This can be done individually for each calf support. This is beneficial for users with differing thigh and calf



lengths. When the calf supports are adjusted to the desired positions, tighten the bolts well.

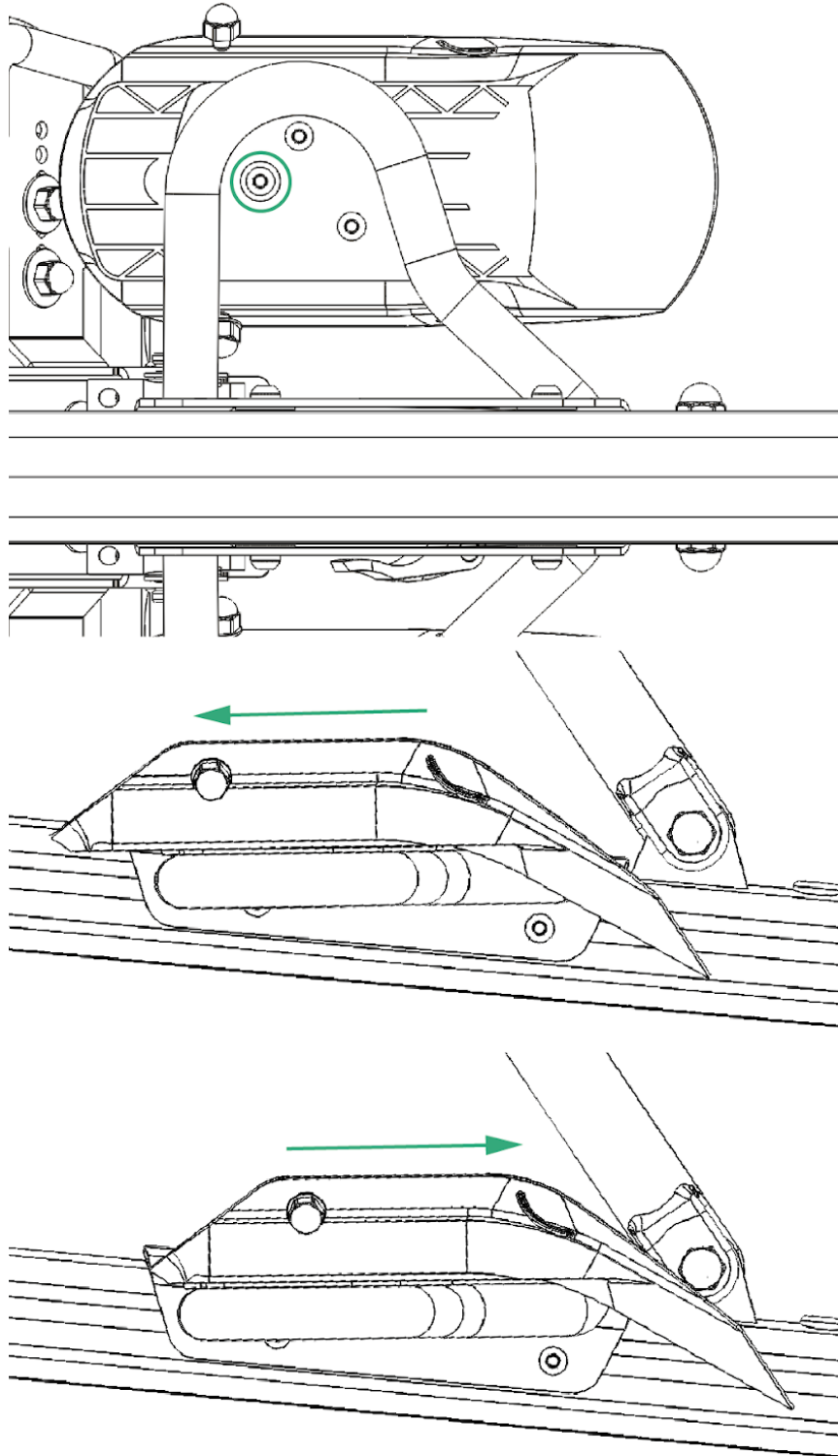

Figure 3.4.8 - Adjusting individual leg support

3.4.1.6 Seat cushion

Spike is delivered with a Togemo vacuum seat cushion, see figure 3.4.9. The cushion is customizable to each individual user. The cushion's surface is made of neoprene, making it waterproof and soft. The cushion is fastened with velcro, making it easy to put it on and remove it. The cushion forms to users rear by the help of vacuum, making it suitable for anyone in need of less pressure or help stabilising.



Figure 3.4.9 - Togemo cushion

Adjusting seat cushion

The cushion's hardness and form is regulated by adjusting the vacuum. Adjustments to the cushion should happen after the seating position has been adjusted accordingly.

1. When adjusting, the seat cushion must be filled with air so the beads in the cushion form to your body. This is done by mounting the adapter to the air spout without attaching the pump and waiting 10-15 seconds so the cushion is loose and malleable, see figure 3.4.10 and figure 3.4.11.



Figure 3.4.10 - Adapter to mount on Togemo-cushion



Figure 3.4.11 - Adapter attached to cushion

2. Remove the adapter and attach the cushion to the seat with the velcro so the air spout is sticking out of the hole in the back of the seat.
3. Sit down in Spike and adjust the cushion to your body. Get assistance from a partner to drain air with the pump so the cushion forms itself around your body, see figure 3.4.12. Remove pump and adapter, and screw the lid on the air spout.



4. Optimal adjustment should make the cushion hard, but formed perfectly after the user's body.
5. The process can be repeated whenever, and is recommended to revisit every season.



Figure 3.4.12 - Pump and adapter mounted for draining air.

3.4.2 Adjusting steering

3.4.2.1 Steering system

The steering system is based on springs, and can be adjusted for different terrains and body control. Two adjustment screws on each side of the steering system regulate this, see figure 3.4.10. The adjustment screws are adjusted with a hex key **4 mm**. By screwing clockwise you increase the spring's resistance. This can be adjusted during your training session to adapt to the terrain and conditions. If the spring load is too tight it can lead to damages on dampers and springs. Instead of applying too much pressure to the damper, you should consider upgrading to a harder damper, see chapter 2.2.1.

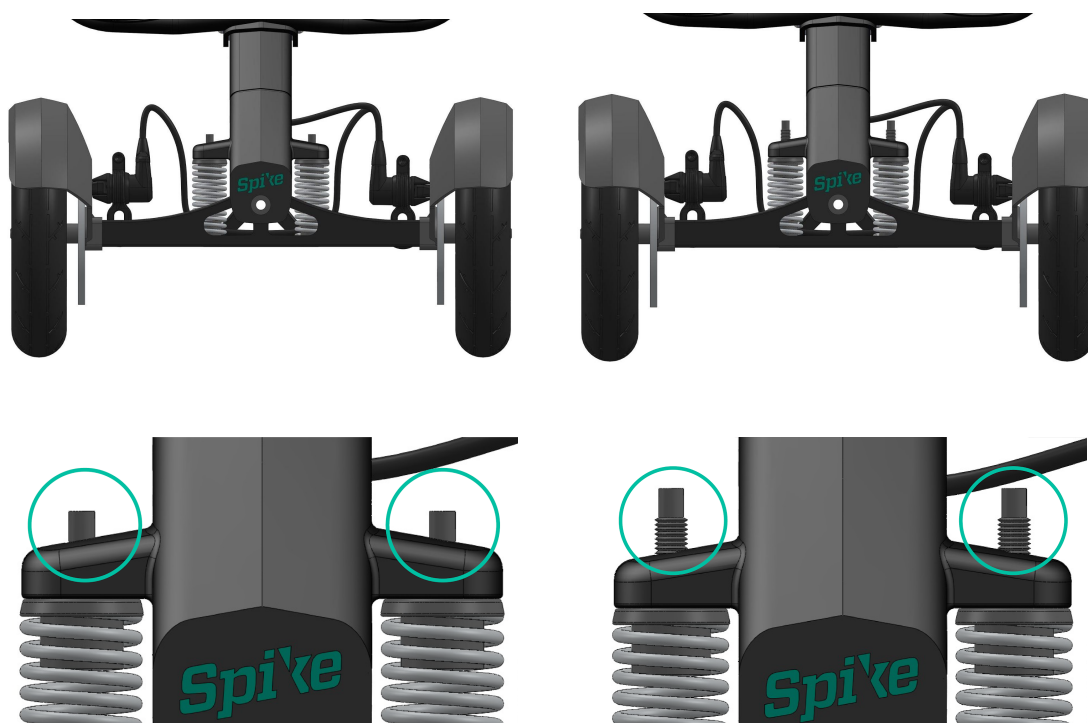

Figure 3.4.10 - Adjustment screws tight (left) and loose (right) position

Adjustment screws can be individually adjusted, making it possible to adapt to users with *asymmetrical weight distribution* or *muscle control*. This is done by tightening the screw on the user's "strong" side and/or loosening the screw on the user's "weak" side, see figure 3.4.10. Adjustment screws must never be completely dismantled, this can lead to the springs detaching.

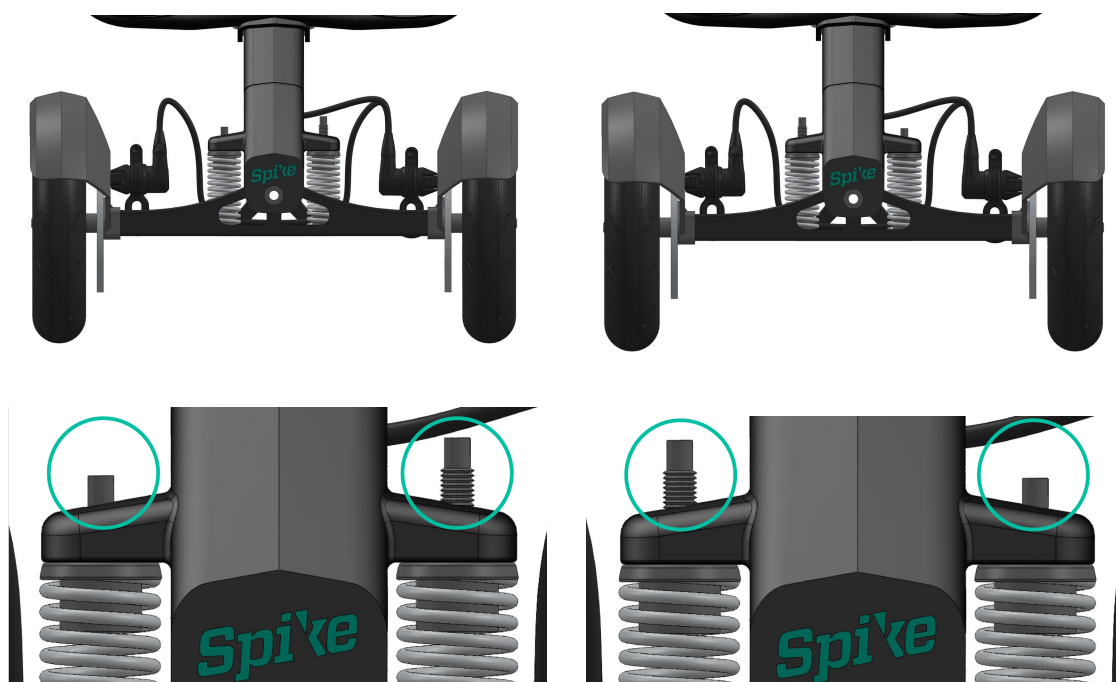

Figure 3.4.10 - Adjustments screws in various positions

3.4.2.2 Wheels

The wheels have tubes and are filled with air in the same way as a bike. The pressure should be max 75 psi / 5,15 Bar. This limit will give the least rolling resistance, making it easier to generate forward propulsion with your poles. Wheels can be taken off the axles by screwing off the axle nut with a wrench **16 mm**.



Important! When assembling the wheels it is vital to adjust the distance between brake pads and brake disk again, see chapter 6.1.2.

3.4.3 Adjusting brakes

See chapter 6.1.2 for adjustments and maintenance of brakes

3.4.4 Adjusting straps



3.4.4.1 Hip strap

The hip strap should be adjusted to the user's *waist* and *stabilising ability* and is fastened to the seat, see figure 3.2.11. The hip strap is fastened by threading each end of the ladder straps to the bindings. The hip strap is tightened and opened as displayed on figure 3.4.12.

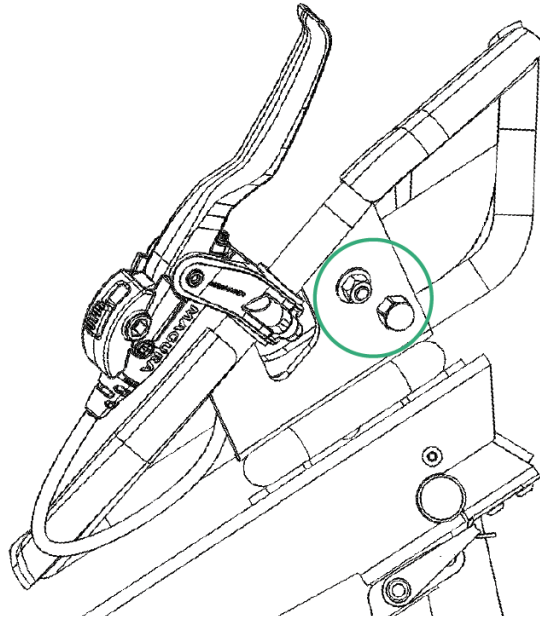

Figure 3.4.11 - Attachment point for hip strap



Figure 3.4.12 - Hip strap in open and closed position



3.4.4.2 Thigh strap

The thigh straps can be fastened in two different ways, either in the knee support or the calf support, see figure 3.4.12. Thigh straps are fastened by threading the ladder straps into the binding, the same way as with a snowboard strap. Thigh straps are opened and closed as displayed in figure 3.4.13.

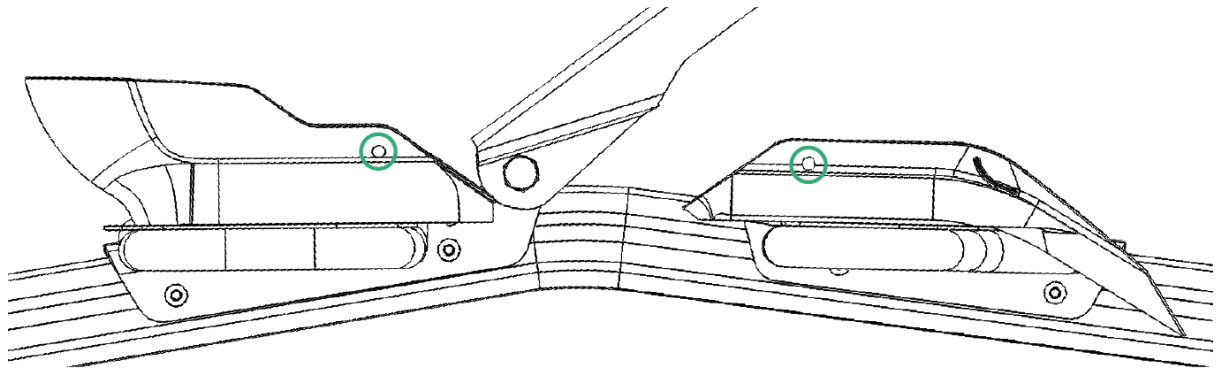

Figure 3.4.12 - Two different attachment points for thigh straps



Figure 3.4.12 - Thigh straps in open and closed position

3.4.4.3 Foot strap

Spike is delivered with foot straps that open and close with velcro. Foot belts can be adjusted to go under the arch of your foot or over your leg to hold your foot in place.





Important! *It can be difficult to put the foot straps on and off alone. Be aware of this if riding alone.*

3.4.5 Adjusting poles

The length of your poles should be adjusted to each individual. A point of reference to start would be to have poles that reach up to your eye-level while seated in Spike. Here it depends on the user's physical heights and lengths.

3.5 Boarding and disembarking

Boarding and disembarking can be a challenge at first. We will therefore walk you through our recommended procedure to reduce risk of dangerous situations, and ensure a quick transition from wheelchair or standing- to Spike- and out again. The consequences of injuries that may occur are considered small, but are still an important part of using Spike. We have listed below options for boarding and disembarking. These are meant as suggestions and each individual can find what best suits them. Disembarkment happens in the opposite order.

3.5.1 Standing position

Place Spike on a flat surface and lock both brakes, see figure 3.5.1. Boarding can be done in several ways depending on the user's preference. The different methods are as follows:

1. Place knee and leg in knee and leg support first before sitting down.
2. Sit down first and hold onto the edge of the seat before placing your legs underneath.

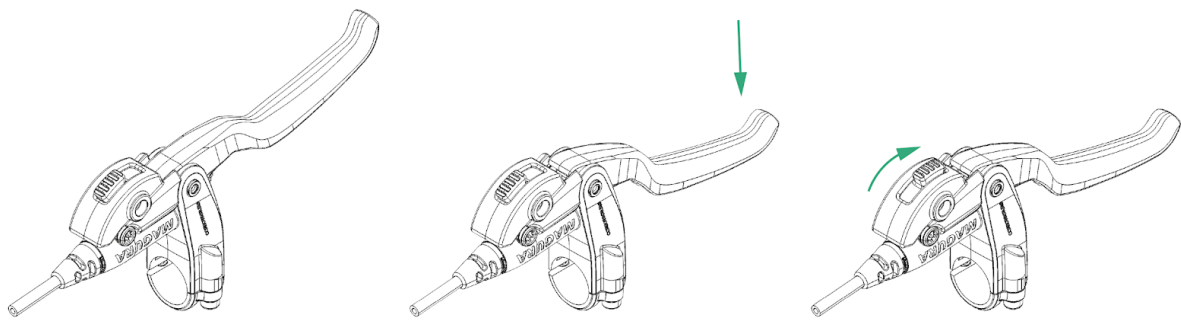

Figure 3.5.1 - How to lock brakes

3.5.2 Wheelchair

Place Spike on a flat surface and lock both brakes, see figure 3.5.1. Park the wheelchair in the same direction next to Spike and lock the brakes. Boarding can be done in several ways depending on the user's preference. A suggestion is as follows:

1. Wheelchair parked on the left side of Spike; Lift your right leg out of the wheelchair and place your knee in the right knee support. Hold onto the edge of the seat and lift your body over to the seating cushion. Lift your left leg and place your knee in the left knee support. Fasten hip and thigh straps.



3.6 Recommended equipment

When using Spike we recommend the following equipment:

- Reflective vest
- Good poles
- Helmet
- Pennant
- Clothes appropriate to conditions
- Water/food on longer rides
- Cellphone
 - When riding alone, we recommend users notify someone on where they depart from and have their cell phone with them to call for help if needed (due to potential poles breaking, flat tires, brake failure etc.)



3.7 Additional equipment

If desired, Spike can be used with additional equipment to increase your use and satisfaction with the product. The following equipment for Spike can be ordered by Exero Technologies as additional:

- Toolkit
 - This kit contains the tools necessary for maintenance and assembly/disassembly of Spike.
- Tires with a rougher surface
 - Rougher tires will increase the rolling resistance, but also increase contact with the hill if you for example wish to use Spike where it can be slippery.
- Backup poles
 - If you unfortunately damage a pole it can be useful to have backups.
- Extra asphalt spikes for poles
 - Over time the ferrules will lose their grip after use on asphalt. Ferrules can be sharpened several times, but should eventually be replaced for better grip.
- Support Handle
 - Some people might have difficulties controlling their core-muscles, especially when leaning their body forward too much. This can lead to the upper body falling forward when in a kneeling position. If this is an issue, Spike can be equipped with a handle for easy gripping when in need to support the weight of the upper body (see figure 3.7.1)
- Spacer Cushion for knees
 - Some people naturally tighten their thigh muscles while seated on Spike. This can lead to the knees pushing toward each other and sitting uncomfortable or falling out of the knee supports. To prevent this, Spike can be equipped with a spacer cushion that keeps the thighs and knees separated (see figure 3.7.2). The



cushion can be delivered in many different sizes, and even be special made (See figure 3.7.3).

For price offers contact Exero Technologies: hello@exerotech.com

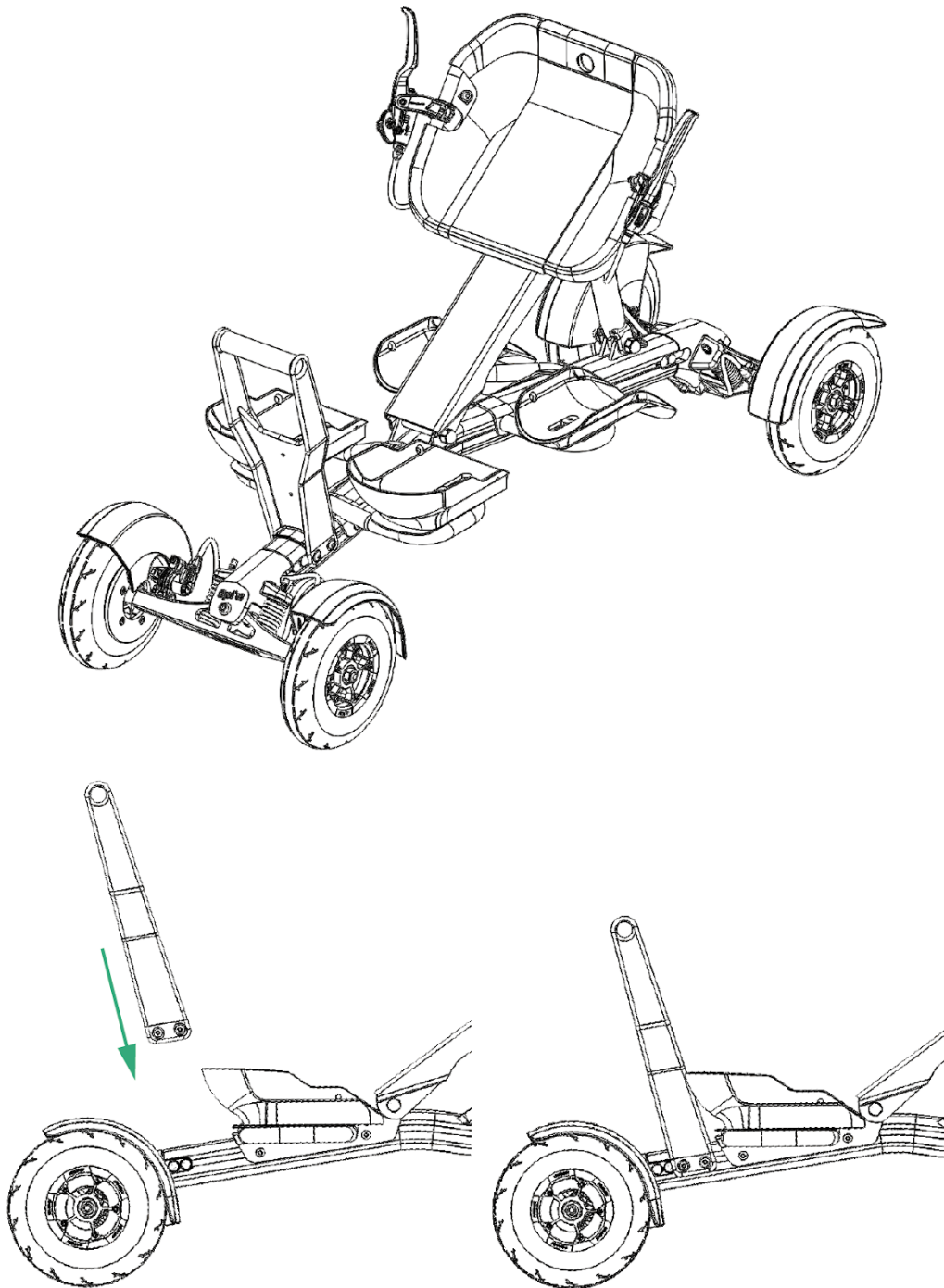

Figure 3.7.1 - Additional Equipment: Support Handle

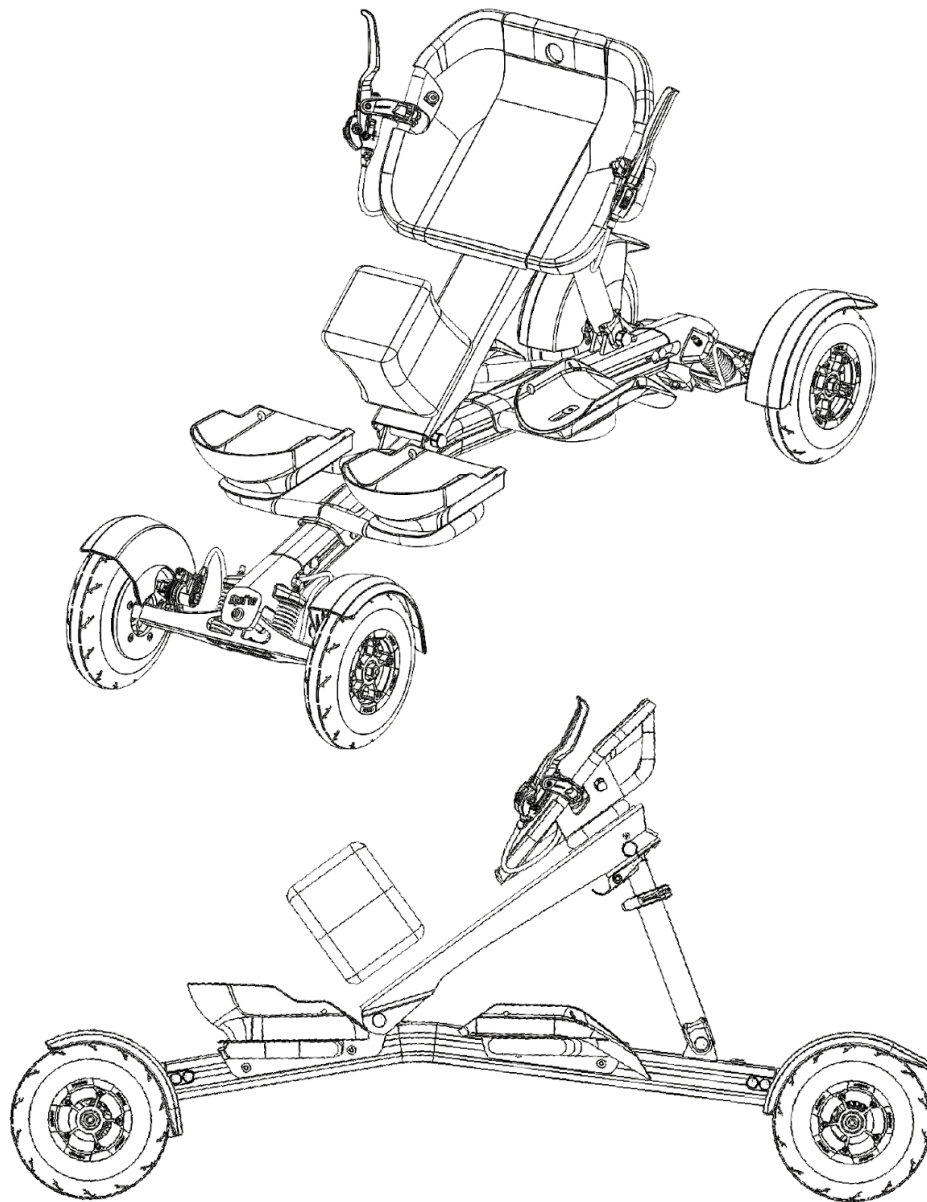

Figure 3.7.2 - Additional Equipment: Spacer Cushion positioned on Spike

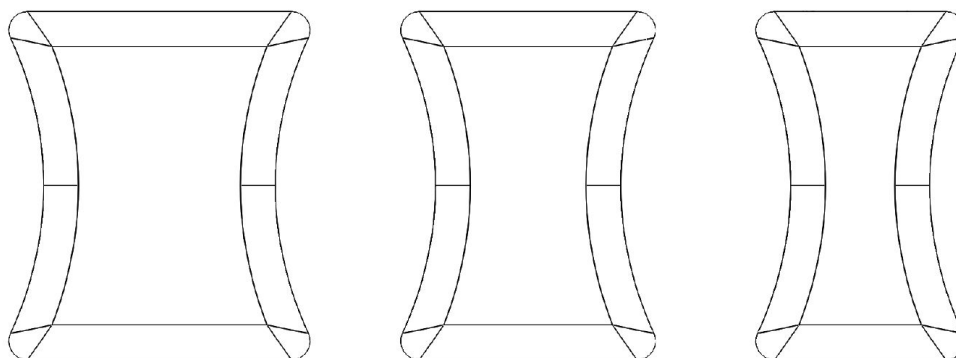

Figure 3.7.3 - Additional Equipment: Three examples of Spacer Cushion sizes



4 CHECKLIST BEFORE EACH USE



4.1 Checking nuts and bolts

4.1.1 Wheel nuts

Inspect the nuts of the axle on each of the four wheels, see figure 4.1.1. These must be tightened to where the wheel still freely rotates. Too hard tightening will affect the rolling resistance. Use a **16 mm** wrench.



Figure 4.1.1 - Tightening wheels

4.1.2 Nuts and bolts for steering

Inspect the screws, nuts and bolts on each truck (steering mechanism), see figure 4.1.2. These must be extensively tightened so the nuts don't fall off. Use a **10 mm** wrench and a **5 mm** hex key.



Figure 4.1.2 - Tightening steering system

4.1.3 Nuts and bolts for seat arm and seat post

Before tightening these bolts you must remove the protection cap. Inspect the screws and nuts on the seat arm and seat post. Use a **13 mm** wrench and adjustable wrench and tighten, see figure 4.1.3. Re-place protection cap.



Figure 4.1.3 - Tightening seat arm (right) and seat post (left)

4.1.4 Screws for front slider

Inspect the four screws on the front slider, two on each side, see figure 4.1.4. These should be extensively tightened so the sliders don't move on the mainframe. Use a hex key **4 mm**.

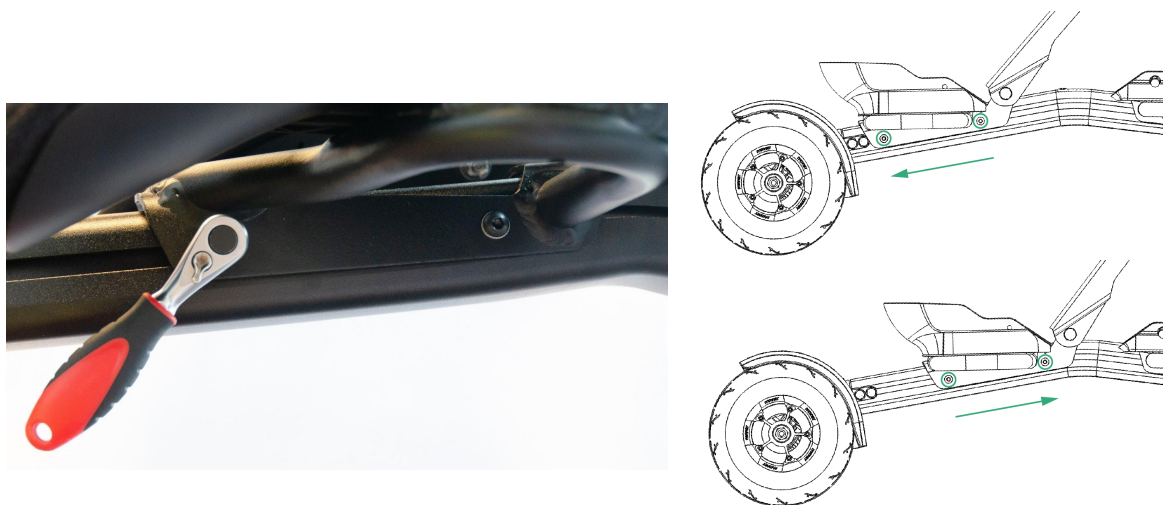

Figure 4.1.4 - Tightening front slider



4.2 Checking brakes

Execute a function test of the brakes before use. This is done by squeezing each brake handle and pushing Spike simultaneously. The brakes should restrain so the wheels do not rotate. If the wheels rotate you must undergo appropriate maintenance before you can use Spike. Brake maintenance is described in chapter 6.1.2.



4.3 Checking straps and strapping

Before use, the user must ensure that the straps are fastened properly to Spike. Control that there is no damage to the straps and that they open/close as they should.



4.4 Checking air pressure

Control tire pressure before use. Pressure should be max **75 psi / 5,15 bar** and min **40 psi / 2,75 bar**. Too low pressure in the tires will increase the rolling



resistance making your experience more tiring. Low pressure tires also increases the chance of puncturing.



4.5 Checking steering system

Control that the steering system is correctly set before each use. Make sure adjustment screws are in place. Adjust the steering system to the intended session. Adjusting your steering system is described in chapter *3.3.2 Adjusting steering*.



5 GET THE MOST OUT OF YOUR SPIKE

Through developing Spike, we've met many people with great ideas and thoughts on how Spike can be used in as many ways as possible. Alongside our own experience, we wish to share some advice so you can get the absolute most out of your Spike.

5.1 - Seat angle

By adjusting the seat angle, your use of Spike can change. This gives variations in the pressure put on your knees and rear, while engaging different muscles.

Forward-leaning seated position

A forward-leaning seated position will increase the pressure put on your knees and reduce the pressure on your rear, see figure 5.1.1. This is considered an *aggressive* seated position and will make it easier to utilize more of your upper body in every stride. Such a position can be demanding to maintain over time, but the user will gain more speed and more response when steering.

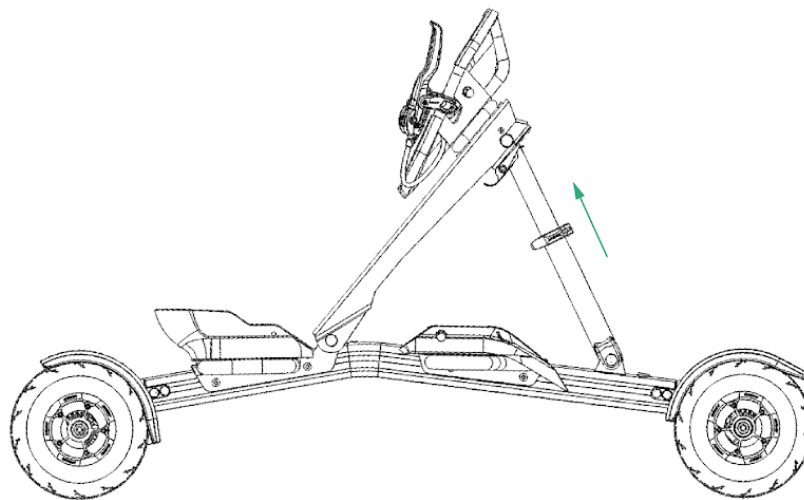

Figure 5.1.1 - Forward-leaning seated position

Backward-leaning seated position

Placing the seat further down will give the user a more backwards-leaning seated position that puts more pressure on your rear and less pressure on your knees, see figure 5.1.2. This may for some make it easier to sit in Spike over longer periods of time and can be useful for long distance rides at a lower



tempo. For some this may feel heavier, as less of the upper body is active in this position, but simultaneously more stable than in the forward-leaning position, as your weight is distributed more equally between your knees and rear.

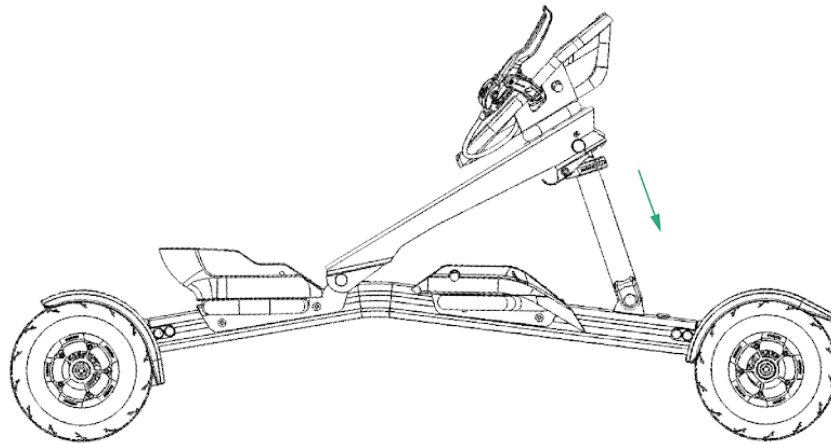

Figure 5.1.2 - Backward-leaning seated position

5.2 - Adjusting steering setting

Adjusting steering settings means that the user can customize Spike's springs to fit their needs, for example between low speeds and good swing radius, or higher speeds and more stability.



Important! Read chapter 2.2.1 Especially important - Speed wobbles in the steering system before you start adjusting the steering settings.

For the most part the steering system can be adjusted gradually between a soft and hard setting on the springs (see figure 5.2.1, something the user can adjust for different uses:

- A soft setting will make it easier to lean from side to side with Spike. This reduces the swing radius and is best suited for low speeds and a lot of turning, for example on small city roads.



- A hard setting will demand more weight and power to lean from side to side. This increases the swing radius and stability in higher speeds. This is best suited for users who desire more speed, especially on straight stretches with few turns. A hard setting will make it easier to get optimal power with each stride of your pole, and creates more effective propulsion.
- A natural progression would be that beginners start with a soft setting before gradually tightening the springs for higher speeds and more efficient use of energy per stride.

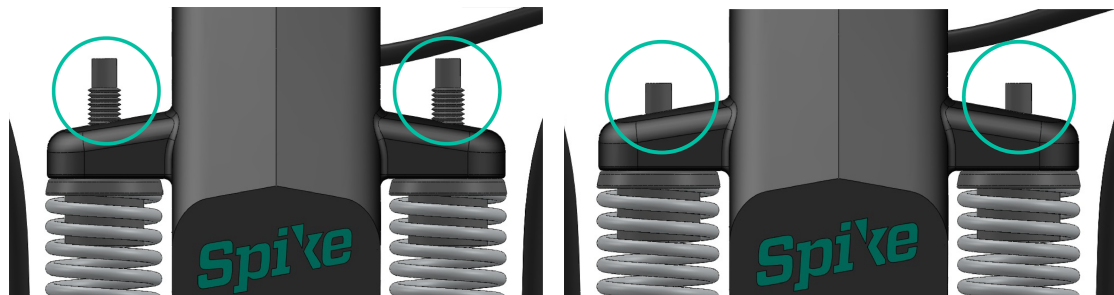

Figure 5.2.1 - Adjustment screws tight (left) and loose (right) position

5.3 - Adjusting pole lengths

For those who desire further variations in their training, adjusting the length of your poles can be useful. As previously mentioned, we recommend having poles that reach up to your eye-level while seated in Spike. By using slightly shorter poles (5-10cm) the user can have a slightly higher frequency which can for example be useful when poling a lot uphill. We recommend experimenting to find the most fun and dynamic training.

5.4 - Drain tire air for higher resistance

This is a tip for those who have mastered using Spike and have good physical capability. For those who wish to use Spike as training equipment, it can be useful to increase the rolling resistance. This is to recreate the resistance you receive from the friction between snow and cross-country skis. The same goes for those looking for heavy interval training without access to hills.

- 1) Screw off the “cap/hood” of the wheel’s airspout.



- 2) Use a screwdriver or key and gently press down on the spout.
- 3) You will now hear the sound of air being released from the hose.
- 4) Drain only **a little** air, you won't need to release much for the resistance to increase exponentially.
- 5) If you have access to a pump that displays the air pressure, the recommended minimum is 40 psi / 2,75 bar.
- 6) Screw the "cap/hood" back on
- 7) Repeat on all four wheels

Remember to refill air so that Spike is ready for your next session.



Important! *Make sure to not release too much air as this can increase the chances of puncturing your tire. The minimum should be 40 psi / 2,75 bar.*

5.5 - Terrain variations

Spike is designed to be used on different terrains. The easiest is to use Spike on asphalt where it will roll easier due to less surface resistance. For beginners this will be the natural starting point for mastering Spike. But for increased enjoyment and variation, we encourage you to use Spike on other terrain such as gravel and trail. The rolling resistance here will be more than on asphalt. Uphill will therefore be heavier than on asphalt.



6 STORAGE AND MAINTENANCE

To ensure the lifetime of your Spike, it's important to sufficiently take care of the product. Maintenance specified in the user manual must be followed. The user can maintain Spike themselves with the exception of what is listed under **authorised maintenance**. Authorised maintenance of the product must only be done by Exero Technologies or partners approved by Exero Technologies as this reduces risk of faulty assembly. Exero Technologies recommends that Spike undergoes maintenance at least once a year by Exero Technologies or people authorised by Exero Technologies to ensure the product is intact and to extend its lifespan.

6.1 Self maintenance

After use Spike should be washed with a damp cloth. Here is how to care for the different parts:

- 1) Remove seat cushion, knee pads and leg support and wash separately.
- 2) All other parts should be washed with a damp cloth and mild detergent.
- 3) Dry with a towel after wash.
- 4) Lubricate all movable parts with a thin oil:
 - a) Steering system
 - b) Screws for seating adjustment



Important! *DO NOT lubricate brake discs and brake pads with oil, this will significantly reduce braking capabilities.*



Be cautious of salt water. Do not use solvents, steel brushes or pressure washers. This can shorten the lifespan of the product.



Inspection

We recommend regularly inspecting Spike. In table 6.1 you will find an overview of how you can take of your Spike.

Component	Function and inspection	before use	Every quarter
Tires	Check for damages to the tires	x	
	Check air pressure (chap 4.4)	x	
Wheels	Check that the wheel rotates freely	x	
	Check that the wheel nuts are fastened well	x	
	Check bearings (see chap 6.1.1)		x
Brakes	Check that the brakes work	x	
	Check brake hoses for leaks	x	
	Check brake pads		x
Steering system	Check that there are no foreign materials in the springs and that the springs move freely	x	
	Check that all four screws are properly installed (see figure 3.3.2)	x	
Cushion cover	Check the cushion cover for damages	x	
Screws and nuts	Check screws and nuts in relation to chapter 4.1	x	
Seat, knee support and leg support	Check that the seat, knee support and leg support are all properly fixed and without damage	x	
	Check that clamps under the seat are correctly closed	x	
	Check for cracks in the plastic material (seat, knee support, leg support)		x



Table 6.1 - Maintenance



Troubleshooting

If you spot errors with your Spike, table 6.2 may be of use.

Error	Solution	Reference
Creaking sounds	Lubricate movable parts with a thin oil	
Wheels do not rotate	Nuts may be too tight. Loosen the nuts and tighten with less force. Inspect the bearings, they may be broken. Check that the brake pads are correctly distanced from the brake discs.	Chap 6.1.1 Chap 6.1.2
Poor braking ability	Check that the brake pads are correctly distanced from the brake discs.	Chap 6.1.2
Spike seems heavier when poling.	Check if the handbrake is on. Check that the wheels have sufficient air. Check that the brake pads are correctly distanced from the brake discs.	Chap 4.4 Chap 6.1.2
Seat cushion is losing its shape	Re-adjust the cushion	Chap 3.3.1

Table 6.2 - Troubleshooting



Important! Contact Exero Technologies if you cannot solve the problem or discover flaws in the product.



6.1.1 Bearing maintenance

The wheels rotate around the axle by the help of two bearings per wheels, see figure 6.1. These bearings should be lubricated regularly with a thin oil to prolong lifespan. If your bearing is worn or the beads have fallen out, you must replace the bearing.

To check the state of your bearings do the following test:

1. Take the bearing out of the rim
2. Hold the inside of the bearing whilst rotating the outside
 - a. If the bearing rotates freely without noise, it is all set
 - b. If the bearing rotates poorly or makes noises, it needs maintenance or replacement with a new one.
3. Eventual maintenance would be removing dirt and grime to then lubricate with a thin oil. Repeat this until the bearings rotate smoothly.

If maintenance does not work, the bearing must be replaced. Contact Exero Technologies for more information or purchase of new bearings.



Figure 6.1 - Bearing

6.1.2 Axle maintenance

The axles must be washed and lubricated with a thin oil regularly to avoid corrosion. This is done by disassembling screens, wheels and spacers that sit on the axles. First clean with water and soap before lubricating with a thin oil.



6.1.3 Brake maintenance

Spike has hydraulic brakes, similar to those used on mountain bikes, and are filled with hydraulic oil. If you notice a leak in the hose, the oil must be changed and the hoses and connecting hoses must be inspected. Causes of leaks may be holes in the hoses or connectors that have come loose.

Brake handles

Brake handles are located on each side of the seat. The handles can be adjusted for sensitivity by using a Torx 25 underneath the brake handle. By turning the screw clockwise, the brake pads will be pushed closer to the discs, increasing the brake sensitivity. Squeeze the brakes once to notice the changes while adjusting, so the system is calibrated.

Brake pads

Brake pads can be adjusted by loosening the screw underneath, see figure 6.2. Ideally the distance between brake pads and discs should be 2-3 mm, as shown on the green image in figure 6.2. Too much distance will reduce the braking effects and if the brake pads are too close it can increase Spike's rolling resistance.

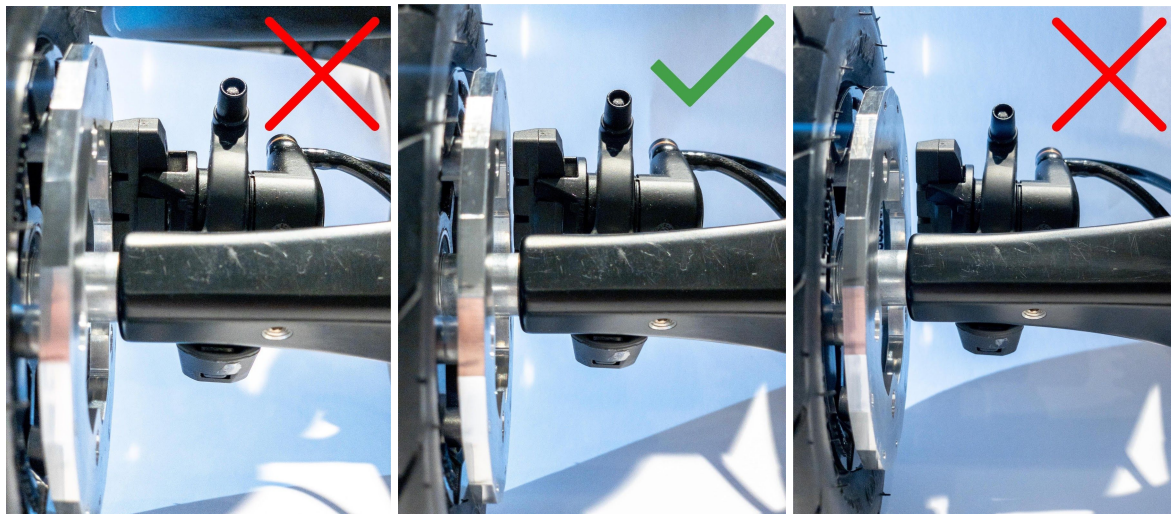

Figure 6.2 - Correct and incorrect distance between brake pads and discs



Important! This screw must not be screwed when adjusting brakes, see figure 6.3.



This can lead to leaking brake fluids.



Figure 6.3 - NOTE! Do not adjust this screw. Adjustment of this screw may lead to leakage

6.1.4 Cushion maintenance

Seat cushion

1. Control regularly the cushion's condition
2. Screw on the air cap before cleaning
3. Standard washing detergent can be used, unless acid based
4. All standard disinfectants can be used
5. Can be washed in a washing machine on max 60°C
6. Hang dry

NOTE! Do not put in dryer

Additional cushions

1. Remove cushion cases and wash separately
2. Standard washing detergent can be used, unless acid based
3. All standard disinfectants can be used
4. Can be washed in a washing machine on max 60°C
5. Hang dry

NOTE! Do not put in dryer

6.1.5 Flat tires

When running a flat tire or when changing tires follow these steps:

1. Remove the wheel from the axle
2. Drain all air from hose



3. Remove rim by loosening the 5 screws at the edge of the rim
4. The rim splits into two parts, removed from each side of the tire
5. Remove hose and replace
6. Reinstall the rim in the same way it was removed
7. Fill air (30-50 psi / 2,0 - 3,5 Bar)
8. Install the wheel on the axle

6.1.6 Maintenance of mudguards

1. Do not store the mudguards in a hot car for a long time.
2. Do not expose the mudguards to forces during transport and storage (eg by placing luggage or other things on top of the Spike so that the mudguards remain pinched).
3. Place something (eg paper, foam rubber or similar) between the mudguard and the wheels to keep the shape during transport and storage. See Figure 6.4:



Figure 6.4 - Illustration of maintenance of mudguards during transport and storage

If one or more mudguards are damaged, they can be replaced using the supplied sleeves in your utility bag. A step-by-step video can be found on our YouTube channel, and the video is called "How to disassemble wheels and mudguards on Spike". You can find it via this link:

<https://www.youtube.com/watch?v=NR-MDAPzqU8>



6.2 Authorised maintenance



Maintenance or repairs described in this chapter must not be handled by the user, unless approved by Exero Technologies. This type of maintenance must be handled by people approved by Exero Technologies. If such maintenance is required we ask the owner of the product to contact Exero Technologies for procedure.

6.2.1 Damaged parts



If you find cracked or worn parts on Spike, or parts that no longer function as intended, contact Exero Technologies for maintenance or repair.

6.2.2 Steering maintenance



We recommend regularly giving the steering system a full service. This requires a specialist and must be done by authorised personnel. Contact Exero Technologies for more information.

6.3 Storage and transport

Spike should be stored in a dry environment avoiding direct sunlight, either indoors, in a garage or shed when not in use. Ensure that Spike is clean and dry before storing. The brakes will not handle temperatures lower than -15 degrees and higher than 55 degrees celsius, and pressure washing is prohibited on the entire product,

Spike can be compacted, something very practical for storage and transport, see chapter 6.4. When compacting Spike the provided strap must be attached, see figure 6.4. The strap must be attached around the seat arm and mainframe so it's positioned well under transport. This is to avoid trapping fingers and unnecessary wear on the product.



Figure 6.4 - Strap for transport

Under transport we recommend padding or disassembling asphalt spikes to reduce the risk of an accident. Spike should be padded with bubble wrap or protected with similar packaging under transport, especially when being shipped.



6.4 Disassembly and reassembly

Disassembly

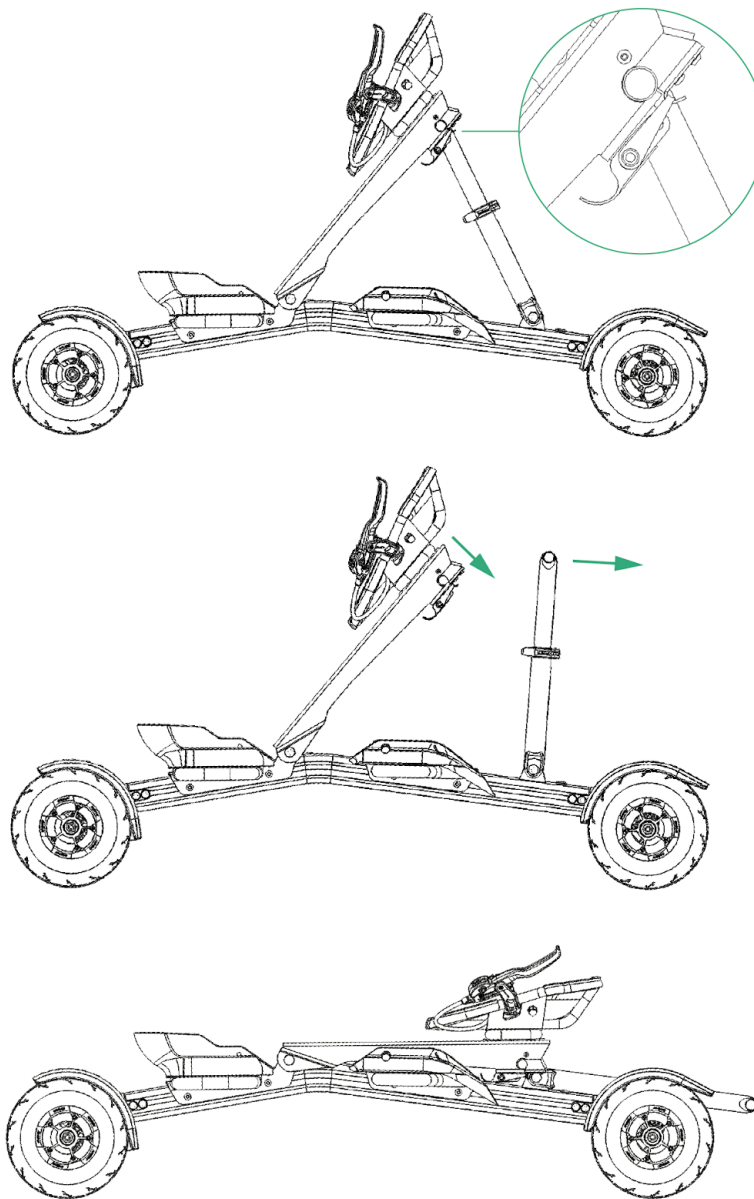

Figure 6.4.1 - Compacting Spike

1. To compact Spike, loosed the two locks under the seat.
2. Push the seat post out of its track and place it along the mainframe.
3. Then place the seat arm down by the mainframe.
4. Attach the strap around the mainframe and seat arm so it's held together.
5. To save more space you can disassemble the wheels, but this is recommended only when necessary. Usually it will require adjusting brakes and wheels again when re-assembling.



Important! Be aware of trapping fingers when disassembling



Figure 6.4.1 - Danger of trapping fingers during folding.

Re-assembly

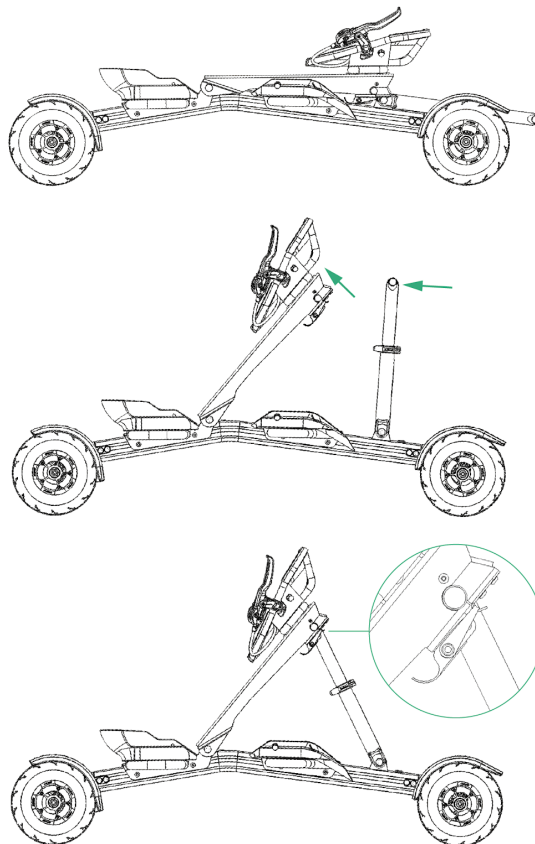

Figure 6.4.2 - Re-assembly of Spike



1. To re-assemble Spike, loosen the seat strap and lift up the seat post.
2. Push the seat post back into its track underneath the seat and use locks.
3. The seat angle is adjusted by regulating the length of the seat post by using the seat post clamp, see figure 6.4.3.
4. Make sure all screws and locks are correctly installed before starting your next ride.



Figure 6.4.3 - Seat post clamp



Important! Follow the points in chapter 4 after assembly to ensure the product is ready for use.



Assembly instructions for accessories

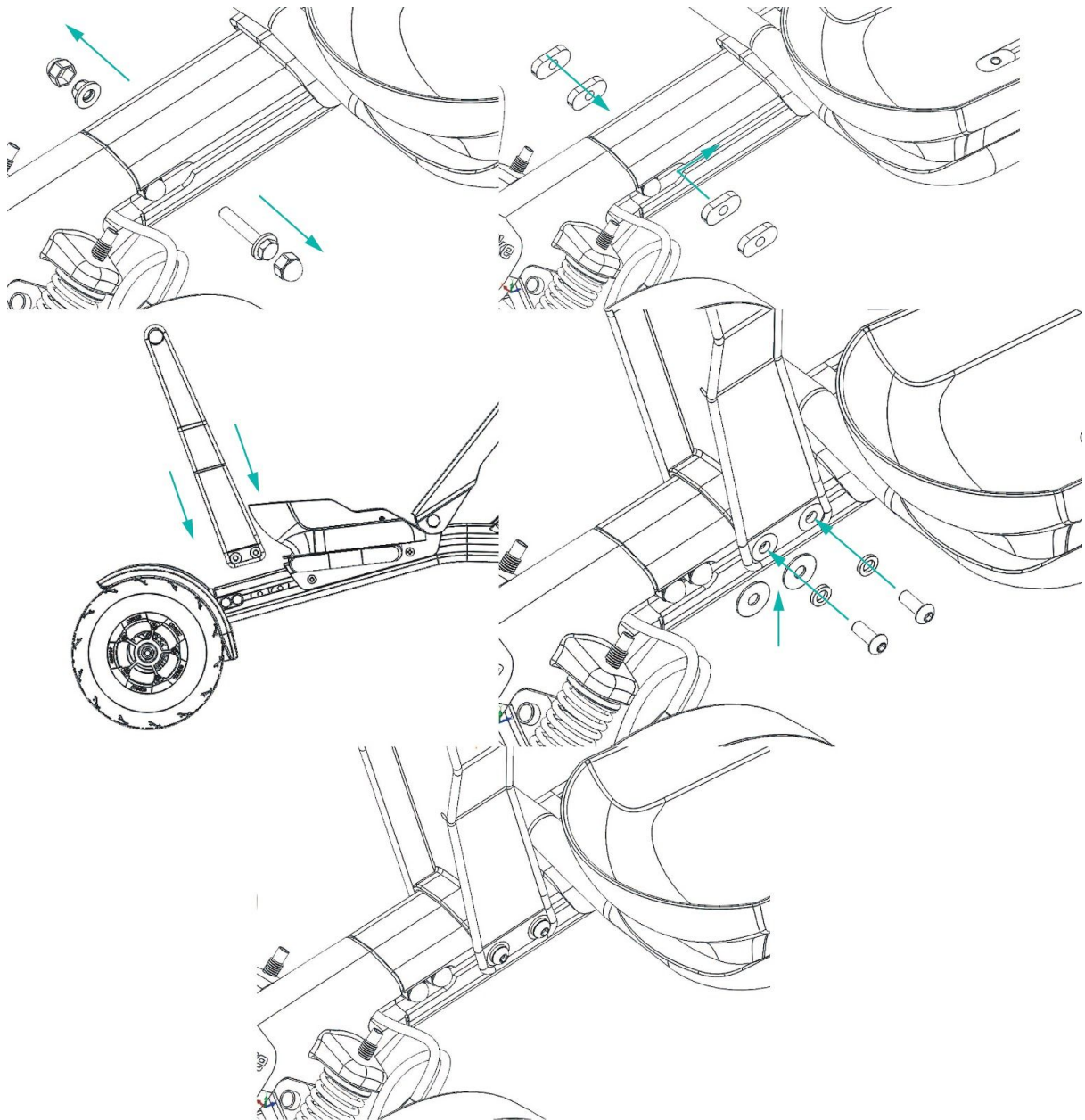



7 WASTE MANAGEMENT

7.2 Waste management

List of Spike parts and recommended disposal procedures.

Figure 1.1 in ch 1.3 shows images of parts.

Part	Component	Material	Recommended disposal
Wheel	Tire	Rubber	Waste
	Hubcap	Plastic	Waste
	Spokes	Aluminum	Metal
	Hose	Rubber	Waste
Screens		Plastic	Waste
Mainframe		Aluminum	Metal
Slider		Aluminum	Metal
Seat arm		Aluminum	Metal
Seat post		Aluminum	Metal
Seat		Aluminum	Metal
Knee support		Plastic	Waste
Leg support		Plastic	Waste
Straps		Textile + plastic	Waste
Steering system with brakes	Brake hose	Rubber	Waste
	Brake fluid	Hydraulic oil	Brake fluid is filled into its own container. Delivered as hazardous waste.
	Handle	Plastic	Waste
	Springs	Metal	Metal



Cushions		Textile	Waste
Nuts and bolts		Metal	Metal
Nut caps		Rubber	Waste

Notes:

