



Supra platform lift

Installation Manual

INS-TP14-EN-02

ThyssenKrupp Encasa



ThyssenKrupp

Manufacturer:

ThyssenKrupp Encasa srl
Via S. Cannizzaro, 2 - 56121 Pisa - Italy
E-mail: info@encasa.it
Website: www.encasa.it

Model:

SUPRA (product configurator from TP14)

Date of publication:

Rev 02 – 10/2015

Rev.	Date	#	Page
02	10/2015	INS-SUP-17 : Warning!. INS-SUP-22 : Fig. Stage 5 / Stage 11. DESC/OP E-SUP-10 : Warning!.	53 62 124

1. GENERAL INFORMATION.....	5
1.1. ADDRESSEES	5
1.2. SUPPLY AND PRESERVATION	5
1.3. UPDATES	5
1.4. LANGUAGE.....	6
1.5. OPERATORS	6
1.6. SYMBOLS USED IN THE MANUAL	7
1.7. PERSONAL PROTECTIVE EQUIPMENT	7
1.8. EQUIPMENT	8
1.9. INSTALLATION KIT	12
1.10. TIGHTENING TORQUES.....	13
1.11. WARNING SIGNS	13
1.12. SHIPPING CONFIGURATION.....	14
2. DESCRIPTION OF THE MACHINE	16
2.1. COMPONENTS LIST	16
3. ASSEMBLY OF THE MACHINE	18
3.1. MACHINE ASSEMBLY PROCEDURE	18
3.2. PROCEDURES FOR FINAL CHECKS.....	68
4. MECHANICAL ADJUSTMENTS.....	79
5. ELECTRICAL/ELECTRONIC ADJUSTMENTS	89
5.1. ELECTRICAL/ELECTRONIC ADJUSTMENT PROCEDURES.....	89
5.2. DESCRIPTION/OPERATION OF THE ELECTRICAL/ELECTRONIC DEVICES.....	109

[PAGE INTENTIONALLY LEFT BLANK]

1. GENERAL INFORMATION

1.1. ADDRESSEES

The manual is intended for specialised operators in charge of installing the lift at the customer's premises. The topics herein regard the correct installation procedure of the machine. This will put the operator in condition to install it in full safety and without encountering any technical problems.

The installer is responsible to keep this documentation intact and to allow it to be consulted at any time when needed.

1.2. SUPPLY AND PRESERVATION

The manual is supplied in **paper and electronic** format. All additional documentation (wiring diagrams, sub-supplier manuals) is supplied in an annex to this manual.

Keep this manual with the machine so it can be easily consulted by the installer.

The manual (and all of its annexes) is an integral part regarding safety, therefore:

- **it must be kept intact** (in all its parts). Should it be lost or damaged, it is necessary to immediately ask for a new copy;
- **It must accompany the machine until its demolition** (even if moved, sold, leased, rented, etc.)

The attached manuals are an integral part of this documentation and the same recommendations/prescriptions of this manual apply.

1.3. UPDATES

Should the machine require functional modifications or replacements, the machine manufacturer is responsible for revising or updating the manual. The manufacturer is responsible for delivering the manual update.

The user is also responsible for ensuring that, should this document be modified by the manufacturer, only the updated manual versions are effectively present in the points of use.

1.4. LANGUAGE

The original manual was written in **Italian**.

Any translations in other languages must be made starting from the original instructions.

The Manufacturer considers itself responsible for the information in the original instructions. Translations in other languages cannot be fully verified. Therefore, in case of a detected inconsistency, respect the text in the original language or contact our Technical Documentation Department.



1.5. OPERATORS

In order to establish the competencies and qualifications of the operators in charge of the various tasks (start-up, cleaning, routine maintenance) with certainty, consult the following table:

QUALIFICATION	DEFINITION
Installer/mechanical maintenance engineer	<p>Qualified installer technician capable of repairing and installing the machine.</p> <p>Qualified installer technician capable of:</p> <ul style="list-style-type: none"> ▪ having access to all parts of the machine for a visual analysis ▪ checking the conditions of the equipment ▪ adjustments or calibrations or of intervening on mechanical parts for adjustments ▪ maintenance and repairs ▪ reading pneumatic and hydraulic diagrams, technical drawings and spare parts lists. ▪ operating the machine with downgraded safety devices <p>Note: he/she is not qualified to work on live electrical systems.</p>
Electrical installer/maintenance engineer	<p>Qualified installer technician capable of installing, connecting and wiring all the electric parts of the machine.</p> <p>Qualified installer technician capable of:</p> <ul style="list-style-type: none"> ▪ working on the adjustments and on the electrical systems for maintenance and repairs ▪ replacing worn parts; ▪ reading wiring diagrams and checking the proper functional cycle ▪ He/she can work while the electrical circuits in the electrical panel, junction boxes, control appliances, etc. are live only if suitably qualified (PEI). <p>(See standard EN50110-1).</p>

1.6. SYMBOLS USED IN THE MANUAL







The following is a list of the symbols used in this manual:

SYMBOL	DESCRIPTION
	GENERIC HAZARD
	DANGEROUS ELECTRICAL VOLTAGE
	IMPORTANT INFORMATION. SUGGESTIONS FOR OPTIMAL WORK PROCEDURES.

1.7. PERSONAL PROTECTIVE EQUIPMENT

In order to protect the personal integrity of the machine installer, it is **mandatory to use the personal protective equipment highlighted on each sheet** describing the installation phase. It must be in good conditions and working order, as required by relevant legal standards.

The following is a list of the PPE required during the installation phases:

SYMBOL	DESCRIPTION
	HELMET
	PROTECTIVE GOGGLES
	SAFETY SHOES
	GLOVES
	HEARING PROTECTION
	FALL ARRESTER SAFETY BELTS











**CAUTION!**











For each installation step, there will be icons highlighting the protective equipment required, considering the minimum safety level necessary to correctly and safely perform the activities described. These requirements must be integrated with standards in force regarding safety at work and pertinent to the country where the machine is installed, as well as with any further improvements resulting from experience and good practice techniques.





1.8. EQUIPMENT

The following is a list of the **recommended equipment** for installation of the lift and relative rail:

RECOMMENDED TOOL	IMAGE
COMBINATION SPANNERS: <ul style="list-style-type: none"> ▪ 1 spanner 8mm ▪ 2 spanners 10mm ▪ 2 spanners 13mm ▪ 1 spanner 17mm ▪ 1 spanner 19mm ▪ 1 spanner 20mm ▪ 1 spanner 21mm ▪ 2 spanners 24mm 	
10, 13MM SOCKET WRENCH	
FLAT-HEAD SCREWDRIVERS: <ul style="list-style-type: none"> ▪ 0.5 x 3 x 75 ▪ 0.8 x 4 x 125 	
PHILLIPS SCREWDRIVERS: <ul style="list-style-type: none"> ▪ PH1 x 80 ▪ PH2 x 100 ▪ PH3 x 200 	
NOSE PLIERS	
HAMMER	

PLASTIC MALLET	
CUTTER	
3M TAPE MEASURE	
CAULKING GUN	
TESTER	
MARKER	
STANDARD LEVEL	
GONIOMETER WITH SPIRIT LEVEL	
FLAT IRON FILE 5 x 10 x 150	
HAMMER DRILL	
MASONRY BITS DIAMETER 6 – 8 – 12 – 14	

<p>IRON BITS DIAMETER 3 – 4 – 6 – 6,5 – 6,75 – 8 – 8,5 – 10</p>	
<p>ALLEN WRENCH DIAMETER 4 – 5 – 6 – 8</p>	
<p>COUNTERSUNK BIT</p>	
<p>SOFT BRUSH</p>	
<p>RAG</p>	
<p>CUTTING OIL SPRAY CAN</p>	
<p>HAND SAW</p>	
<p>JIG SAW WITH BLADE FOR CUTTING PLASTIC</p>	
<p>HOOK WRENCH WITH SQUARE PIN FOR RING NUTS (25MM)</p>	
<p>SOCKET WRENCH + 13MM RATCHET</p>	

<p>T-WRENCH + 13MM SOCKET</p>	
<p>PLUNGER PUMP</p>	
<p>SPRING DYNAMOMETER</p>	
<p>PORTABLE LAMP</p>	
<p>TAPE FOR CLOSING OFF WORKSITE</p>	

1.9. INSTALLATION KIT

An **installation kit** is provided by the manufacturer, or owned by the installer himself, for quick and efficient installation.

The kit includes the following special equipment:

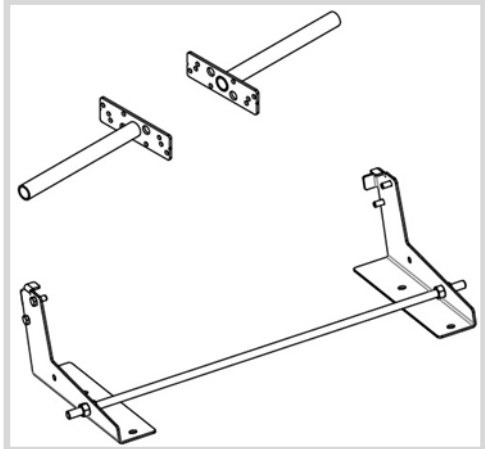
COMPONENT DESCRIPTION	IMAGE
HANDLES FOR LIFTING TRACTION UNIT	
SUPPLEMENTARY SELF-BEARING SUPPORT	



IMPORTANT!
Without these components it is not possible to install the machine.

1.10. TIGHTENING TORQUES

To guarantee correct assembly of the machine, the bolts must be clamped with appropriate **tightening parts** as carried in the following table.



SCREW DIAMETER [mm]	TIGHTENING TORQUE [Nm]	SCREW DIAMETER [mm]	TIGHTENING TORQUE [Nm]
M5	6	M14	136
M6	10	M16	210
M8	25	M18	290
M10	49	M20	410
M12	86	M22	550

Note: the tightening torques not necessary to install the system are grey.

1.11. WARNING SIGNS

Easy to understand warning signs quickly call the attention to objects and situations which can cause certain dangers.

The signs do not take the place of safety measures, but only recall them.

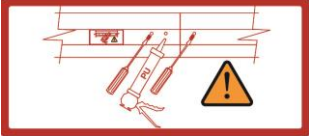
SYMBOL	DESCRIPTION
	GENERIC HAZARD
	DANGEROUS ELECTRICAL VOLTAGE
	DANGER OF TRIPPING
	<ul style="list-style-type: none"> ▪ POLYURETHANE INSERTION POINTS FOR INSULATION ▪ BUS BAR SUPPORT SCREWS INSERTION POINTS



CAUTION!

For each installation step, there will be icons highlighting the protective equipment required, considering the minimum safety level necessary to correctly and safely perform the activities described. These requirements must be integrated with standards in force regarding safety at work and pertinent to the country where the machine is installed, as well as with any improvements resulting from experience and good practice techniques.

1.12. SHIPPING CONFIGURATION

The lift installation kit is generally contained in 2/3 safely packed boxes; the overall size of the pack depends on the number of stanchions.

The 2/3 boxes contain respectively (from the top of the pack to the bottom):

- Feet + feet accessories (each box can contain a maximum of 16/17 stanchions);
- Tractor unit + Accessories, Frame + Platform unit, Casing unit, Electric panel.

The above-mentioned components are installed in the following chronological order:

- Feet;
- Electrical panel;
- Tractor unit;
- Frame + Platform unit
- Accessories;
- Casing unit.



IMPORTANT!

It is recommended to open the various boxes containing the components only shortly before their assembly.

Note: the guide consists of a bottom and top rail, both manufactured in several pieces (for easy transportation) and packed separately.

The two images below show what the machine and its packed components could look like.



[PAGE INTENTIONALLY LEFT BLANK]

2. DESCRIPTION OF THE MACHINE



IMPORTANT!

The presence of some components can change according to the market of destination and to standards in force.

2.1. COMPONENTS LIST

The machine on a whole consists of the following components:

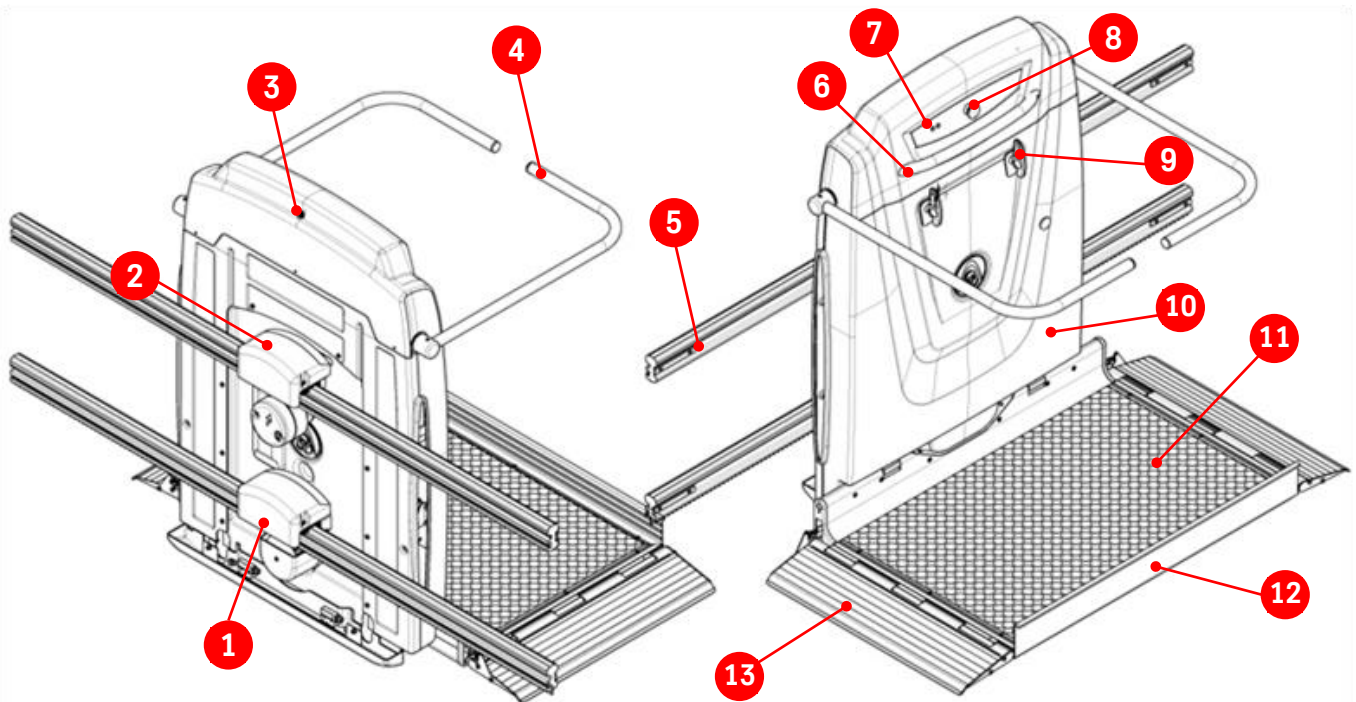

POS.	DESCRIPTION
1	LOWER CARRIAGE
2	UPPER CARRIAGE
3	FUSE
4	SAFETY BAR
5	GUIDE
6	HANDLE
7	CHECK PANEL
8	EMERGENCY BUTTON
9	ON-BOARD CONTROLS (ERGONOMIC KEY OR BUTTONS)
10	MACHINE BODY

11	PLATFORM
12	FIXED RESTRAINT / SIDE FLAP
13	MOBILE FLAP

3.ASSEMBLY OF THE MACHINE

3.1. MACHINE ASSEMBLY PROCEDURE

To correctly assemble the lift, follow the phases in the table in order referring to assembly/installation of the various components. A specific sheet describes the operations and procedures required to complete every stage.

STAGE	OPERATION DESCRIPTION	ASSEMBLY SHEET OF REFERENCE
1	ASSEMBLY OF RAIL STANCHIONS	INS-SUP-01
2	POSITIONING OF RAIL STANCHIONS	INS-SUP-02
3	POSITIONING AND FIXING BOTTOM RAIL	INS-SUP-03
4	JOINING RAIL	INS-SUP-04
5	BOTTOM RAIL ADJUSTMENT	INS-SUP-05
6	POSITIONING, FIXING AND ADJUSTING TOP RAIL	INS-SUP-06
7	FINAL ADJUSTMENTS AND CONTROLS OF RAILS	INS-SUP-07
8	FIXING STANCHIONS	INS-SUP-08
9	SEALING JOINT	INS-SUP-09
10	ELECTRICAL CONNECTION	INS-SUP-10
11	ASSEMBLY OF SELF-BEARING SUPPORT	INS-SUP-11
12	DECOUPLING THE MACHINE	INS-SUP-12
13	INSERTING TRACTOR UNIT ON RAIL	INS-SUP-13
14	FIXING BRUSHES	INS-SUP-14
15	MOVEMENT OF THE TRACTOR UNIT	INS-SUP-15
16	ASSEMBLING TRACTOR UNIT TO FRAME	INS-SUP-16
17	INSTALLATION OF ANTI-CRUSHING FRAME	INS-SUP-17
18	PLATFORM ADJUSTMENT	INS-SUP-18
19	INSTALLATION OF CAMS AND MECHANICAL STOP	INS-SUP-19
20	ADJUSTMENT OF LOAD CONTROL DEVICE (OPTIONAL)	INS-SUP-20
21	INSTALLATION OF REAR CARRIAGE CASINGS	INS-SUP-21
22	ASSEMBLY OF CASINGS	INS-SUP-22
23	INSTALLATION OF CALL DEVICES	INS-SUP-23
24	MAKING THE FIRST RUN	INS-SUP-24

**IMPORTANT!**

The installation phase can only be carried out correctly by following the specific installation layout supplied together with the machine. Open the layout so that it is visible and easy to consult.

**IMPORTANT!**

The rail must be installed starting from the top.

**IMPORTANT!**

- Before starting to install the rail, set up the stanchions supporting the top and bottom guide.
- During the initial installation phases of the rail, the stanchions must be positioned temporarily so that they can be adjusted before the final fixing of the guides.

**SAFETY! CAUTION!**

Close off the work area and material storage areas as far as possible. Interrupt work while people are passing.

**SAFETY! CAUTION!**

Before starting work, do an analysis of possible risks (LMRA: Last Minute Risk Analysis).

**SAFETY! CAUTION!**

Do not leave accessories or equipment unattended on the stairs or landings.

**SAFETY! CAUTION!**

If you must work near 220V components (e.g.: to analyse problems) use a suitable protection (e.g.: portable insulating rug).

**SAFETY! CAUTION!**

Additional PPE:

wear a helmet for stairs with open railings (risk of material falling on ramps below during installation).

**SAFETY! CAUTION!**

Additional PPE: use suitable harnessing when performing anchoring outside the stairs or to remove the handrail (with risk of falling down). Pay attention to the strength of the harnessing coupling point.

SHEET	OPERATION DESCRIPTION
INS-SUP-01	ASSEMBLY OF RAIL STANCHIONS

OPERATORS INVOLVED	1
---------------------------	---

TIME REQUIRED (minutes)	20
--------------------------------	----

NECESSARY PPE				DIFFICULTY LEVEL		
						

RECOMMENDED EQUIPMENT
<ul style="list-style-type: none"> ▪ 13mm spanner ▪ 13mm ratchet spanner

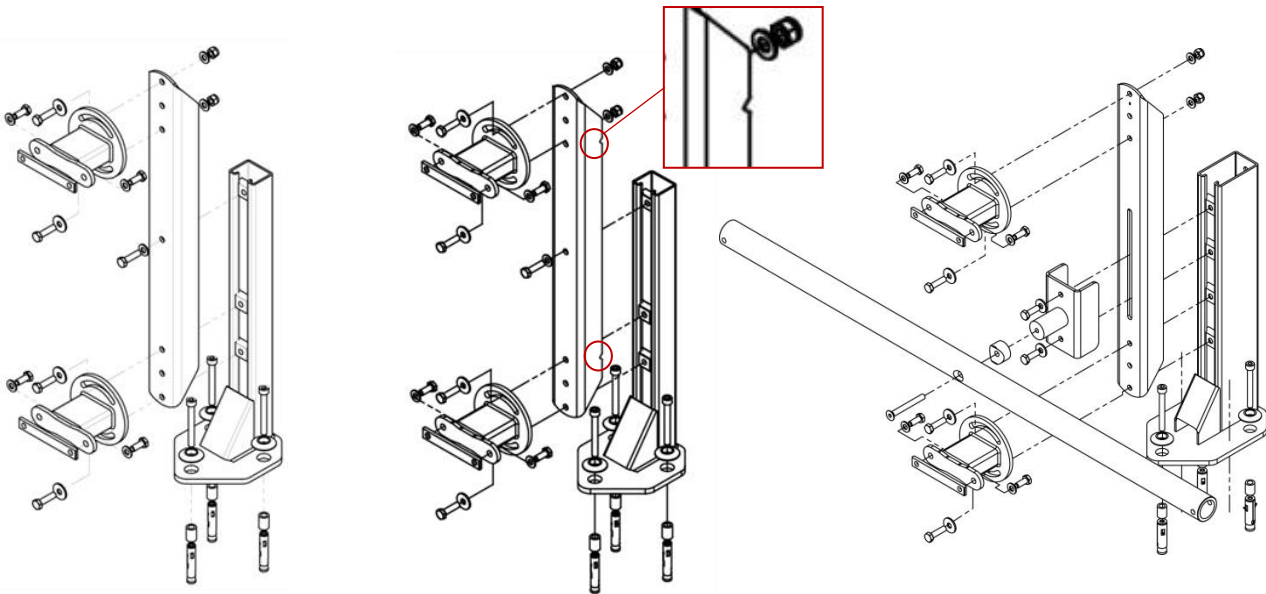

Standard version

"Short" version which can be used in rail sections with up to 15° gradient variation and in sections between 15° and 20°





Version for 3rd rail. Used in straight sections or between 0° and 15°



IMPORTANT!

Follow the job order drawing attached to the system to assemble the stanchions. The stanchions and registers have different measurements and therefore the combinations could be different.

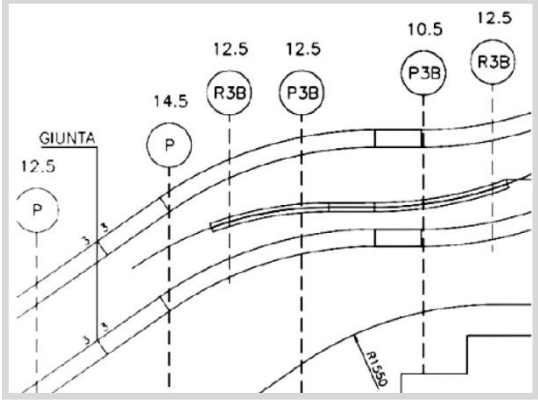
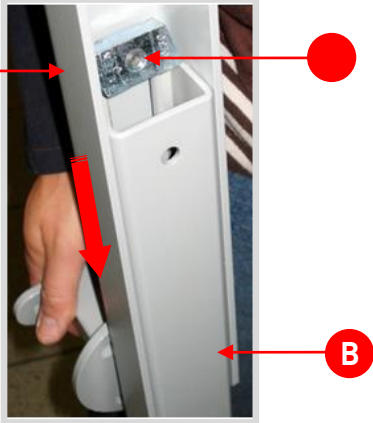
To assemble a stanchion, proceed as follows:

STAGE	DESCRIPTION	IMAGE
1	<p>The stanchions differ by height (indicated on the drawing in dm and at the bottom of the stanchion) and by coupled register type</p> <p>  standard  reduced  with III rail appendix. </p> <p>According to the drawing, appropriately combine the components as described below</p> <p>Note: The height of the stanchions is stamped on the hidden side of the base plate.</p>	
2	<p>Insert the register (A) sliding it from the top inside the fixed profile (B) and paying attention to position the special nuts correctly (C).</p>	
3	<p>Slide the register (A) and insert the remaining special nuts.</p> <p>Note: the register does not need to be secured in the fixed part of the stanchion because the exact height will be adjusted in the following installation steps.</p>	
4	<p>Complete the assembly of all the stanchions.</p>	

SHEET	OPERATION DESCRIPTION
INS-SUP-02	POSITIONING OF RAIL STANCHIONS

OPERATORS INVOLVED	1
--------------------	---

TIME REQUIRED (minutes)	5
-------------------------	---

NECESSARY PPE				DIFFICULTY LEVEL		
						

RECOMMENDED EQUIPMENT
<ul style="list-style-type: none"> ▪ Drawing ▪ Marker







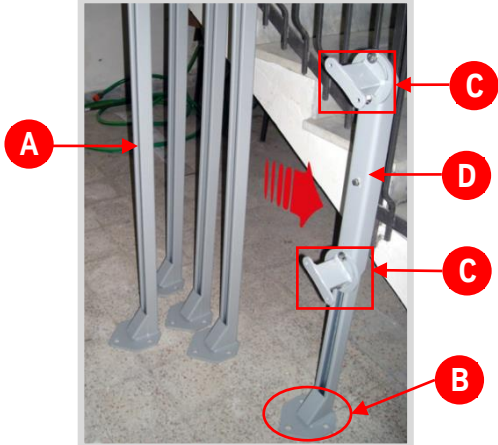

IMPORTANT!

Position the stanchions on the steps without fixing them as expressly indicated in the job order drawing attached to the system.

To position the stanchions, proceed as follows:

STAGE	DESCRIPTION	IMAGE
1	Follow the layout to arrange the stanchions in the right position.	
2	<p>The fixed profile (A) must be anchored to the ground on the step by means of the specific bores (B).</p> <p>The two adjustable supports (C) at the ends of the register (D) connect the stanchions and the guides (upper and lower).</p>	

SHEET	OPERATION DESCRIPTION					
INS-SUP-03	POSITIONING AND FIXING BOTTOM RAIL					
OPERATORS INVOLVED	2					
TIME REQUIRED (minutes)	5					
NECESSARY PPE						
						
DIFFICULTY LEVEL						
RECOMMENDED EQUIPMENT						
<ul style="list-style-type: none"> ▪ 19mm ratchet spanner ▪ 4mm Allen wrench 						

**IMPORTANT!**

This procedure must be done after the stanchions have been positioned. Position the segments again starting from the top.

**IMPORTANT!**

The number of segments can be read on the side of the rails which is joined to the other pieces.

**IMPORTANT!**

Two types of blocks are supplied:

- Short (A): used in pairs and near gradient variations of the guide and/or to fix accessories such as the electric terminal and closing column of the rail.
- Long (B): on the other sections.



**SAFETY! CAUTION!**

Always check for piping or other installations before drilling.

**SAFETY! CAUTION!**

It always takes 2 people to handle the rail. When carrying it to the upper floors, the taller of the two must carry the straight part.

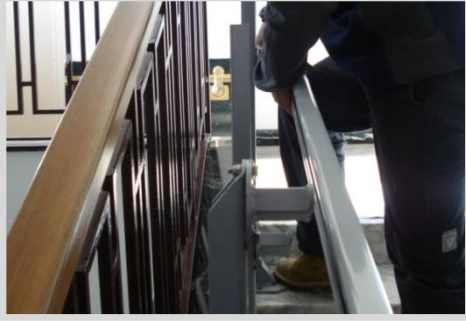
To position the bottom rail, proceed as follows:

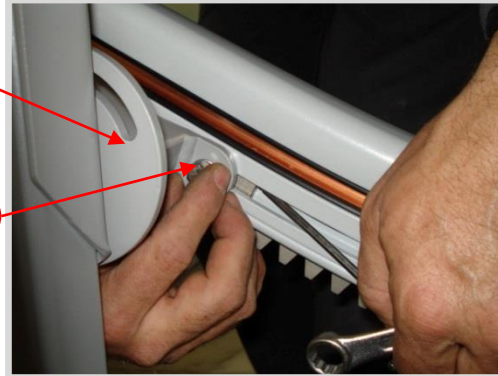
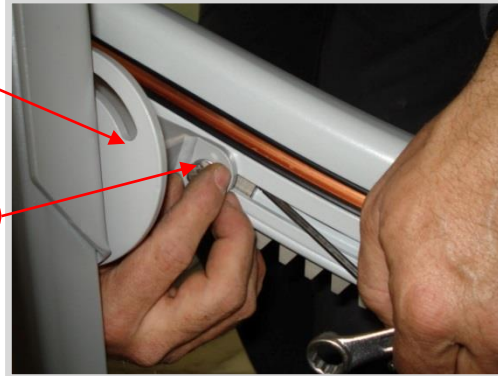
STAGE	DESCRIPTION	IMAGE
1	Position segment number 1. Note: The bottom rail is equipped with rack	
2	Remove the grub screws from the guide which secure the blocks of the lower conduit to it and move the blocks (A) so that they match the holes of the adjustable support.	
3	Secure the rail by screwing the adjustable supports (B) to the blocks (A).	
4	Clamp the blocks and registers with the M8 hex head screw (C).	
5	Secure all the other points of the segment with the relative stanchions.	-
6	Perform all the adjustments.	-

7







Tighten the middle screws **(D)** to block the register at the desired height.

**IMPORTANT!**

The height and inclination of the rail is adjusted by the register and by the adjustable support slots which connect the rail to the stanchion.

**SAFETY! CAUTION!**

Mount the bottom rail **BEFORE** having mounted the corresponding section of the top rail (e.g.: lower section n°3; the upper section n° 3 must **NOT** be present, but only n°2).

SHEET	OPERATION DESCRIPTION	
INS-SUP-04	JOINING RAIL	
OPERATORS INVOLVED	2	
TIME REQUIRED (minutes)	5	
NECESSARY PPE		
		
	DIFFICULTY LEVEL	
		
RECOMMENDED EQUIPMENT		
<ul style="list-style-type: none"> ▪ Hand saw ▪ File ▪ 13mm spanner 	<ul style="list-style-type: none"> ▪ Small plastic flat-head screwdriver ▪ Tape measure 	
LEVEL OF CRITICALITY		
▪ HIGH		

**CAUTION!**



Performing these operations incorrectly would jeopardise final installation of the machine. Therefore you must pay the utmost attention in carrying out the procedures described below.

**IMPORTANT!**

The junction must not have sharp edges and/or burrs. The presence of a joint with sharp edges and/or burrs jeopardises proper operation of the lift.

To install the rail joint, proceed as follows:

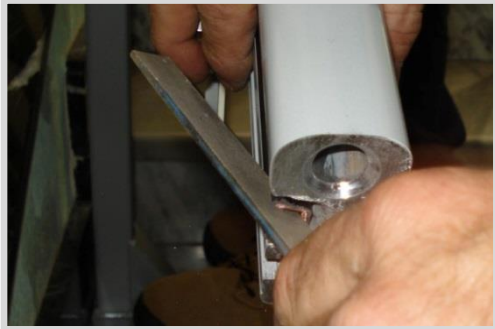
STAGE	DESCRIPTION	IMAGE
1	<p>Position the block (A), used for the electrical connection, near the zone of the rail where the two segments will be joined.</p> <p>The block keeps the joint from completely entering the segment of the rail already installed.</p>	

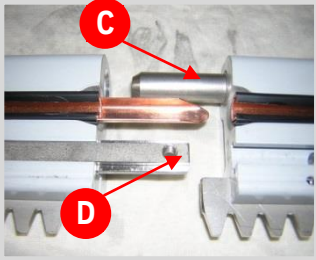
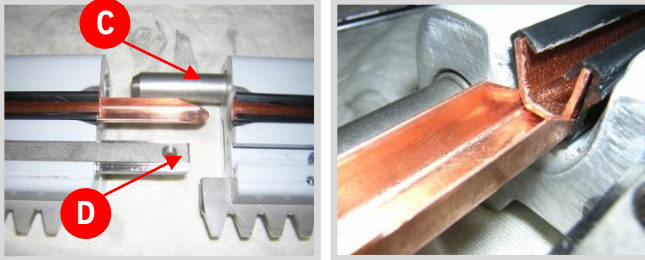
2	Eliminate the copper bus bar part in excess using a saw.	
3	File the cut part of the bus bar to eliminate burr or impurity.	
4	The two ends must appear as shown in the figure to the side before being joined.	
5	Repeatedly insert and remove the copper plate (B) between the bus bar and insulation to create space.	
6	Insert the pin (C) in the piece of rail which must be installed.	
7	Insert the metal block (D - "T"-section) on the part of the guide just installed.	
8	Once the first segment of the rail has been fixed, position the second segment.	-
9	Join the two segments.	

To complete the joint, proceed as follows:



IMPORTANT!

The plastic insulation between the junction plate and the guide:

- is a spacer;
- contains the bottom part of the bus bar.

STAGE	DESCRIPTION	IMAGE
10	<p>Tighten the two special M8 screws (E), to fix the rail junction plate.</p> <p>Note: Tighten one screw partially and then the other and so on until it is completely clamped. Do not completely clamp one screw and then the other.</p> <p>Check that the two segments of the rail are coupled stably and then tighten the screws definitively.</p>	
11	<p>Insert the two plastic grub screws M6 (F) and turn them with a flat-head screwdriver to tighten them slightly.</p>	

IMPORTANT!









Test conditions of the installation whenever possible and not only when the entire rail has been installed.



Check the condition of the bus bar by performing the following tests:

- check continuity between the two joined segments of the bus bar (upper and lower);
- check insulation between the bus bar and aluminium profile of the rail (top and bottom);
- check for short circuits between the upper and lower bus bar.





SHEET	OPERATION DESCRIPTION	
INS-SUP-05	BOTTOM RAIL ADJUSTMENT	
OPERATORS INVOLVED	2	
TIME REQUIRED (minutes)	5	
NECESSARY PPE		
		
		
DIFFICULTY LEVEL		
		
RECOMMENDED EQUIPMENT		
<ul style="list-style-type: none"> ▪ Goniometer with spirit level ▪ 13mm spanner ▪ Tape measure 		



IMPORTANT!

Perform the necessary measurements of the rail before installing the first rail segment with a bend.







To adjust the top and bottom rail, proceed as follows:

STAGE	DESCRIPTION	IMAGE
1	While referring to the job order drawing, adjust the height of the bottom rail (and then the top).	
2	Adjust the height of the bottom rail (and then the top) by acting on the stanchion register (A).	

3

Check the inclination of the guide by using the goniometer with spirit level.



SHEET	OPERATION DESCRIPTION	
INS-SUP-06	POSITIONING, FIXING AND ADJUSTING TOP RAIL	
OPERATORS INVOLVED	2	
TIME REQUIRED (minutes)	5	
NECESSARY PPE		
		
		
		
DIFFICULTY LEVEL		
RECOMMENDED EQUIPMENT		
<ul style="list-style-type: none"> See previous sheets regarding positioning, adjusting and controls of bottom rail 		







To perform the **final checks**, proceed as follows:

STAGE	DESCRIPTION	IMAGE
1	Proceed as indicated above for positioning, adjustments and controls for the bottom rail.	-





SAFETY! CAUTION!

Mount the bottom rail **BEFORE** having mounted the corresponding section of the top rail (e.g.: lower section n°3; the upper section n° 3 must **NOT** be present, but only n°2).

SHEET	OPERATION DESCRIPTION
INS-SUP-07	FINAL ADJUSTMENTS AND CONTROLS OF RAILS
OPERATORS INVOLVED	1
TIME REQUIRED (minutes)	5
NECESSARY PPE	
	
	
DIFFICULTY LEVEL	
	
	
RECOMMENDED EQUIPMENT	
<ul style="list-style-type: none"> ▪ Spirit level ▪ Shims (if necessary) 	<ul style="list-style-type: none"> ▪ 13mm spanner







To perform the **final checks**, proceed as follows:

STAGE	DESCRIPTION	IMAGE
1	Check that the stanchions and rails are vertical.	
2	Pay attention to sections of the rail with bends and gradient variations.	
3	After having installed the rail, repeat the continuity check on the joints.	-



IMPORTANT!

Once the rail has been completely installed and adjusted, apply grease on the rack near the bends to facilitate passage of the lift on the guide.



SHEET	OPERATION DESCRIPTION
INS-SUP-08	FIXING STANCHIONS
OPERATORS INVOLVED	1
TIME REQUIRED (minutes)	5
NECESSARY PPE	
	
	
DIFFICULTY LEVEL	
	
	
RECOMMENDED EQUIPMENT	
<ul style="list-style-type: none"> ▪ Drill ▪ 14mm drill bit ▪ Hammer 	<ul style="list-style-type: none"> ▪ Plunger pump ▪ Brush ▪ Spanner to clamp plugs

Perform the **final checks**:



IMPORTANT!

If the machine is supplied with a third rail, see the supplied instructions for any variations in the assembly procedure.

STAGE	DESCRIPTION	IMAGE
1	Drill the necessary holes to fix the stanchion.	
2	Make sure that the stanchion is positioned correctly.	-
3	Insert the plugs and secure the stanchions while referring to the tightening torques in the "tightening parts" chapter	 

4

It is recommended to perform additional fastening where possible to improve stability of the rail.



SHEET	OPERATION DESCRIPTION
INS-SUP-09	SEALING JOINT
OPERATORS INVOLVED	1
TIME REQUIRED (minutes)	5
NECESSARY PPE	
DIFFICULTY LEVEL	
RECOMMENDED EQUIPMENT	
<ul style="list-style-type: none"> ▪ Polyurethane cartridge ▪ Cloth ▪ Small plastic flat-head screwdriver ▪ Caulking gun 	
LEVEL OF CRITICALITY	
<ul style="list-style-type: none"> ▪ TOP 	





CAUTION!

Performing these operations incorrectly would jeopardise final installation of the machine. Therefore you must pay the utmost attention in carrying out the procedures described below.







Seal the joint:

STAGE	DESCRIPTION	IMAGE
1	Using the supplied polyurethane cartridge, inject insulating material through the hole shown to the side.	
2	For proper sealing, only a small amount of polyurethane needs to come out (A). Leave it to dry before removing excess material.	
3	Check that the bus bar is clean.	-

4	The sealant fills empty gaps and provides a further layer of insulation behind the joint.	
5	Clean the bus bar using a napkin to remove oil and processing residue.	



SAFETY! CAUTION!
Be careful to reduce direct contact of polyurethane with skin.

SHEET	OPERATION DESCRIPTION
INS-SUP-10	ELECTRICAL CONNECTION
OPERATORS INVOLVED	1
TIME REQUIRED (minutes)	5
NECESSARY PPE	
	
	
DIFFICULTY LEVEL	
	
	
RECOMMENDED EQUIPMENT	
<ul style="list-style-type: none"> ▪ Drill ▪ 14mm drill bit ▪ Hammer 	<ul style="list-style-type: none"> ▪ Plunger pump ▪ Spirit level ▪ Polyurethane cartridge



**IMPORTANT!**

Before performing the electrical connection, install the metal container for the electric panel.

**IMPORTANT!**



The electric panel must be installed in a sheltered or partially exposed area (shelter, roof or technical compartment). It can only be installed outdoors if expressly indicated (stainless steel version and/or with ventilation accessories). For outdoor installation, it is always advisable to provide a protective roof and spacers to avoid the thermal bridge effect with the wall.

To install the container proceed as follows:

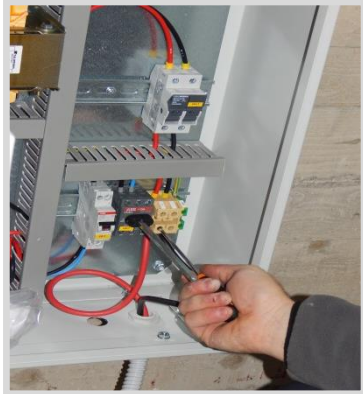
STAGE	DESCRIPTION	IMAGE
1	Fix the panel to the wall at a height accessible for the User. Leave 15 cm of space below the panel. For outdoor installation, it is recommended to apply spacers behind the panel to avoid direct contact with the wall.	
2	The panel is equipped with a circuit breaker switch and consists of a metal container the following size: <ul style="list-style-type: none"> • 400x500x200 (standard version) • 500x700x200 (anti-blackout version) 	

<p>3</p>	<p>It can be installed indifferently on either end of the guide within 5 m to avoid excessive voltage drops.</p>	
<p>4</p>	<p>Insert the two cables inside and fix them to the terminal board.</p>	

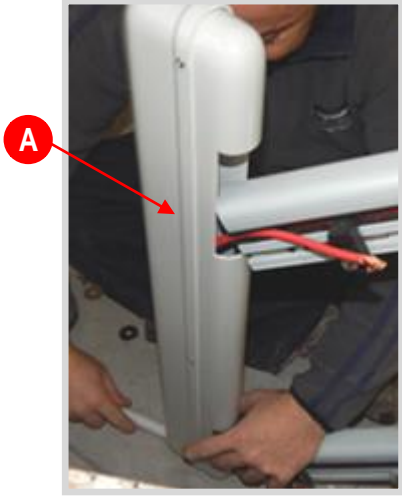
To **install the column and electric cables** proceed as follows:

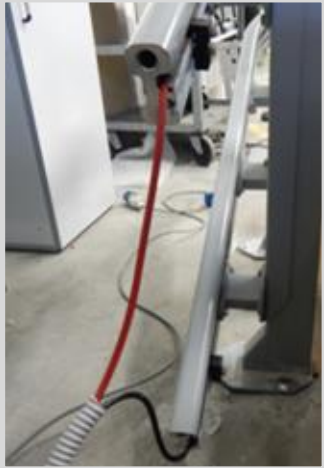
STAGE	DESCRIPTION	IMAGE
<p>5</p>	<p>The two power cables (minimum cross-section 16 mm² or AWG 6) leaving the electric panel must be brought to the column (A) appropriately protected inside a conduit and/or supplied corrugated conduit. Make a circular opening on the side of the column 40-50 mm high to insert the corrugated conduit and the wires.</p>	
<p>6</p>	<p>Cut the end part of the column, if necessary, to correctly arrange the components.</p>	
<p>7</p>	<p>Perform the operations for the electrical connection of the rail.</p> <p> IMPORTANT! Connect the positive pole (+) to the upper bus bar and the negative pole (-) to the lower bus bar.</p>	

8

From the side with housings for the rail profiles, fix the column with the two shaped washers (**B**) and relative lock nuts. The tooth of the washer must be positioned on the plastic of the column.



9

A fixing plate and relative nuts and bolts are provided for the top stop column.
Note: Definitively fix the column of the upper floor at the end of machine installation.

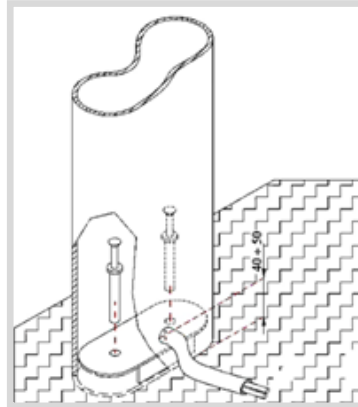

10

Pass the wires from the column to the copper conduit on the rail profiles. Cut a 5-6 cm wire and peel it 1.5-2 cm.



11

Insert the wire into the copper conduit. Fix the column to the rail using the supplied nut and washer.



12

Position the plastic cable gland block on the uncovered part of the wire. Fix the cable gland using the mobile blocks in the lowest conduit of the rail profiles.

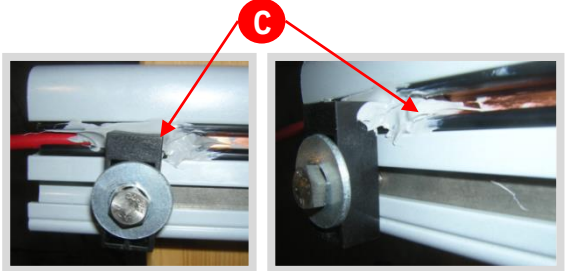

<p>13</p>	<p>Once the necessary connections have been made, close the column using the outer enclosure.</p>	
<p>14</p>	<p>Apply liquid polyurethane (C) to keep the contact between the cable and bus bar from oxidising.</p> <p>Note: This polyurethane is also used for the electrical insulation of the joint.</p>	









CAUTION!

To drive the lift, the main Electric Panel must be powered electrically. Remember that, when the final connection made by a specialised company under the responsibility of the property owner and relative certification are missing, the installer can only temporarily power the main EP with a "temporary" cable with connections made appropriately and safely, making sure that no one enters into contact with live parts during this operation. At the end of these operations, the temporary electric power supply must be removed, leaving it to the specialist appointed by the customer to perform the final electrical connection.



SAFETY! CAUTION!

It is possible to use an intermediate worksite Panel, with specific residual current device between the customer's EP and the main Electric Panel of the machine.

SHEET	OPERATION DESCRIPTION					
INS-SUP-11	ASSEMBLY OF SELF-BEARING SUPPORT					
OPERATORS INVOLVED	1					
TIME REQUIRED (minutes)	20					
NECESSARY PPE				DIFFICULTY LEVEL		
						
RECOMMENDED EQUIPMENT						
<ul style="list-style-type: none"> ▪ 13mm spanner ▪ Self-bearing support 						

**IMPORTANT!**

Skip this procedure if the machine is already equipped with a support mounted in the factory.

To assemble the self-bearing support, proceed as follows:

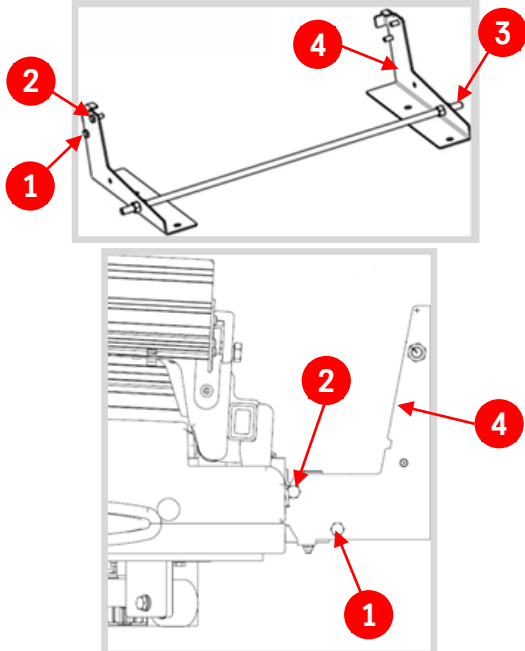
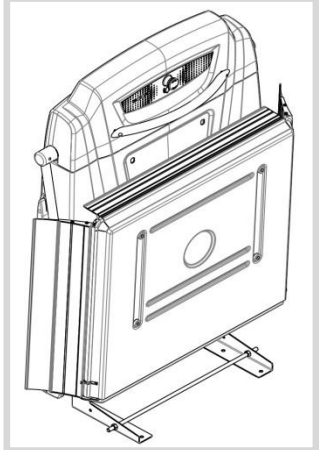
STAGE	DESCRIPTION	IMAGE
1	Set the machine horizontally.	-
2	<p>Fix the threaded bar (3) and secure the screws (1) and (2) to the machine.</p> <p>Note: Pay attention not to deform the supports (4) when clamping the screws.</p>	
3	Bring the machine to the upright position.	

SHEET	OPERATION DESCRIPTION
INS-SUP-12	DECOUPLING THE MACHINE

OPERATORS INVOLVED	2
---------------------------	---

TIME REQUIRED (minutes)	20
--------------------------------	----

NECESSARY PPE				DIFFICULTY LEVEL		
						

RECOMMENDED EQUIPMENT	
<ul style="list-style-type: none"> ▪ 13mm hex wrench ▪ Socket wrench with 13mm ratchet ▪ T-wrench with 13mm socket ▪ PH3 screwdriver 	<ul style="list-style-type: none"> ▪ Electrician's scissors ▪ Handles ▪ Self-bearing support





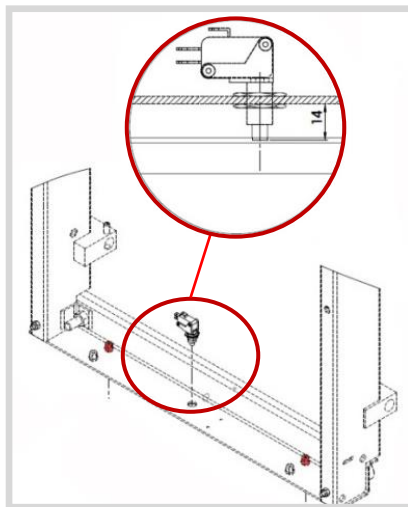

IMPORTANT!

A trolley should be used to handle the machine, paying attention to the microswitch at the bottom of the frame which could be damaged during this operation.

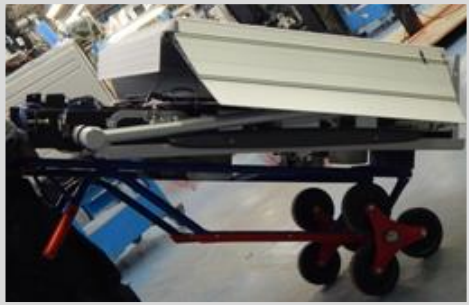

To decouple the machine, proceed as follows:

STAGE	DESCRIPTION	IMAGE
1	Place the lift near the stairs in a dry and flat area.	
2	Remove the 4 screws on the sides of the frame.	
3	Position the two polystyrene slats (inside the packaging) and set the lift on them.	
4	Open the lift.	

5

Disconnect the electric connections:

- J6, J7, X1 from the mainboard D-203
- X11 and X12 (if present) from the mainboard D-203
- X10 if there is a load cell
- OSG and J8 from the connector panel



6

Remove the screws joining the tractor unit to the frame.

Note: Keep the screws with relative washers to reconnect the tractor-frame.

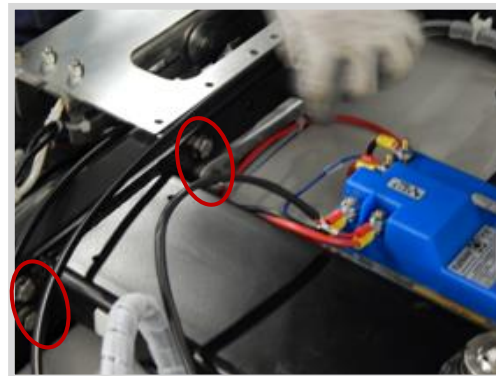

7

Lift the frame (A), rotating it around the base of the self-bearing support. This separates the frame from the tractor unit (B).

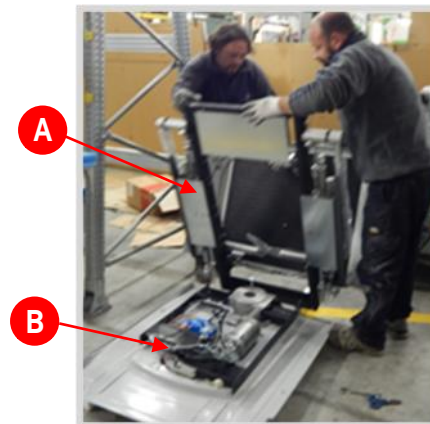



8

Fix the specific handles, included in the installation kit, on the sides of the tractor unit using the supplied screws.

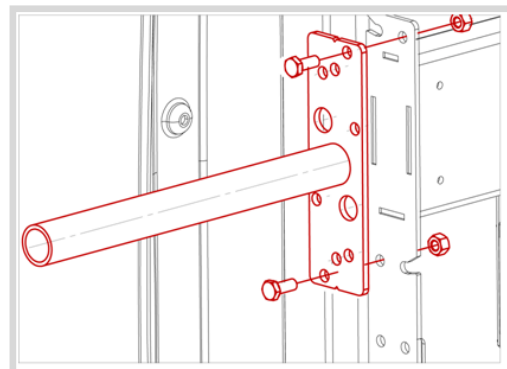

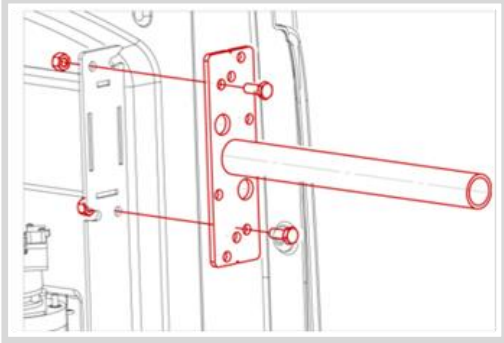

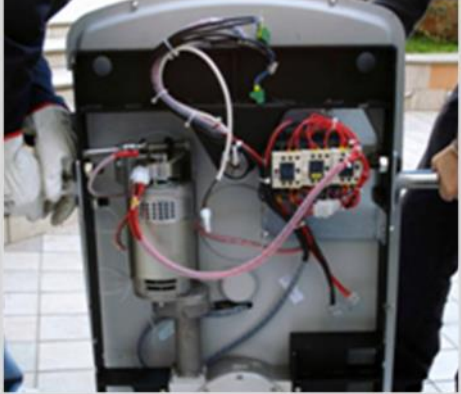
Note: The holes have different patterns. Make sure to insert the screws in the correct holes.





		
9	The carriages are already equipped with two rail segments to facilitate insertion of the tractor unit on the rail.	
10	Lift the tractor unit and bring it to the top of the rail for the insertion procedure.	



**SAFETY! CAUTION!**

Tighten the connection bolts between the handles and tractor appropriately. Before bringing the tractor unit to the top of the rail, check that the path has NO obstacles and creates no risk of tripping.

SHEET	OPERATION DESCRIPTION	
INS-SUP-13	INSERTING TRACTOR UNIT ON RAIL	
OPERATORS INVOLVED	2	
TIME REQUIRED (minutes)	20	
NECESSARY PPE		
		
		
RECOMMENDED EQUIPMENT		
<ul style="list-style-type: none"> ▪ Tube of grease 		

To insert the machine on the rail, proceed as follows:

STAGE	DESCRIPTION	IMAGE
1	Place the tractor unit at the top part of the rail. Insert the supplied pins and then couple the two rail segments on the two carriages.	
2	Slide the tractor unit on the guides. Perform these manoeuvres slowly to avoid triggering the parachutes.	

3	<p>As soon as the pinion touches the rack, it is blocked.</p> <p> IMPORTANT! At this point you must use the handwheel for manual emergency manoeuvring to complete insertion of the tractor unit on the guides.</p>	
4	<p>Remove the two rail segments that were on the two carriages.</p>	

**SAFETY! CAUTION!**







Before inserting the tractor unit on the rail, make sure there are end stroke screws on the segments.

**SAFETY! CAUTION!**



Be careful NEVER to place your hands in the space between the rail and guide segments or the tractor itself.

**SAFETY! CAUTION!**

Make sure it is possible to insert the entire tractor before the pinion comes into contact with the rack.

SHEET	OPERATION DESCRIPTION
INS-SUP-14	FIXING BRUSHES
OPERATORS INVOLVED	1
TIME REQUIRED (minutes)	20
NECESSARY PPE	
	
	
DIFFICULTY LEVEL	
	
	
RECOMMENDED EQUIPMENT	
<ul style="list-style-type: none"> ▪ 2 13mm hex wrenches ▪ 10mm socket wrench 	<ul style="list-style-type: none"> ▪ 2 Rubber mallets

To fix the brushes, proceed as follows:

STAGE	DESCRIPTION	IMAGE
1	Fix the brushes to the respective carriages.	
2	<p>The brush of the upper carriage and that of the lower carriage require different adjustments. This depends on their different distance from the guide.</p> <p>The brush holder unit of the upper carriage and that of the lower carriage are different one from another. To help identify them, they have different colours: the upper one is green and the lower one black.</p>	
3	Check that the electric cables coming from the brushes are free of interferences, have small bends and are well fixed to the terminal.	

SHEET	OPERATION DESCRIPTION
INS-SUP-15	MOVING THE TRACTOR UNIT
OPERATORS INVOLVED	1
TIME REQUIRED (minutes)	5
NECESSARY PPE	
DIFFICULTY LEVEL	
RECOMMENDED EQUIPMENT	
<ul style="list-style-type: none"> ▪ 13mm hex wrench 	

When the adjustments in the previous points have been performed, the machine can be moved using the tractor unit driver.

This procedure can also be used with the machine coupled by disconnecting the X1 connector or pressing the emergency button.

To **move the machine**, proceed as follows:

STAGE	DESCRIPTION	IMAGE
1	Power the machine. Within 30 seconds, press the buttons on the driver to move up and down, (A) and (B) simultaneously for 3 seconds. The green LED (C) starts to flash.	
2	Keep one button pressed (the top one to move up or the bottom one to move down) based on the movement to be performed. The green LED remains on steady. Note: releasing all the buttons for even one instant stops movement. To restart manual mode, you must repeat the procedure.	

<p>3</p>	<p>Reach the bottom floor and stop the run.</p>	<p>-</p>
<p>4</p>	<p>Remove the handles mounted previously.</p>	



SAFETY! CAUTION!

When moving the tractor unit, be careful that no one is in the trajectory.

Pay attention NOT to place your stanchions or anything else in the arrival area of the tractor to avoid the risk of crushing.

SHEET	OPERATION DESCRIPTION
INS-SUP-16	ASSEMBLING TRACTOR UNIT TO FRAME

OPERATORS INVOLVED	2
--------------------	---

TIME REQUIRED (minutes)	20
-------------------------	----

NECESSARY PPE				DIFFICULTY LEVEL		
						

RECOMMENDED EQUIPMENT
<ul style="list-style-type: none"> ▪ 13mm hex wrench ▪ Socket wrench with 13mm ratchet ▪ T-wrench with 13mm socket ▪ 10mm hex wrench



IMPORTANT!
Tighten the screws appropriately to guarantee ideal operation of the unit.

To assemble the tractor unit to the frame, proceed as follows:

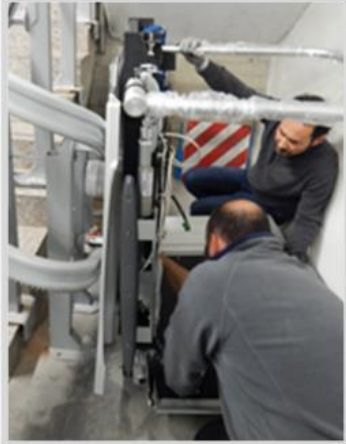
STAGE	DESCRIPTION	IMAGE
1	Approach the frame to the tractor unit. Assembly of the parts is facilitated by the self-bearing support (A) , placing both units at the same level.	
2	Use the screws removed previously. Initially screw 2 or 3 on each side to stabilise the two units and to facilitate insertion of all the other screws. Note: Apply a small amount of “medium threadlocker” (supplied) to each screw.	

3

Restore the connections disconnected previously.









4

Check that all the pins of the wheels are clamped correctly. The end of the pin mounted with the elastic bushings in the red tyre must be flush with the self-locking nuts; in this configuration the red tyres appear partially pressed. For the other pins they must be well tightened.

**SAFETY! CAUTION!**

This operation requires 2 persons, positioned on the short sides of the platform. Always leave the frame in contact with the ground on the stanchions (do NOT lift it to couple it).

SHEET	OPERATION DESCRIPTION		
INS-SUP-17	INSTALLATION OF ANTI-CRUSHING FRAME		
OPERATORS INVOLVED	1		
TIME REQUIRED (minutes)	5		
NECESSARY PPE			
   	<th colspan="2">DIFFICULTY LEVEL</th>	DIFFICULTY LEVEL	
	  		
RECOMMENDED EQUIPMENT			
<ul style="list-style-type: none"> ▪ 10mm hex wrench ▪ 12mm hex wrench 	<ul style="list-style-type: none"> ▪ 4mm Allen wrench 		

To install the anti-crushing frame, proceed as follows:

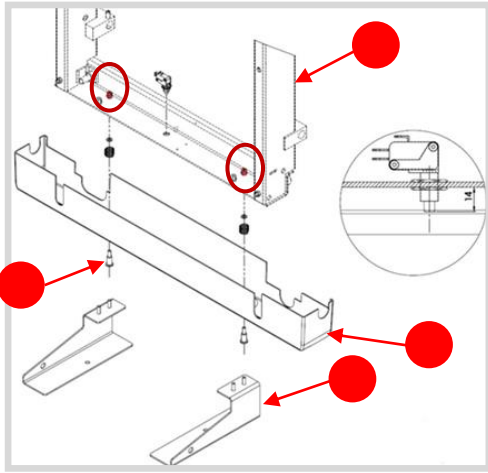
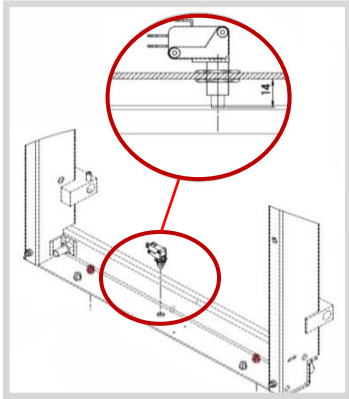
STAGE	DESCRIPTION	IMAGE
1	Lift the machine off the ground.	
2	Remove the self-bearing support (1) (if not already removed).	
3	Connect the anti-crushing frame (A) to the machine frame (2) using the screws (3) on the rivets highlighted in red.	
4	Check that the head of the microswitch is 14mm below the frame.	
		



Warning! A safety interlock prevents the machine from being moved with the lateral mobile slide open. On first operation the platform must be forced closed before the machine can be moved.

SHEET OPERATION DESCRIPTION

INS-SUP-18 PLATFORM ADJUSTMENT

OPERATORS INVOLVED

1

TIME REQUIRED (minutes)

5

NECESSARY PPE



DIFFICULTY LEVEL



RECOMMENDED EQUIPMENT

- 19mm spanner

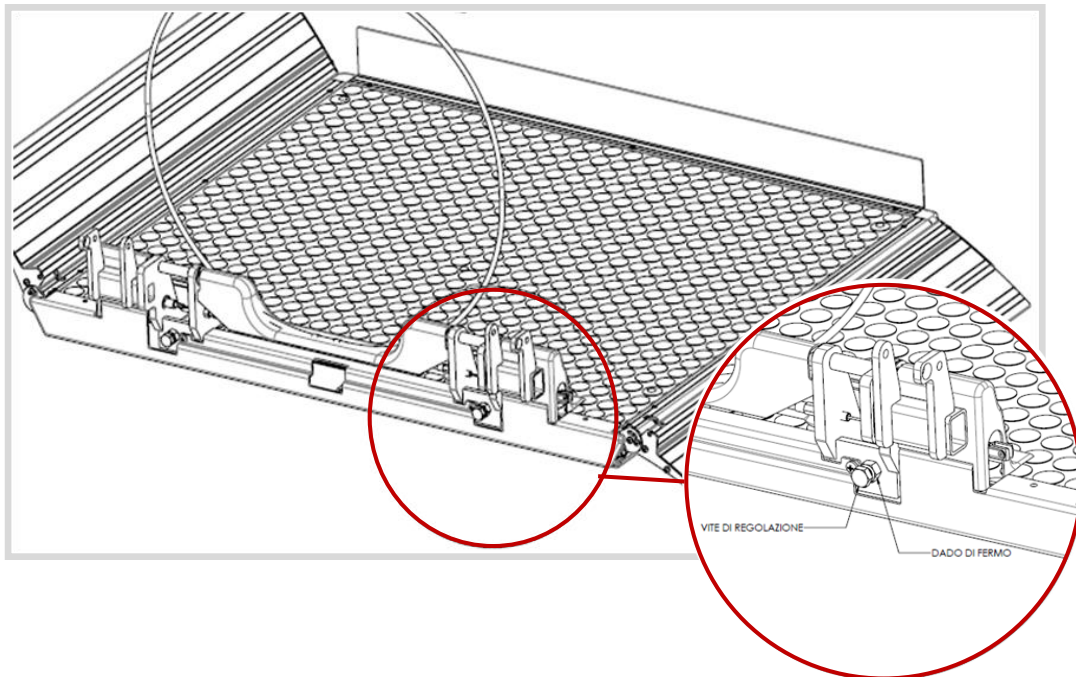
**IMPORTANT!**

Exact adjustment is achieved when the open platform, bearing a load, is at a 0° angle and slightly in contact with the ground.

The load must be equal to half the maximum capacity allowed or to the real use capacity.





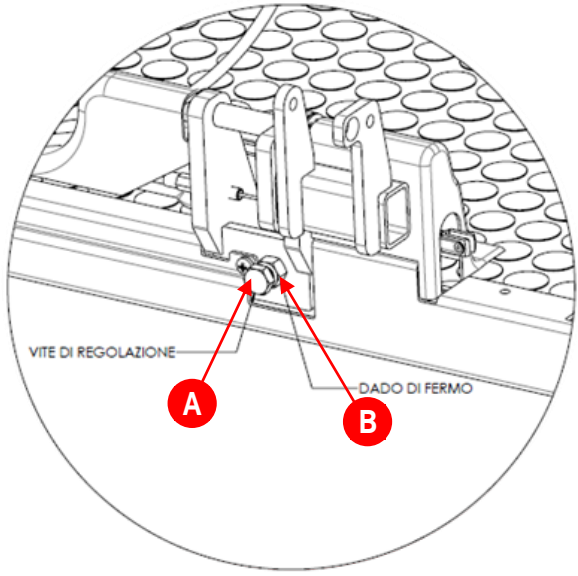

When empty, the platform must be slightly inclined upwards.

To adjust the platform, proceed as follows:

STAGE	DESCRIPTION	IMAGE
1	With the platform at the theoretical landing point, adjust its inclination by acting on the screws (A) .	
2	Make sure that both screws are tight. Use the lock nut (B) to block the screws.	



IMPORTANT!
Make sure that both stop points rest on the frame to discharge the load evenly.

SHEET	OPERATION DESCRIPTION
INS-SUP-19	INSTALLATION OF CAMS AND MECHANICAL STOP
OPERATORS INVOLVED	1
TIME REQUIRED (minutes)	20
NECESSARY PPE	
	
	
DIFFICULTY LEVEL	
	
	
RECOMMENDED EQUIPMENT	
<ul style="list-style-type: none"> ▪ 3mm Allen wrench 	

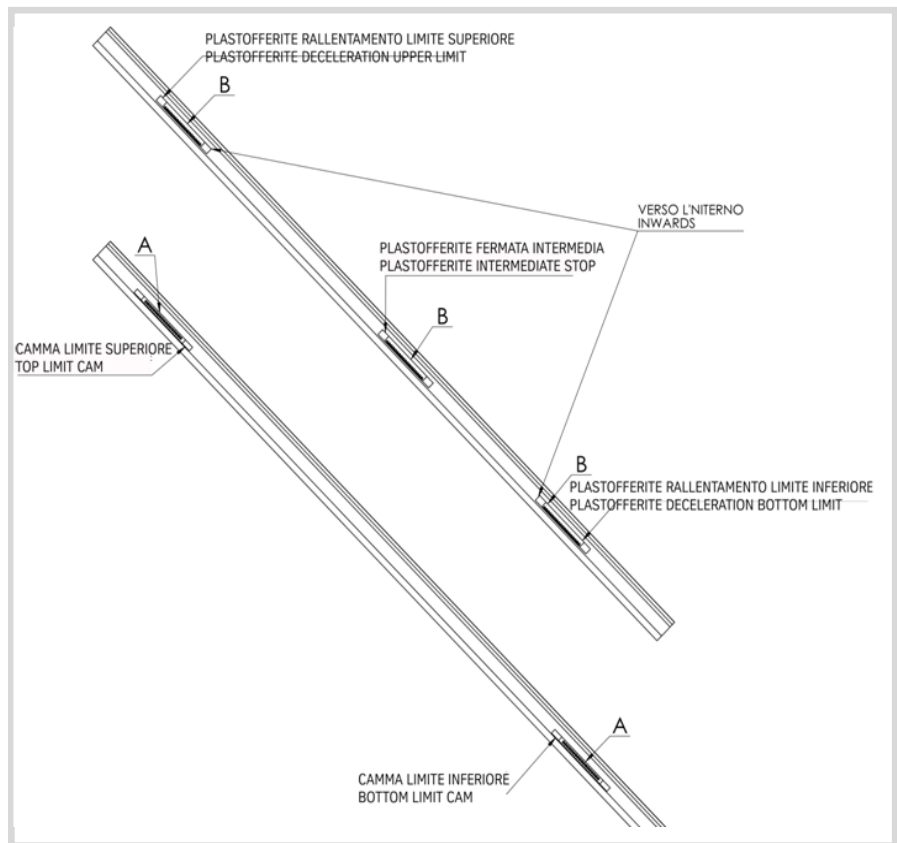

The drawing to the side shows an example of installation of the cams and plastroferrites.



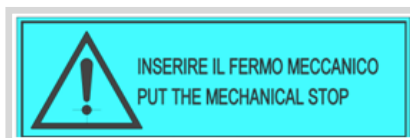



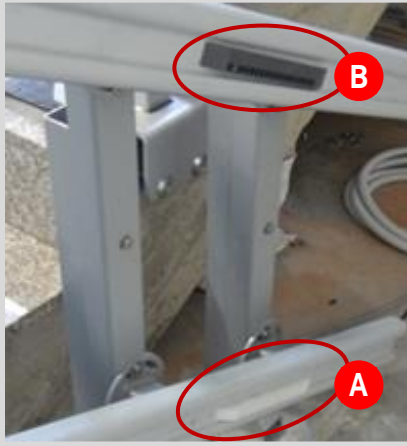

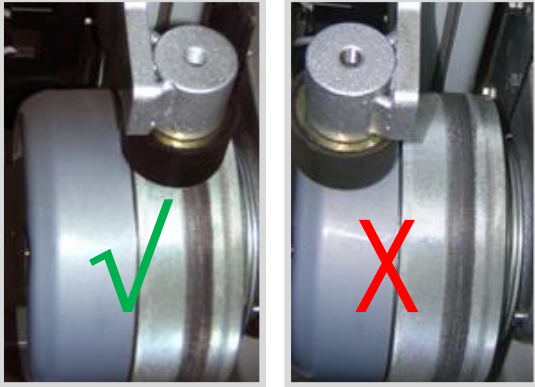

The mechanical stop has a sticker in the area where it must be installed.



To install the cams and the mechanical stop, proceed as follows:

STAGE	DESCRIPTION	IMAGE
1	The rail is supplied with holes.	
2	<p>Follow the relative drawing to position the white cams (A) and/or the grey plastoferrites (B).</p> <p>The white cams (A) always present identify the top and bottom stops. The presence of the others depends on machine options (intermediate stop, slowly at stop).</p>	
3	Put the mechanical stop (C) on the top rail near the top stop.	
4	<p>Check that the mechanical stop is in the correct direction.</p> <p>Note: This component provides additional safety in case of emergency.</p>	
5	Secure the mechanical stop by tightening the screws.	-

<p>6</p>	<p>Definitively fix the column of the top floor.</p>	
<p>7</p>	<p>Sometimes the mechanical stop can also be present at the low stop. In this case proceed as described above.</p>	<p>-</p>

SHEET	OPERATION DESCRIPTION					
INS-SUP-20	ADJUSTMENT OF LOAD CONTROL DEVICE (OPTIONAL)					
OPERATORS INVOLVED	2					
TIME REQUIRED (minutes)	20					
NECESSARY PPE						
				DIFFICULTY LEVEL		
						
RECOMMENDED EQUIPMENT						
<ul style="list-style-type: none"> ▪ 3mm Allen wrench ▪ 7mm hex wrench 						

This device keeps the machine from starting when the platform load is beyond a certain value (only at stops).

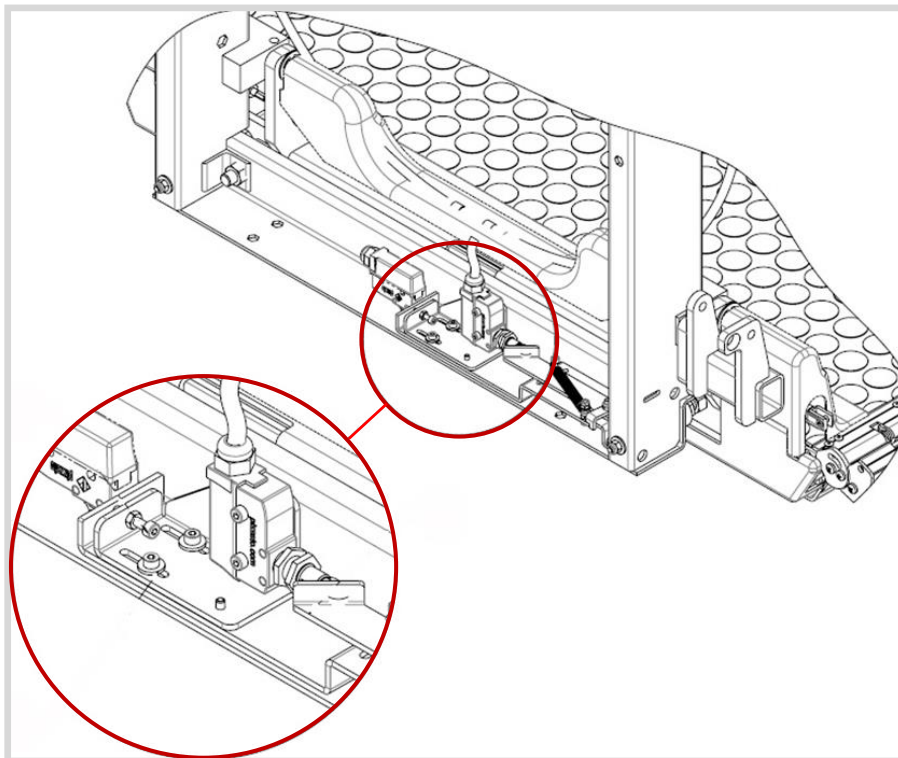

IMPORTANT!

It can be calibrated by applying a weight equal to the nominal capacity plus a 25% overload on the platform. The device was designed to meet regulatory specifications. Therefore different calibrations might not always be possible.







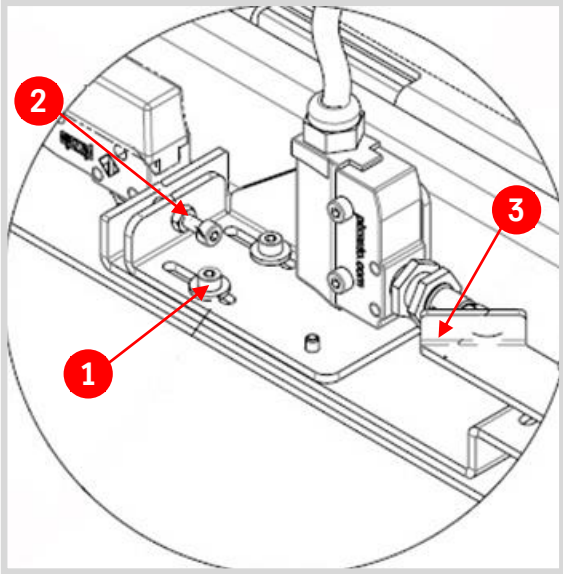

IMPORTANT!

The choice of the type and number of Belleville washers is made in the factory based on machine configuration. Therefore different calibrations than those intended when placing the order might not be available.







To adjust the platform, proceed as follows:

STAGE	DESCRIPTION	IMAGE
1	Loosen the fixing screw (1).	
2	Act on the adjusting screw (2) until the lever (3) causes the microswitch to trigger.	
3	Re-clamp the fixing screw (1).	

SHEET	OPERATION DESCRIPTION	
INS-SUP-21	INSTALLATION OF REAR CARRIAGE CASINGS	
OPERATORS INVOLVED	1	
TIME REQUIRED (minutes)	5	
NECESSARY PPE		
		
	DIFFICULTY LEVEL	
		
RECOMMENDED EQUIPMENT		
<ul style="list-style-type: none"> PH 3 screwdriver 		

To install the rear carriage casings, proceed as follows:

STAGE	DESCRIPTION	IMAGE
1	Set the casing on the carriage.	
2	Secure the casing using the screws supplied with the machine.	

SHEET	OPERATION DESCRIPTION					
INS-SUP-22	ASSEMBLY OF CASINGS					
OPERATORS INVOLVED	1					
TIME REQUIRED (minutes)	20					
NECESSARY PPE						
				DIFFICULTY LEVEL		
						
RECOMMENDED EQUIPMENT						
<ul style="list-style-type: none"> ▪ PH 3 screwdriver ▪ 13mm hex wrench 						









IMPORTANT!

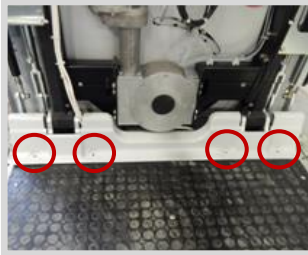



To couple the different casings, be careful not to damage the electric wiring and to respect the relative position of the components.

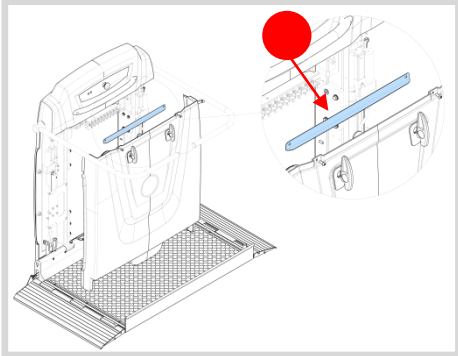
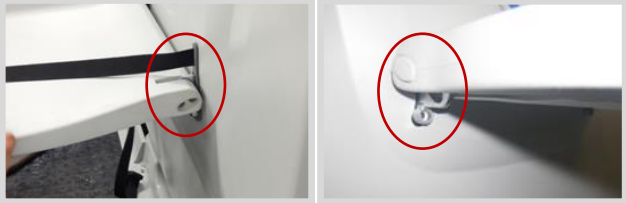



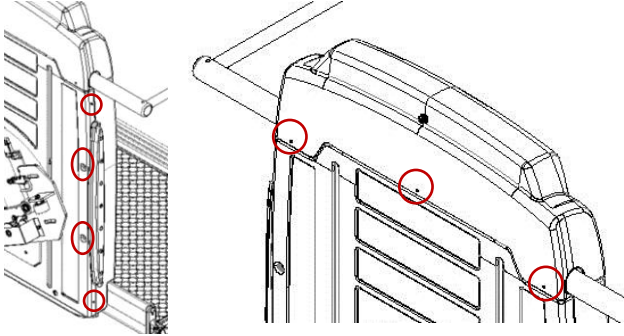

Some components, such as the seat, could be optional. Therefore the order of the steps cannot change.

To **mount the casings**, proceed as follows:

STAGE	DESCRIPTION	IMAGE
1	Secure the internal restraint casing with the specific screws.	 
2	Position the front casing on the platform without tightening it.	-
3	Insert the strap in the specific slots, both of the plate and of the front casing.	 



<p>4</p>	<p>Fasten the connector labelled “A”, coming from the front casing, to the machine board.</p>	
<p>5</p>	<p>Secure the support bar (A) at the top of the casing using the two screws.</p>	
<p>6</p>	<p>Insert the seat in the front casing by means of the specific slots and fix the brackets with the supplied screws.</p>	
<p>7</p>	<p>Fit the front casing on the rear casing without fixing it.</p>	
<p>8</p>	<p>Move the rubber rings on the safety bars outwards.</p>	







<p>9</p>	<p>Mount the top cover.</p>	
<p>10</p>	<p>Fasten the handle (B) to the cover.</p>	
<p>11</p>	<p>Proceed fixing the casings using the specific screws. Note: Apply the screws in the correct positions and check that the casings are coupled stably.</p>	
<p>12</p>	<p>Apply the manufacturer's sticker below the seat.</p>	

SHEET	OPERATION DESCRIPTION					
INS-SUP-23	INSTALLATION OF CALL DEVICES					
OPERATORS INVOLVED	1					
TIME REQUIRED (minutes)	20					
NECESSARY PPE						
				DIFFICULTY LEVEL		
						
RECOMMENDED EQUIPMENT						
<ul style="list-style-type: none"> ▪ PH3 screwdriver ▪ Ballpoint pen ▪ Small plastic flat-head screwdriver ▪ Drill ▪ Masonry bit 						

The machine is equipped with one or more radio call devices with a single sticker for upper, lower floor or intermediate stop.

To **install the call boxes**, proceed as follows:

STAGE	DESCRIPTION	IMAGE
1	Read the sticker below the box and identify the installation position (top, bottom, intermediate).	
2	If necessary, set a different radio channel (see chapter 5).	
3	Fix the call boxes to the wall with the supplied plugs.	-

SHEET	OPERATION DESCRIPTION					
INS-SUP-24	MAKING THE FIRST RUN					
OPERATORS INVOLVED	2					
TIME REQUIRED (minutes)	20					
NECESSARY PPE						
				DIFFICULTY LEVEL		
						
RECOMMENDED EQUIPMENT						
▪ Tube of grease						
LEVEL OF CRITICALITY						
▪ HIGH						



**CAUTION!**

Performing these operations incorrectly would jeopardise final installation of the machine. Therefore you must pay the utmost attention in carrying out the procedures described below.

**IMPORTANT!**

Proceed with caution on bends in the initial passages of the machine.

To drive the machine the first time, proceed as follows:

STAGE	DESCRIPTION	IMAGE
1	<p>Grease the rack and pinion on each bend.</p> <p>Note: Repeat this operation until the machine, in no-load conditions, runs regularly.</p> <p> CAUTION! During this phase, the safety disk (A) could be damaged due to the phenomenon described indicating that insufficient weight is applied to the platform.</p>	
2	Load the machine with a weight approximately half the nominal load (1-2 persons).	-
3	Perform a few passages (up and down) at each bend; this is necessary for the pinion to adapt the rack teeth to its passage.	-

4	In particular check the ascent manoeuvre as the pinion tends to move away from the rack during this phase.	-
5	If necessary repeat these operations several times until the machine, in no-load conditions, proceeds normally without the pinion tending to come out of the guide.	-

**SAFETY! CAUTION!**

Before having the machine perform a complete run, make sure that the safety devices work properly and the area is clear of obstacles or people.

3.2. PROCEDURES FOR FINAL CHECKS



IMPORTANT!

Before releasing the machine, all the checks indicated in the following end-of-installation list must be carried out. The test list included in the customer user manual must be filled out and signed by the installer.



IMPORTANT!

Failure to execute the final tests can jeopardise operation of the system and warranty terms and conditions.

A specific sheet describes the operations and procedures required to complete every stage.

Each table refers to the control of the different components of the machine.

STAGE	OPERATION DESCRIPTION	ASSEMBLY SHEET OF REFERENCE
1	GUIDES AND ANCHORINGS TESTS	CONTR-SUP-01
2	FLAPS TESTS	CONTR-SUP-02
3	SAFETY BARS TESTS	CONTR-SUP-03
4	PARACHUTE TESTS	CONTR-SUP-04
5	FUNCTIONAL CHECKS	CONTR-SUP-06
6	MANUAL EMERGENCY MANOEUVRE CHECKS	CONTR-SUP-07

Perform the checks and fully fill out the sheet.

REFERENCE	TEST	RESULT		VALUE
		POSITIVE	NEGATIVE	
1	GUIDES AND ANCHORINGS TESTS <ul style="list-style-type: none"> • Maximum guide rotation in degrees (°) • Guide residual deformation (mm) 	<input type="checkbox"/>	<input type="checkbox"/>	
		<input type="checkbox"/>	<input type="checkbox"/>	
2	FLAPS TESTS <ul style="list-style-type: none"> • Flap deformed under load (mm) 	<input type="checkbox"/>	<input type="checkbox"/>	
		<input type="checkbox"/>	<input type="checkbox"/>	
3	SAFETY BARS TESTS <ul style="list-style-type: none"> • Deformed under vertical load (mm) • Deformed under horizontal load (mm) 	<input type="checkbox"/>	<input type="checkbox"/>	
		<input type="checkbox"/>	<input type="checkbox"/>	
4	PARACHUTE TESTS	<input type="checkbox"/>	<input type="checkbox"/>	
6	FUNCTIONAL CHECKS <ul style="list-style-type: none"> • PHASE 1 • PHASE 2 • PHASE 3 	<input type="checkbox"/>	<input type="checkbox"/>	
		<input type="checkbox"/>	<input type="checkbox"/>	
		<input type="checkbox"/>	<input type="checkbox"/>	
		<input type="checkbox"/>	<input type="checkbox"/>	
7	MANUAL EMERGENCY MANOEUVRE PROJECTS	<input type="checkbox"/>	<input type="checkbox"/>	

NOTES







SYSTEM SERIAL NUMBER

DATE

INSTALLATION COMPANY

SIGNATURE







--	--	--	--

SHEET	OPERATION DESCRIPTION					
CONTR-SUP-01	GUIDES AND ANCHORINGS TESTS					
OPERATORS INVOLVED	1					
TIME REQUIRED (minutes)	30					
NECESSARY PPE						
				DIFFICULTY LEVEL		
						
RECOMMENDED EQUIPMENT						
<ul style="list-style-type: none"> ▪ Tape measure ▪ Weights 						

The tests on the guides verify rigidity in normal use and resistance to the stress caused by the safety devices. The guide must be able to pass the rigidity test at any point.

To perform **the guides and anchorings test**, proceed as follows:







STAGE	DESCRIPTION
1	Move the machine away from where the test must be conducted.
2	Check the position of the guide in the vertical plane.
3	Load the device to capacity, equally distributing the load on the platform.
4	Check that maximum rotation of the guide is no greater than 2° respect to the horizontal plane.
5	Discharge the platform and move the machine away.
6	Check that the guide has returned to the original position with a 2mm tolerance (residual deformation).
7	Check the integrity of the anchorings and bolted junctions of the parts making up the guide and fixing elements.

SHEET	OPERATION DESCRIPTION					
CONTR-SUP-02	FLAPS TESTS					
OPERATORS INVOLVED	1					
TIME REQUIRED (minutes)	10					
NECESSARY PPE						
				DIFFICULTY LEVEL		
						
RECOMMENDED EQUIPMENT						
<ul style="list-style-type: none"> ▪ Tape measure ▪ Spring dynamometer 						

The test is conducted in the factory. In case of subsequent "on site" adjustments, proceed as follows.

To perform the **flaps test**, proceed as follows:







STAGE	DESCRIPTION
1	Raise the flap.
2	Apply a 150N force to the end of the flap, perpendicular to the surface of the flap, applied in the opening direction.
3	Check that no part of the flap is deformed beyond 30mm (flap deformed under load).
4	Remove the force and check that there is no permanent deformation and check functioning.

SHEET	OPERATION DESCRIPTION					
CONTR-SUP-03	SAFETY BARS TESTS					
OPERATORS INVOLVED	1					
TIME REQUIRED (minutes)	20					
NECESSARY PPE						
				DIFFICULTY LEVEL		
						
RECOMMENDED EQUIPMENT						
<ul style="list-style-type: none"> ▪ Tape measure ▪ Spring dynamometer 						

The test is conducted in the factory. In case of subsequent "on site" adjustments, proceed as follows.

To perform the **safety bars test**, proceed as follows:

STAGE	DESCRIPTION
1	Place the bar in the safety position.
2	Apply a 100N force on the end of the bar in vertical direction (downward) on the longest side (before the start of the "L"-shaped bend).
3	Check that no point of the bar is deformed beyond 50mm (deformed under vertical load).
4	Remove the force and apply it in the horizontal direction (direction of the side opposite the guide) (just after the start of the "L"-shaped bend).
5	Check that it is deformed less than 50mm (deformed under horizontal load).
6	Check that there are no plastic deformation residues.
7	Check functioning of the bar.

SHEET	OPERATION DESCRIPTION
CONTR-SUP-04	PARACHUTE TESTS
OPERATORS INVOLVED	1
TIME REQUIRED (minutes)	10
NECESSARY PPE	
	
	
DIFFICULTY LEVEL	
	
	
RECOMMENDED EQUIPMENT	
<ul style="list-style-type: none"> ▪ 8mm socket wrench 	
LEVEL OF CRITICALITY	
<ul style="list-style-type: none"> ▪ HIGH 	

**CAUTION!**

Performing these operations incorrectly would jeopardise final installation of the machine. Therefore you must pay the utmost attention in carrying out the procedures described below.

**IMPORTANT!**



In at least one section of the guide, safely perform a practical test of triggering of the speed limiter and parachute, engaging the device manually.

**IMPORTANT!**

Perform the test with the platform open and in no-load conditions.

To perform the parachute test engaging the device manually, proceed as follows:

STAGE	DESCRIPTION	IMAGE
1	Move Supra to a straight section and remove the rear cover of the parachute using the hex wrench.	

<p>2</p>	<p>Turn the eccentric through the two brass columns to move the brake unit away from the rail.</p>	
<p>3</p>	<p>Quickly turn the parachute wheel in the downward direction to trigger the parachute mechanically.</p>	
<p>4</p>	<p>Restore the initial conditions and refit the cover. Check that the lift works properly moving up and down.</p>	<p>-</p>







SHEET	OPERATION DESCRIPTION
CONTR-SUP-05	FUNCTIONAL CHECKS

OPERATORS INVOLVED	1
--------------------	---

TIME REQUIRED (minutes)	20
-------------------------	----

NECESSARY PPE				DIFFICULTY LEVEL		
						

STAGE	DESCRIPTION
1	Check that the machine works correctly by giving commands from the devices on the floor, on board and from any auxiliary devices (wire control and/or radio control) in compliance with that described in the USER manual.
2	Check that the safety devices work properly in compliance with that described in the user manual.
3	Check that the stopping distance of the lift is within the specification limits: <ul style="list-style-type: none"> ▪ Max. 20 mm if following triggering of a safety device ▪ Max. 50 mm if following interruption of a run command

SHEET	OPERATION DESCRIPTION					
CONTR-SUP-06	MANUAL EMERGENCY MANOEUVRE PROJECTS					
OPERATORS INVOLVED	1					
TIME REQUIRED (minutes)	20					
NECESSARY PPE						
				DIFFICULTY LEVEL		
						
RECOMMENDED EQUIPMENT						
<ul style="list-style-type: none"> ▪ Handwheel 						

Insert the handwheel in the inlet on the front casing and turn it in the desired running direction checking that the symbols on the accessory and the actual drive direction correspond.

STAGE	DESCRIPTION
1	Insert the handwheel in the inlet on the front casing and turn it in the desired running direction checking that the symbols on the accessory and the actual drive direction correspond.

[PAGE INTENTIONALLY LEFT BLANK]

[PAGE INTENTIONALLY LEFT BLANK]

4. MECHANICAL ADJUSTMENTS

Perform the operations indicated in the tables, following the same order, to adjust the mechanical components. A specific sheet describes the operations and procedures required to complete every stage.

Every table describes the adjustment procedure for the various components.

STAGE	OPERATION DESCRIPTION	ADJUSTMENT PROCEDURE SHEET
1	ADJUSTMENT OF ELECTROMECHANICAL TILTING CLUTCH OF THE PLATFORM (REM)	REG M-SUP-01
2	ADJUSTMENT OF SIDE FLAPS	REG M-SUP-02
3	ADJUSTMENT OF SAFETY BARS INCLINATION	REG M-SUP-03
4	ADJUSTMENT OF SAFETY BARS CLUTCH (REB)	REG M-SUP-04

SHEET	OPERATION DESCRIPTION
REG M-SUP-01	ADJUSTMENT OF ELECTROMECHANICAL TILTING CLUTCH OF THE PLATFORM (REM)
OPERATORS INVOLVED	1
TIME REQUIRED (minutes)	5
NECESSARY PPE	
DIFFICULTY LEVEL	
RECOMMENDED EQUIPMENT	
<ul style="list-style-type: none"> ▪ 2 13mm hex wrenches 	

The function of the clutch is to allow the platform to open and close, avoiding overloads.



IMPORTANT!

The clutch must be able to slip a few millimetres to guarantee correct opening and closing of the platform.

To adjust the electromechanical tilting clutch (REM), proceed as follows:





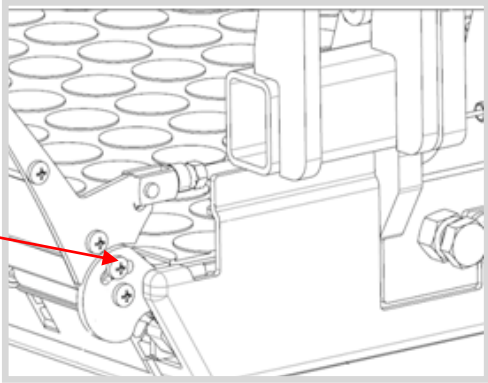

STAGE	DESCRIPTION	IMAGE
1	Perform an opening and closing cycle of the platform and check that movements are complete.	-
2	<p>If the platform does not open and close correctly, screw or unscrew the nut (A) turning it 1/4 at a time according to the adjustment to be made.</p> <p>Note: If the nut is tightened too much the clutch would not be able to slip, causing the actuator to overload.</p>	

SHEET	OPERATION DESCRIPTION
REG M-SUP-02	ADJUSTMENT OF SIDE FLAPS
OPERATORS INVOLVED	1
TIME REQUIRED (minutes)	5
NECESSARY PPE	
DIFFICULTY LEVEL	
RECOMMENDED EQUIPMENT	
<ul style="list-style-type: none"> ▪ 10mm hex wrench ▪ 12mm hex wrench ▪ 13mm hex wrench 	

To adjust the **position of the flaps**, proceed as follows:

STAGE	DESCRIPTION	IMAGE
1	Act on the registers (1) and (2).	
2	Act on the register (3).	

3	<p>Adjust the safety function by moving the flap up (run condition) and act on the adjustment cam (4): the flap must engage the microswitch after striking an obstacle or forcing opening.</p>	
4	<p>After having made the adjustments, check functioning of the stops (correct landing) and triggering of the anti-shock safety device both with the platform open and closed.</p>	

SHEET	OPERATION DESCRIPTION					
REG M-SUP-03	ADJUSTMENT OF SAFETY BARS INCLINATION					
OPERATORS INVOLVED	1					
TIME REQUIRED (minutes)	10					
NECESSARY PPE						
				DIFFICULTY LEVEL		
						
RECOMMENDED EQUIPMENT						
<ul style="list-style-type: none"> Pin punch Ø 4 mm 2 13mm hex wrenches 						





IMPORTANT!

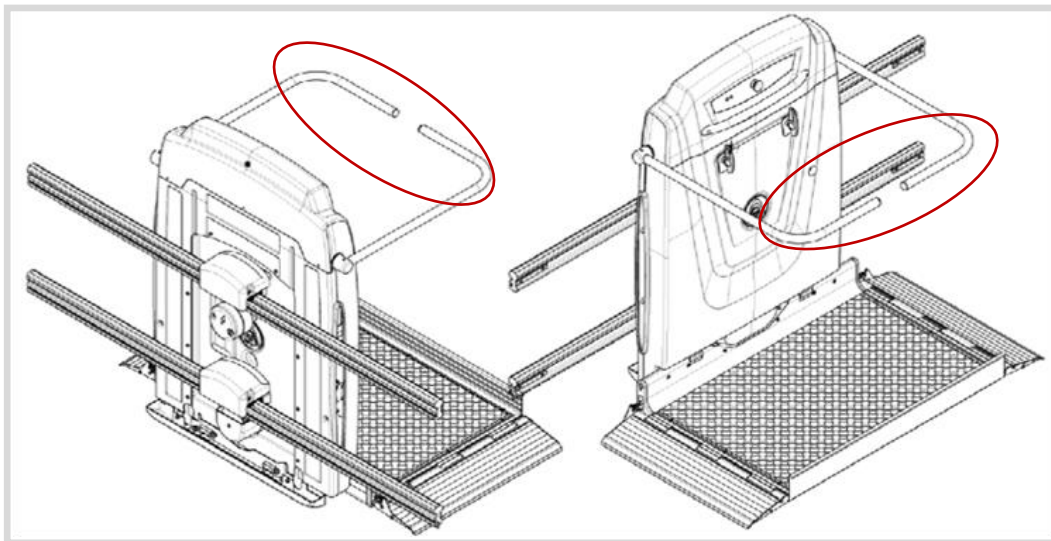

The exact adjustment is achieved when the safety bars are aligned one with another, with an upward inclination angle of 1° or 2°.

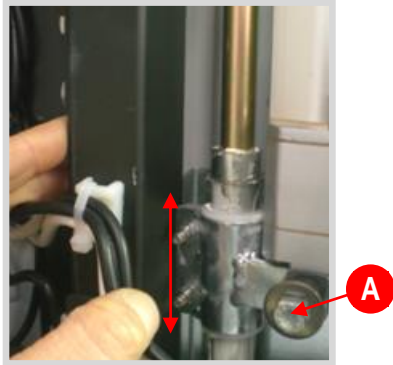

To adjust the **position of the safety bars**, proceed as follows:

STAGE	DESCRIPTION	IMAGE
1	Check that the rod of the actuator is at zero stroke.	

<p>2</p>	<p>Loosen the screw (A) of the clutch so that the actuator slides freely on the rod.</p>	
<p>3</p>	<p>Loosen the ring nuts (B) to bring the bars to the correct inclination (1° or 2° upward).</p>	
<p>4</p>	<p>Tighten the ring nuts with a punch pin when the adjustment is over.</p>	

SHEET	OPERATION DESCRIPTION
REG M-SUP-04	ADJUSTMENT OF SAFETY BARS CLUTCH (REB)
OPERATORS INVOLVED	1
TIME REQUIRED (minutes)	20
NECESSARY PPE	
	
DIFFICULTY LEVEL	
	
RECOMMENDED EQUIPMENT	
<ul style="list-style-type: none"> ▪ 2 13mm hex wrenches 	

The function of the clutch is to allow the safety bars to open and close, avoiding overloads of the actuator.





IMPORTANT!
Adjust one safety bar at a time.

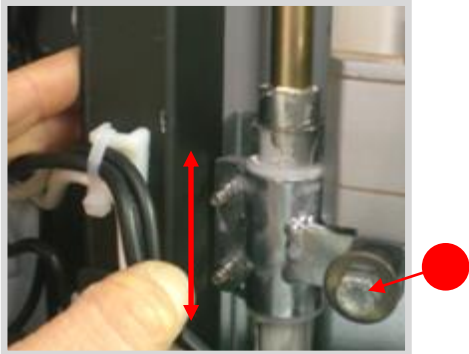

IMPORTANT!
Clutch adjustment must be checked after having mounted all the casings of the machine.

To adjust the electromechanical tilting clutch (REB), proceed as follows:

STAGE	DESCRIPTION	IMAGE
1	Completely loosen the screw (A) and then tighten it as much as necessary to allow the actuator to move the bar.	
2	Open the bar and register the stop of the actuator.	

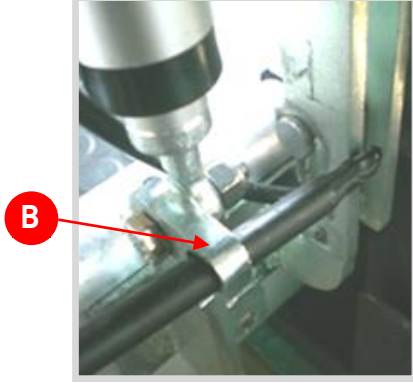
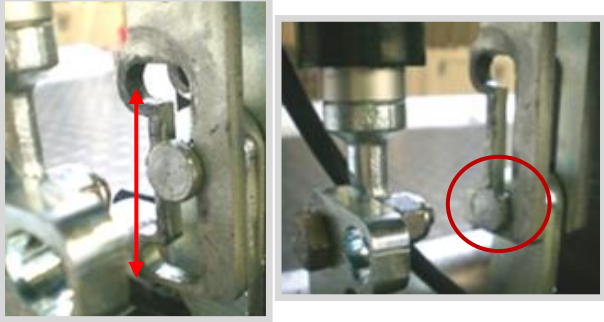
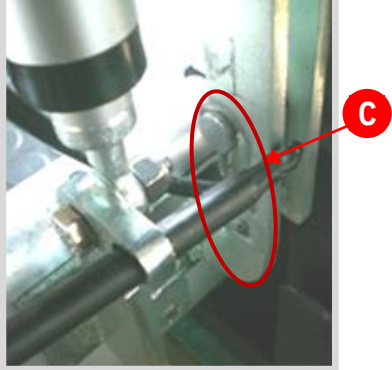
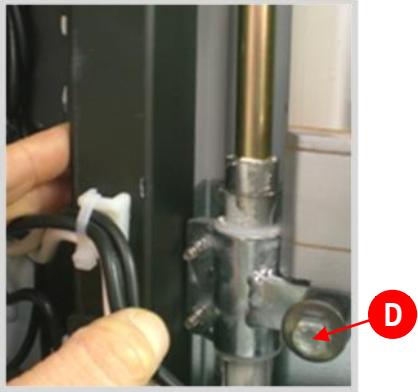
3	Check that the bar release system works properly by inserting the supplied handwheel in the specific housing (B).	
4	Release the lever, simultaneously lifting the safety bar until it stops at the upper position. Note: Act on the upper stop of the actuator, increasing the upward stroke, until the lever reaches the upper block position.	
5	Restore the operating configuration (C) by inverting the procedure.	
6	Have the safety bar perform a series of movements.	-
7	If the bar does not move correctly, because the clutch slips too far, you must tighten the screw (D) turning it 1/4 at a time. Note: The actuator stroke is beyond that allowed by the lever. It is normal for the clutch to slip a few mm and this must always occur. If the clutch does not slip, loosen it all the way and adjust it again.	

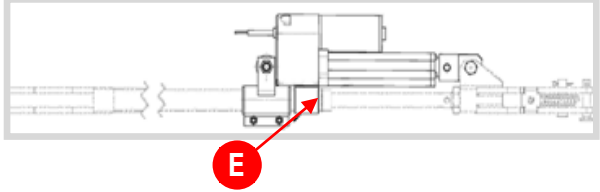
<p>8</p>	<p>In some cases a spacer (E) can be used on the lever.</p>	
<p>9</p>	<p>Repeat all the steps for the other safety bar.</p>	<p>-</p>

[PAGE INTENTIONALLY LEFT BLANK]

5. ELECTRICAL/ELECTRONIC ADJUSTMENTS

5.1. ELECTRICAL/ELECTRONIC ADJUSTMENT PROCEDURES

Perform the operations indicated in the tables, following the same order, to adjust the electrical devices. A specific sheet describes the operations and procedures required to complete every stage.





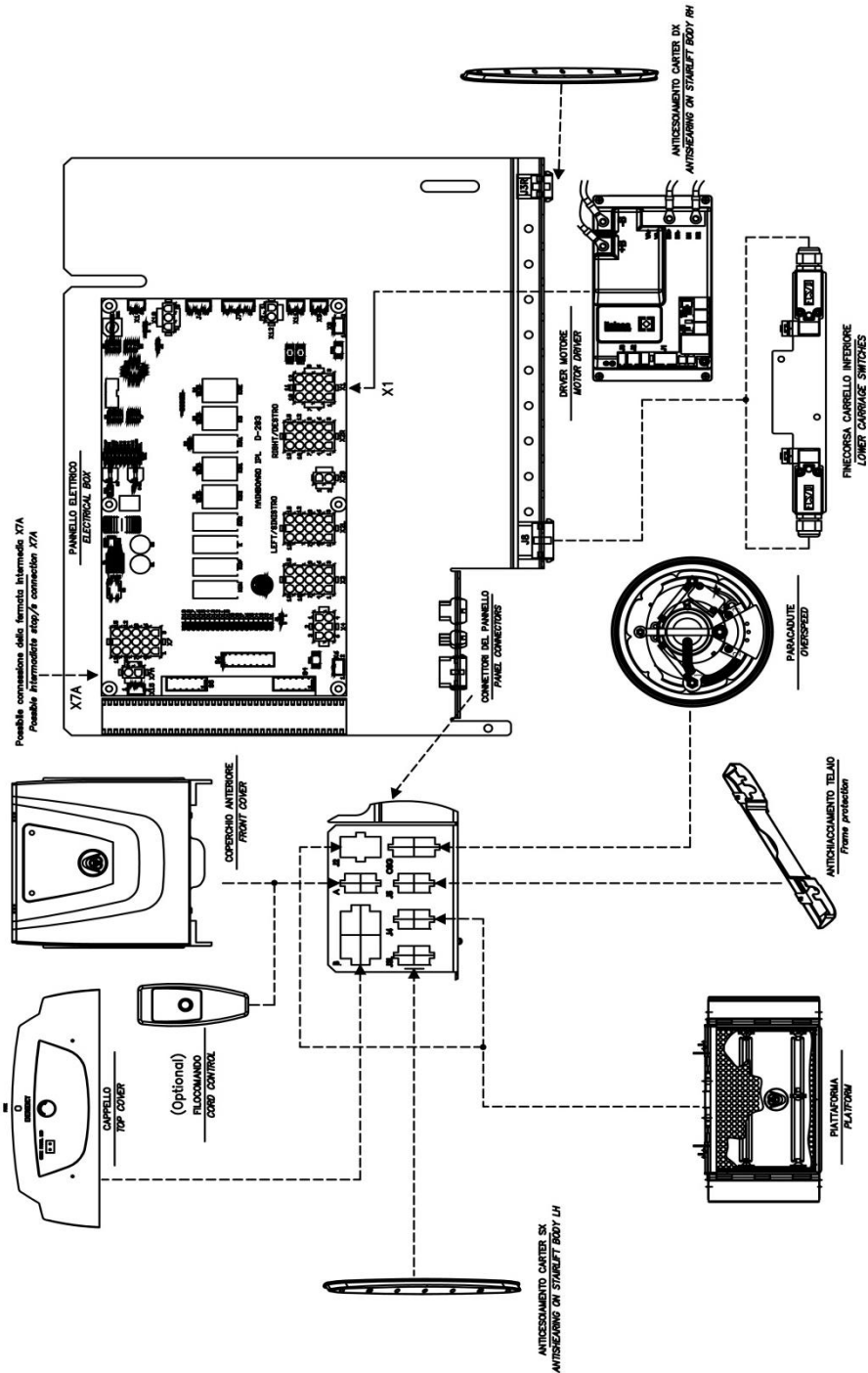

Every table describes the adjustment procedure for the various devices.

STAGE	OPERATION DESCRIPTION	ADJUSTMENT PROCEDURE SHEET
1	ELECTRICAL CONNECTIONS OVERVIEW	REG E-SUP-01
2	CONNECTION OF X2L AND X2R CONNECTORS	REG E-SUP-02
3	CONFIGURATIONS MADE WITH DIP SWITCHES	REG E-SUP-03
4	ENABLING THE SAFETY BARS ON THE BOTTOM FLOOR	REG E-SUP-04
5	ENABLING/DISABLING THE LOAD CELL	REG E-SUP-05
6	ENABLING/DISABLING THE ON/OFF SELECTOR ON THE CASING ON TOP OF THE MACHINE	REG E-SUP-06
7	LONG SIDE ACCESS (LSA) CONFIGURATIONS - DIP 8	REG E-SUP-07
8	RADIO CHANNEL SETTING	REG E-SUP-08
9	CALIBRATION OF THE TRANSMISSION DISTANCE (OPTIONAL)	REG E-SUP-09
10	ADJUSTMENT OF THE BRUSHES	REG E-SUP-10
11	CHOPPER ADJUSTMENTS	REG E-SUP-11
12	CALL DEVICES - CONFIGURATION	REG E-SUP-12
13	CALL BOXES WITH JOYSTICK AND RADIO CONTROL - CONFIGURATION	REG E-SUP-13
14	CALL DEVICES - TRANSMISSION POWER SETTING	REG E-SUP-14



IMPORTANT!

It is good practice to comply with the machine's wiring diagram to perform this type of adjustment.

SHEET	OPERATION DESCRIPTION
REG E-SUP-02	CONNECTION OF X2L AND X2R CONNECTORS
OPERATORS INVOLVED	1
TIME REQUIRED (minutes)	1
NECESSARY PPE	
	
	
DIFFICULTY LEVEL	
	
	







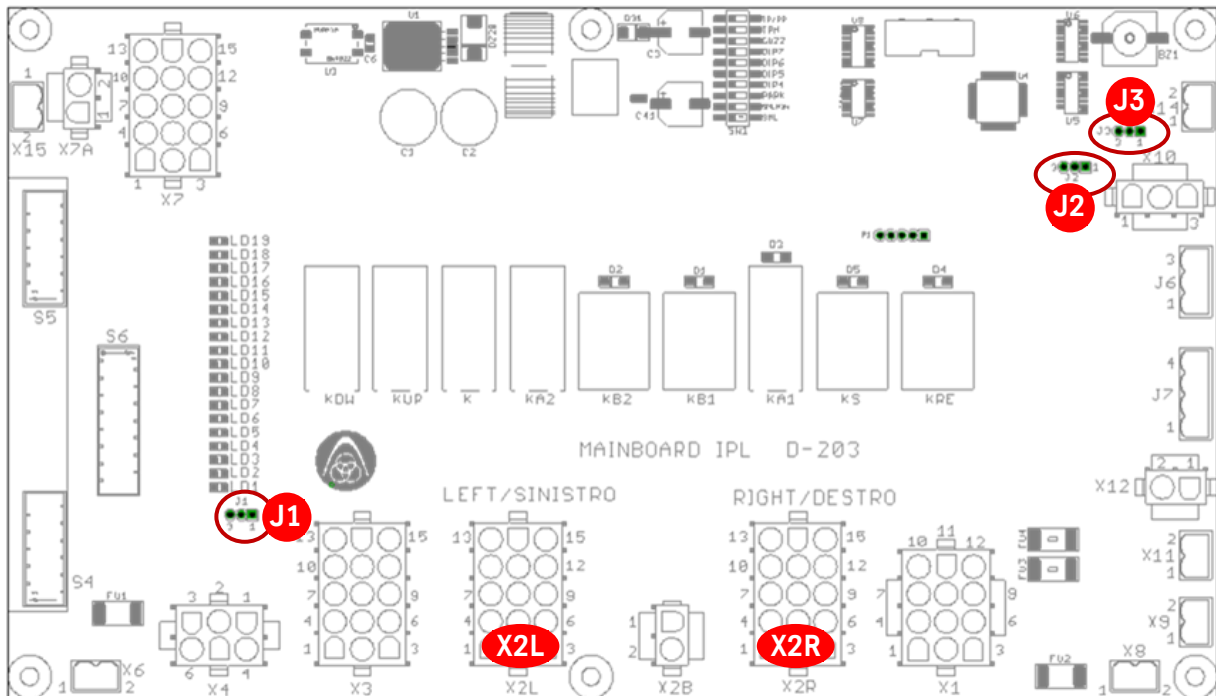

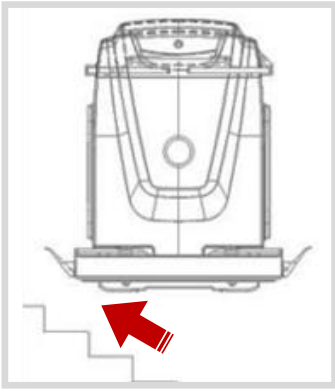
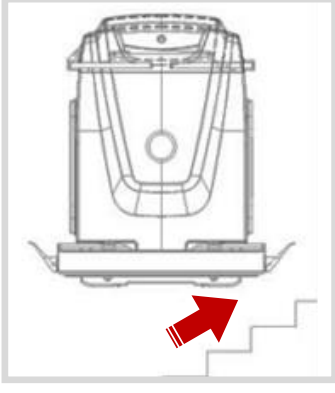

IMPORTANT!

These connectors are positioned on the Mainboard and allow you to configure the machine's safety devices according to the type of installation (right or left).



Proceed as follows to connect the connectors:

STAGE	DESCRIPTION	IMAGE
1	With machine on the right, insert male connector X2 into X2R on the board.	
2	With machine on the left, insert male connector X2 into X2L on the board.	







SHEET	OPERATION DESCRIPTION
REG E-SUP-03	CONFIGURATIONS MADE WITH DIP SWITCHES
OPERATORS INVOLVED	1
TIME REQUIRED (minutes)	-
NECESSARY PPE	
	
	
DIFFICULTY LEVEL	
	
	
RECOMMENDED EQUIPMENT	
<ul style="list-style-type: none"> ▪ Ballpoint pen ▪ Small plastic flat-head screwdriver 	

**IMPORTANT!**

The configurations made with dip switches vary according to the machine model.

The configurations that can be made with dip switches are indicated in the table (dip switches from 4 to 7 are not used).

CONFIGURATION	MODEL	DESCRIPTION	DIP ON
SML	TP/RPSP	LONG SIDE ACCESS ENABLED	1
SML MIN	TP/RPSP	MINIMUM OVERALL DIMENSIONS FOR ENABLED LONG SIDE ACCESS (DIP 1 MUST BE ENABLED)	1 + 2
PARK	TP	PARK FUNCTION ENABLED (SAFETY BARS CLOSED)	3
BUZZ	TP/RPSP	MODIFIES THE FLAP RECOVERY TIME AFTER PLATFORM CLOSURE	8
TPH	TP	FAST TP MACHINE (DECELERATION MANAGEMENT)	9 + 10
TP/RPSP	TP/RPSP	TP/RPSP IDENTIFICATION (DIFFERENT START-UP DELAY MANAGEMENT)	10

SHEET	OPERATION DESCRIPTION					
REG E-SUP-04	ENABLING THE SAFETY BARS ON THE BOTTOM FLOOR					
OPERATORS INVOLVED	1					
TIME REQUIRED (minutes)	1					
NECESSARY PPE						
					DIFFICULTY LEVEL	
						

Refer to the image on the previous pages to locate the specific Jumper.

Proceed as follows to **open the bars**:

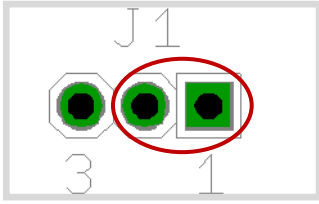
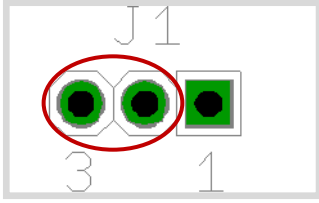





STAGE	DESCRIPTION	IMAGE
1	Insert Jumper J1 on the right (PIN 1-2) to open the bar on the descent side.	
2	Insert Jumper J1 on the left (PIN 2-3) to open both bars.	

SHEET	OPERATION DESCRIPTION
REG E-SUP-05	ENABLING/DISABLING THE LOAD CELL
OPERATORS INVOLVED	1
TIME REQUIRED (minutes)	1
NECESSARY PPE	
DIFFICULTY LEVEL	

Refer to the image on the previous pages to locate the specific Jumper.

Proceed as follows to **enable or disable the load cell**:





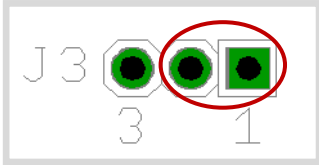
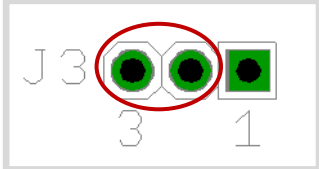

STAGE	DESCRIPTION	IMAGE
1	Insert Jumper J2 on the right (PIN 1-2) to enable the load cell.	
2	Insert Jumper J2 on the left (PIN 2-3) to disable the load cell.	

SHEET	OPERATION DESCRIPTION
REG E-SUP-06	ENABLING/DISABLING THE ON/OFF SELECTOR ON THE CASING ON TOP OF THE MACHINE
INVOLVED OPERATORS	1
TIME REQUIRED (minutes)	1
NECESSARY PPE	
	
	
DIFFICULTY LEVEL	
	
	

Refer to the image on the previous pages to locate the specific Jumper.

Proceed as follows to **enable** or **disable** the selector:

STAGE	DESCRIPTION	IMAGE
1	Insert Jumper J3 on the right (PIN 1-2) to enable the selector.	
2	Insert Jumper J3 on the left (PIN 2-3) to disable the selector.	

SHEET	OPERATION DESCRIPTION					
REG E-SUP-07	LONG SIDE ACCESS CONFIGURATIONS (MSC) - DIP 8					
OPERATORS INVOLVED	1					
TIME REQUIRED (minutes)	5					
NECESSARY PPE						
						
RECOMMENDED EQUIPMENT						
<ul style="list-style-type: none"> ▪ Ballpoint pen ▪ Small plastic flat-head screwdriver 						

**CAUTION!**

The machine comes already configured. Change the factory configuration only if required, considering all the possible risks that may arise. When in doubt, contact the manufacturer.

**CAUTION!**

Use the insulating mat to perform operations and verifications on the live electrical panel.

The platform long access (optional) allows side access to the bottom floor. When the platform closes, the side appendix opens completely and it is partially recalled during the final stage to reduce the clearance on the stairs.

The flap recall time is adjusted in the factory before shipment. If required, it can be set differently during the installation stage.

Adjustment is carried out via DIP 8 "BUZZ" on the motherboard.

Proceed as follows to **configure the long side access with DIP 8**:

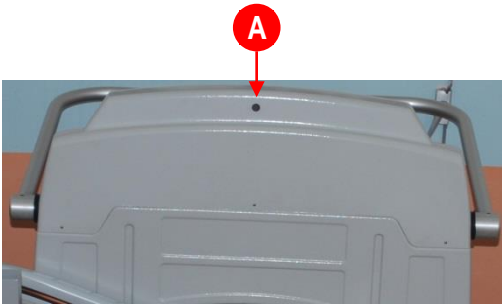
STAGE	DESCRIPTION	IMAGE
1	Loosen the fuse carrier on the casing (A) or disconnect the electrical panel and wait for the LEDs to switch off.	
2	Switch DIP 8 to ON	-

3	Restore power supply.	-
4	The board will sound to indicate that the programming mode is enabled.	-
5	Switch DIP 8 to OFF and then to ON. Note: The board emits a sound upon every variation to signal that the command has been acknowledged. The board emits a number of consecutive beeps to indicate the delay time set (1 beep = 100 ms) compared to the standard interval.	-
6	Repeat the operation in succession to increase the recovery time (10 steps of 100 ms).	-
7	Wait 5 seconds for the machine to repeat the saved number and emit a sound to indicate the programming mode exit.	-
8	Once the operation is complete, switch DIP 8 to OFF.	-

**IMPORTANT!**

After 5 seconds of inactivity, the board exits the programming mode automatically and emits a sound.

**IMPORTANT!**

Once the maximum recovery extra-time is reached, the count restarts from 1.

SHEET

OPERATION DESCRIPTION

REG E -SUP-08

RADIO CHANNEL SETTING

OPERATORS INVOLVED

1

TIME REQUIRED (minutes)

1

NECESSARY PPE

DIFFICULTY LEVEL

**IMPORTANT!**







The devices come already configured with the same channel. Therefore, channels should not be set unless there are other machines nearby.

**IMPORTANT!**

The frequencies used are public, therefore there could be other devices using the same frequencies.

Below is the table used to change the radio channel via dip switch (from 1 to 4). The same dip configuration must be set on the transmitters.

CHANNEL	FREQUENCY (Mhz)	DIP 1	DIP 2	DIP 3	DIP 4
1	433.150	OFF	OFF	OFF	OFF
2	433.250	ON	OFF	OFF	OFF
3	433.350	OFF	ON	OFF	OFF
4	433.450	ON	ON	OFF	OFF
5	433.550	OFF	OFF	ON	OFF
6	433.650	ON	OFF	ON	OFF
7	433.750	OFF	ON	ON	OFF
8	433.850	ON	ON	ON	OFF
9	433.950	OFF	OFF	OFF	ON
10	434.050	ON	OFF	OFF	ON
11	434.150	OFF	ON	OFF	ON
12	434.250	ON	ON	OFF	ON
13	434.350	OFF	OFF	ON	ON
14	434.450	ON	OFF	ON	ON
15	434.550	OFF	ON	ON	ON
16	434.650	ON	ON	ON	ON

SHEET	OPERATION DESCRIPTION		
REG E-SUP-09	CALIBRATION OF THE TRANSMISSION DISTANCE (OPTIONAL)		
OPERATORS INVOLVED	1		
TIME REQUIRED (minutes)	5		
NECESSARY PPE			
   	<th colspan="2">DIFFICULTY LEVEL</th>	DIFFICULTY LEVEL	
	  		
RECOMMENDED EQUIPMENT			
<ul style="list-style-type: none"> ▪ Ballpoint pen ▪ Small plastic flat-head screwdriver 			



IMPORTANT!

The radio receiver comes already configured. Apply modifications only if required and perform the following operations considering the possible risks that may arise.









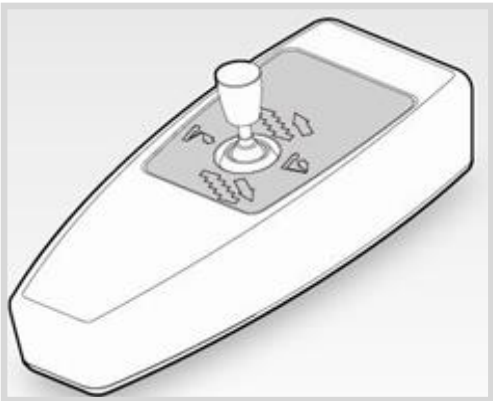
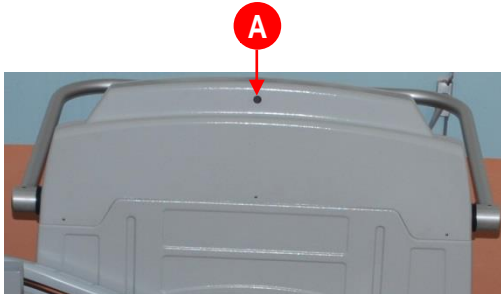

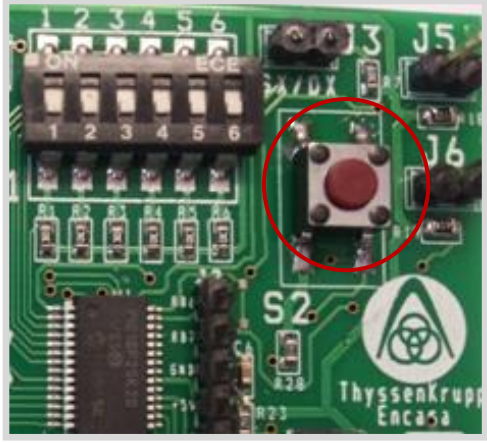
IMPORTANT!

The calibration distance must not expose the user to danger. The radio control must control the machine on board of it at such a distance to ensure the controller to view the path.

Proceed as follows to **calibrate the receiver**:

STAGE	DESCRIPTION	IMAGE
1	Insert the batteries in the radio control (TX module).	
2	Loosen the fuse carrier (A) on the casing or disconnect the electrical panel.	

3	Wait 5 seconds to be sure there is no power supply.	-
4	Restore power supply and press S2 on board the receiver within 3 seconds to switch all the LEDs on.	
5	<p>Move to the maximum distance required holding the portable radio device and press a command (up or down) for at least 5 seconds or until the LED on the casing on top of the machine starts flashing.</p> <p>The receiver LEDs will switch off as soon as calibration is complete.</p> <p>Note: If the radio control is set above its capacity, the green LED on the casing on top of the machine will start flashing, but the machine will not move.</p>	

SHEET	OPERATION DESCRIPTION	
REG E-SUP-10	ADJUSTMENT OF THE BRUSHES	
OPERATORS INVOLVED	1	
TIME REQUIRED (minutes)	20	
NECESSARY PPE		
		
	DIFFICULTY LEVEL	
		
RECOMMENDED EQUIPMENT		
<ul style="list-style-type: none"> ▪ 10mm socket wrench ▪ 2 13mm hex wrenches 	<ul style="list-style-type: none"> ▪ Rubber hammer 	







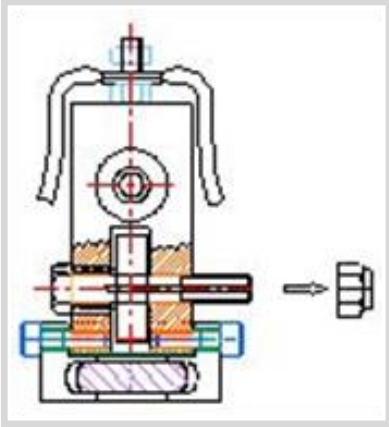

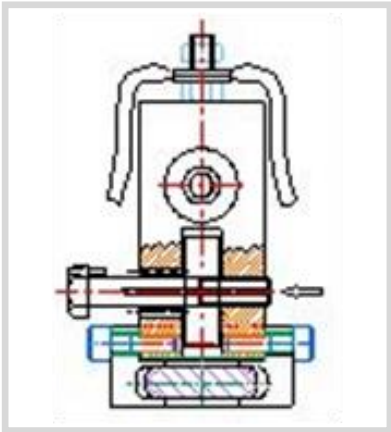
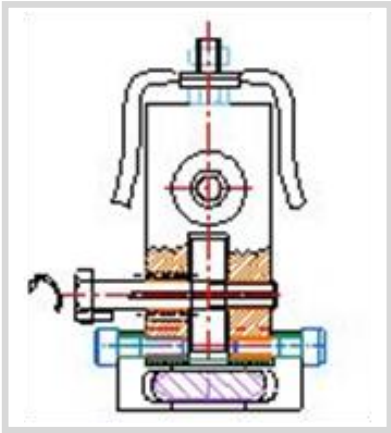
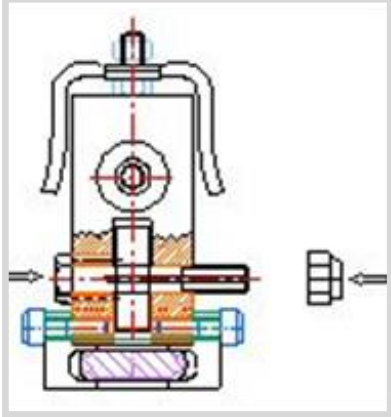
IMPORTANT!
Adjust the spring pre-charge when the brushes are excessively worn.

Proceed as follows to **adjust the brushes**:

STAGE	DESCRIPTION	IMAGE
1	Increase the spring pressure force if the copper brush does not contact the bus bar properly. Turn the screw that acts on the torsion spring on the brush.	
2	Remove the M8 self-locking nut.	

<p>3</p>	<p>Slightly loosen the M8 screw (do not remove).</p>	
<p>4</p>	<p>Turn the M8 screw until the pin is near a new hole.</p>	
<p>5</p>	<p>Insert the M8 screw in the plastic support and put the M8 self-locking nut on.</p>	
<p>6</p>	<p>Reposition and stop the brush supports to allow the brushes to touch the bottom of the bus bar.</p>	<p>-</p>

SHEET	OPERATION DESCRIPTION
REG E-SUP-11	CHOPPER ADJUSTMENTS
OPERATORS INVOLVED	1
TIME REQUIRED (minutes)	5
NECESSARY PPE	
	
	
DIFFICULTY LEVEL	
	
	
RECOMMENDED EQUIPMENT	
<ul style="list-style-type: none"> ▪ Ballpoint pen ▪ Small plastic flat-head screwdriver 	

**IMPORTANT!**

The machine comes already configured. Change the configurations below only when required and perform the following operations considering the risks that may arise.

The table below indicates the **chopper configuration trimmers and daps:**

LABEL	DESCRIPTION	FACTORY SETTINGS
DIP 1	TP with fast or slow motor	ON for fast machine OFF for slow machine
DIP 2	Down speed (OFF) Reduced speed (ON)	Down speed (OFF)
T1	Down speed Reduced speed (near a bend or landing)	At half run

SHEET	OPERATION DESCRIPTION
REG E-SUP-12	CALL DEVICES - CONFIGURATION

OPERATORS INVOLVED	1
--------------------	---

TIME REQUIRED (minutes)	10
-------------------------	----

NECESSARY PPE				DIFFICULTY LEVEL		
						

RECOMMENDED EQUIPMENT
<ul style="list-style-type: none"> ▪ Ballpoint pen ▪ Small plastic flat-head screwdriver ▪ PH 2 screwdriver

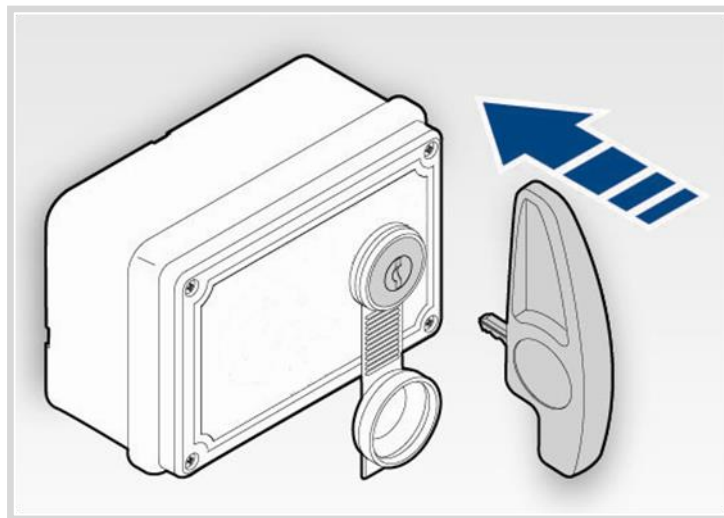







These calling devices are piloted by the radio receiver inside the machine. Make sure that the dip switches of the radio channels on the device boards are all set in the same way.

Below is the **jumper combination table** (jumper P/F is not used):

BOX	JUMPER CI	JUMPER A/B	JUMPER EMER
TOP FLOOR	NO	NO	YES
BOTTOM FLOOR	NO	YES	YES
INTERMEDIATE STOP	YES	NO	YES



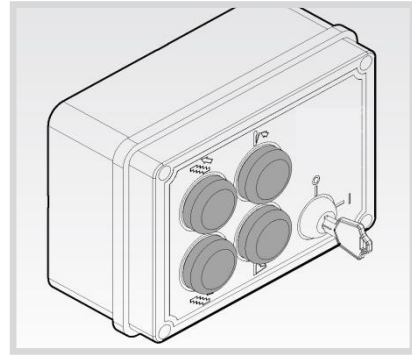
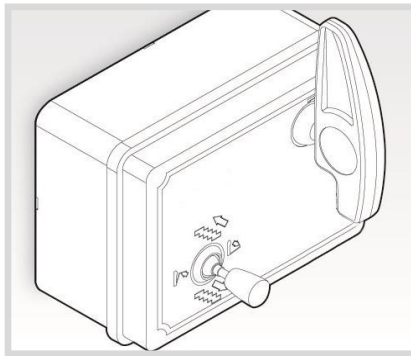
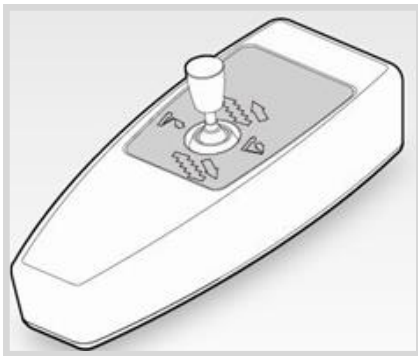

Jumper “EMER”: do not remove. It may be missing only in some markets

SHEET	OPERATION DESCRIPTION
REG E-SUP-13	CALL BOXES WITH JOYSTICK AND RADIO CONTROL - CONFIGURATION
OPERATORS INVOLVED	1
TIME REQUIRED (minutes)	10
NECESSARY PPE	
	
	
DIFFICULTY LEVEL	
	
	
RECOMMENDED EQUIPMENT	
<ul style="list-style-type: none"> ▪ Ballpoint pen ▪ Small plastic flat-head screwdriver 	<ul style="list-style-type: none"> ▪ PH 2 screwdriver



These calling devices are piloted by the radio receiver inside the machine. Make sure that the dip switches of the radio channels on the device boards are all set in the same way.

Below is the table of the **controls** available on the devices:

CONTROL	DESCRIPTION
	Up: This control enables the lift platform movement (both with platform open and closed).
	Down: This control enables the lift platform movement (both with platform open and closed).
	Opening: The lift platform is ready for the user to climb on it.
	Close: The lift platform is ready to be closed.







Below is the table for the **box jumper combination**:

BOX	JUMPER CI	JUMPER A/B	JUMPER P/F	JUMPER EMER
TOP FLOOR	NO	NO	YES	YES
BOTTOM FLOOR	NO	YES	YES	YES
INTERMEDIATE STOP	YES	NO	YES	YES

Below is the table of the **radio control jumper combination**:

BOX	JUMPER CI	JUMPER A/B	JUMPER P/F	JUMPER EMER
TOP FLOOR	NO	NO	NO	YES
BOTTOM FLOOR	NO	NO	NO	YES
INTERMEDIATE STOP	NO	NO	NO	YES

Jumper "EMER": do not remove. It may be missing only in some markets.

SHEET	OPERATION DESCRIPTION
REG E-SUP-14	CALL DEVICES - TRANSMISSION POWER SETTING
OPERATORS INVOLVED	1
TIME REQUIRED (minutes)	5
NECESSARY PPE	
	
	
DIFFICULTY LEVEL	
	
	
RECOMMENDED EQUIPMENT	
<ul style="list-style-type: none"> ▪ Ballpoint pen ▪ Small plastic flat-head screwdriver 	<ul style="list-style-type: none"> ▪ PH 2 screwdriver

Below is the table of the **transmission power for dips 6 and 7** (only on TX):

DIP 6	DIP 7	POWER
OFF	OFF	- 20 dbm
ON	OFF	-10 dbm
OFF	ON	0 dbm
ON	ON	+10 dbm

5.2. DESCRIPTION/OPERATION OF THE ELECTRICAL/ELECTRONIC DEVICES

This paragraph shows the descriptions/operations of some electrical and electronic components of the machine.

Each table refers to the description/operation of the components.

DESCRIPTION/OPERATION	ASSEMBLY SHEET OF REFERENCE
SUMMARY OF THE AUDIBLE WARNINGS	DESC/OP E-SUP-01
LED SIGNALS SUMMARY	DESC/OP E-SUP-02
RADIO RECEIVER FEATURES	DESC/OP E-SUP-03
BLOCK STATUS	DESC/OP E-SUP-04
TOP AND BOTTOM STOP OPERATION LOGIC	DESC/OP E-SUP-05
OPERATION LOGIC OF INTERMEDIATE STOPS AND DECELERATION NEAR BENDS	DESC/OP E-SUP-06
CHOPPER OUTPUT/INPUT CONNECTIONS	DESC/OP E-SUP-07
CHOPPER DIAGNOSTICS	DESC/OP E-SUP-08
BRAKE BOARD	DESC/OP E-SUP-09
SUMMARY OF THE RADIO CONTROL DEVICE FUNCTIONS (TRANSMITTERS)	DESC/OP E-SUP-10

SHEET	DESCRIPTION/OPERATION
DESC/OP E-SUP-01	SUMMARY OF THE AUDIBLE WARNINGS

Below is the description of the signals according to the buzzer beep.

BEEP	SIGNAL
200 ms ON, 200 ms OFF	ALARM (The lack of contact of the long side access triggers the alarm within 8 seconds)
200 ms ON, 200 ms OFF	LOAD CELL ENABLED WITH RUN REQUEST
300 ms ON, 300 ms OFF	NOT MATCHING (The alarm is triggered if there is a run request but authorisation is missing or if the machine is already at the floor)
400 ms ON, 400 ms OFF	MACHINE RUNNING
800 ms ON, 800 ms OFF	LOAD CELL ENABLED WITHOUT RUN REQUEST

SHEET

DESCRIPTION/OPERATION

DESC/OP E-SUP-02

LED SIGNALS SUMMARY

The Mainboard is equipped with LEDs indicating the status of the lift platform.

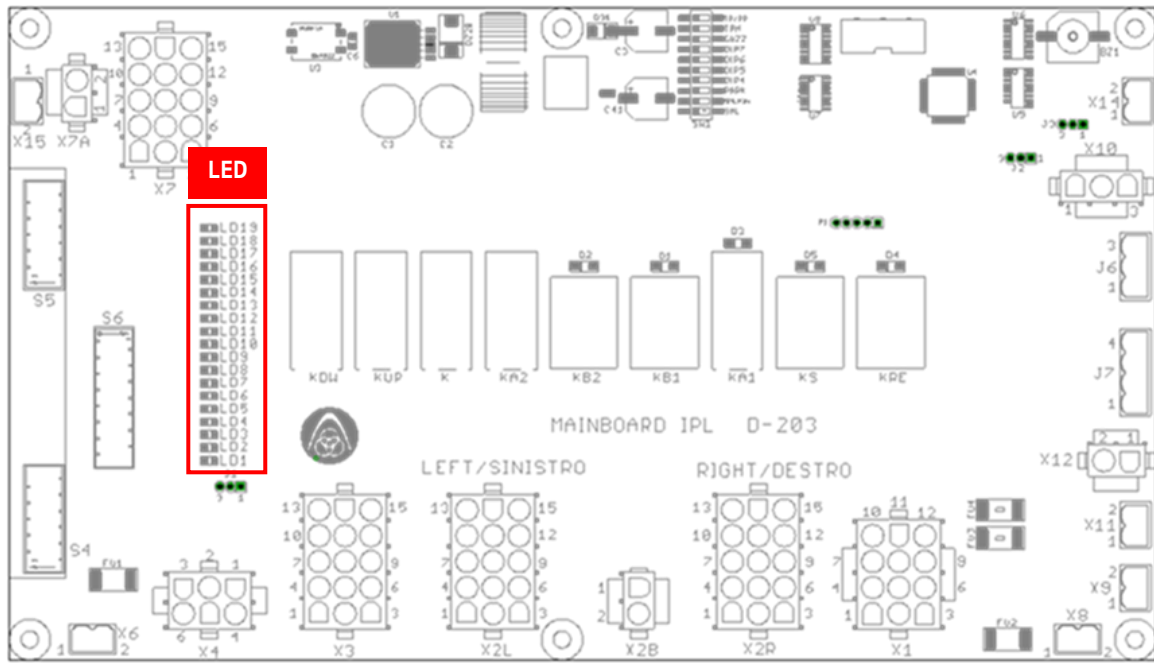

Below is the description of the Mainboard LED functions.

LED	FUNCTION
LD1	+24VDC
LD2	MOVEMENT ENABLING (K CONTACT CLOSED)
LD3	K RELAY TRIGGERED
LD4	HORIZONTAL SAFETY BARS
LD5	HORIZONTAL PLATFORM
LD6	DOWN CONTROL
LD7	UP CONTROL
LD8	DOWN MOVEMENT (DESCENT SAFETY CHAIN CHECKED)
LD9	UP MOVEMENT (ASCENT SAFETY CHAIN CHECKED)
LD10	BOTTOM STOP
LD11	TOP STOP
LD12	PLATFORM ACTUATOR ACTIVATION
LD13	SML ACTUATOR ACTIVATION
LD14	MAGNETIC SENSOR 1 (J7-2) (only for TP)

LD15	MAGNETIC SENSOR 2 (J7-4) (only for TP)
LD16	DECELERATION NEAR BENDS LIMIT SWITCH 1 (J6-2) (only for TP)
LD17	DECELERATION NEAR BENDS LIMIT SWITCH 2 (J6-3) (only for TP)
LD18	MICROPROCESSOR LIFE LED
LD19	POWER SUPPLY +5VDC

**IMPORTANT!**

LEDs 14 and 15 switch on simultaneously to indicate the intermediate stop.

**IMPORTANT!**

LEDs 10 and 11 switch on simultaneously to indicate the bottom stop with J1 between PIN 2-3.

SHEET	DESCRIPTION/OPERATION
DESC/OP E-SUP-03	RADIO RECEIVER FEATURES

OPERATORS INVOLVED	1
--------------------	---

TIME REQUIRED (minutes)	-
-------------------------	---

NECESSARY PPE				DIFFICULTY LEVEL		
						

RECOMMENDED EQUIPMENT
<ul style="list-style-type: none"> ▪ Ballpoint pen ▪ Small plastic flat-head screwdriver

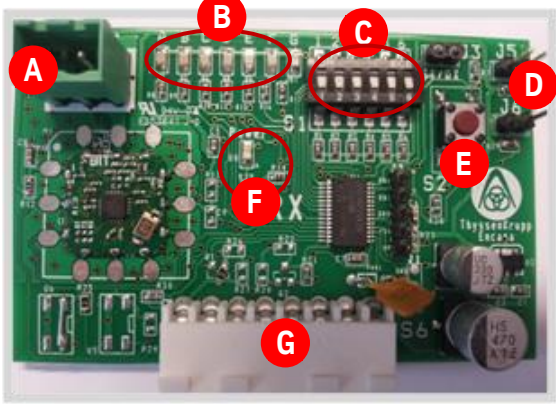
COMPONENTS	IMAGE
<p>A: Antenna B: LED C: Dip D: Jumpers E: Switch S2 F: Power G: S6</p>	

TECHNICAL FEATURES	
POWER SUPPLY	5Vdc
ABSORPTION	25-30 mA
RADIO CHANNELS	16 channels on 433 Mhz band (from 433.150 Mhz to 434.650 Mhz)
SERIAL	TTL (to communicate with the Mainboard)
INTERFACE	With Mainboard via connector S6

DIP SWITCH	
DIP 1	Frequency selection
DIP 2	Frequency selection
DIP 3	Frequency selection
DIP 4	Frequency selection
DIP 5	Not used

DIP 6	Repeater presence selection
--------------	-----------------------------

JUMPER

J3	Not used
J5	Eliminates the far/near interlock (only in the presence of RPSP straight machine)
J6	Enables the view of the second level, which must be used in the presence of the technical support service.

BUTTONS

S2	For far/near calibration
-----------	--------------------------

Below is the description of the radio LEDs:

LED	FUNCTION
POWER	Signals power supply
G	Signals: <ul style="list-style-type: none"> • serial activity (it flashes if a control is enabled or every minute) • low battery (signal provided at the end of the radio control; the LED remains on for 2-3 seconds)
F	Signals the reception of a radio signal

SHEET	DESCRIPTION/OPERATION
DESC/OP E-SUP-04	BLOCK STATUS

The system may block in the event some conditions are met.

Block conditions are clear if the system:

- is stopped at the top or bottom floor with green LED on check panel off.
- it produces a continuous sound for about 10 seconds upon every control provided
- it allows the platform to open/close only.

The machine block status can be identified by activation of the **A+B+C** LEDs on the radio receiver.

**IMPORTANT!**

Contact the technical support service if the system is blocked.

SHEET	DESCRIPTION/OPERATION
DESC/OP E-SUP-05	TOP AND BOTTOM STOP OPERATION LOGIC

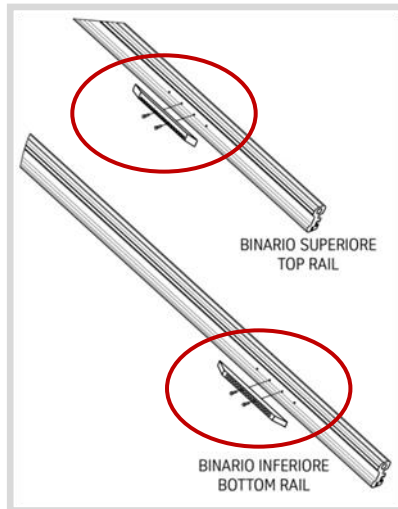



Below is the description of the top/bottom stop operation logic:

LOGIC	DESCRIPTION	IMAGE
1	The machine manages the top and bottom stop with 2 microswitches, which are placed on the lower carriage and are activated by mechanical cams.	
2	Two "NO" magnetic sensors are on the upper carriage and a plastroferrite cam is on the top rail in the presence of a fast machine. When a sensor is engaged, the machine slows down until it stops engaging the lower microswitch with the mechanical cam (see logic 1).	

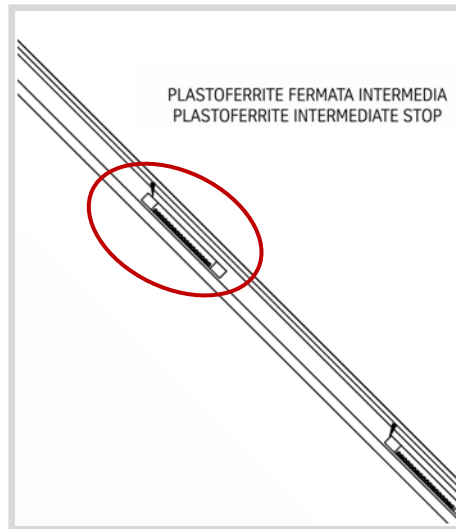
SHEET	DESCRIPTION/OPERATION
DESC/OP E-SUP-06	OPERATION LOGIC OF INTERMEDIATE STOPS AND DECELERATION NEAR BENDS



Below is the description of the operation logic of the intermediate stop and deceleration near bends:

LOGIC	DESCRIPTION	IMAGE
1	In case of intermediate stop (regardless of whether the machine is fast or slow), there are two magnetic sensors on the upper carriage and a plastoferrite cam on the top rail. The machine slows down when the first sensor is engaged. The machine stops when also the second sensor is engaged.	
2	The deceleration near bends sensors are available when the machine is in fast mode. The function is enabled by two mechanical microswitches on the upper carriage next to the magnetic sensors. The machine slows down as soon as the micro switch moves away from the guide.	

SHEET

DESCRIPTION/OPERATION

DESC/OP E-SUP-07

CHOPPER OUTPUT/INPUT CONNECTIONS

The 4-quadrant drive is configured for permanent magnet DC traction motor (powered with 24 Vdc) which allows you to vary and invert the machine translation speed.

A microprocessor, which adjusts the speed, motor current and any fault, controls the drive. A complete diagnostics highlights wiring errors in the system and allows the protection of the drive.

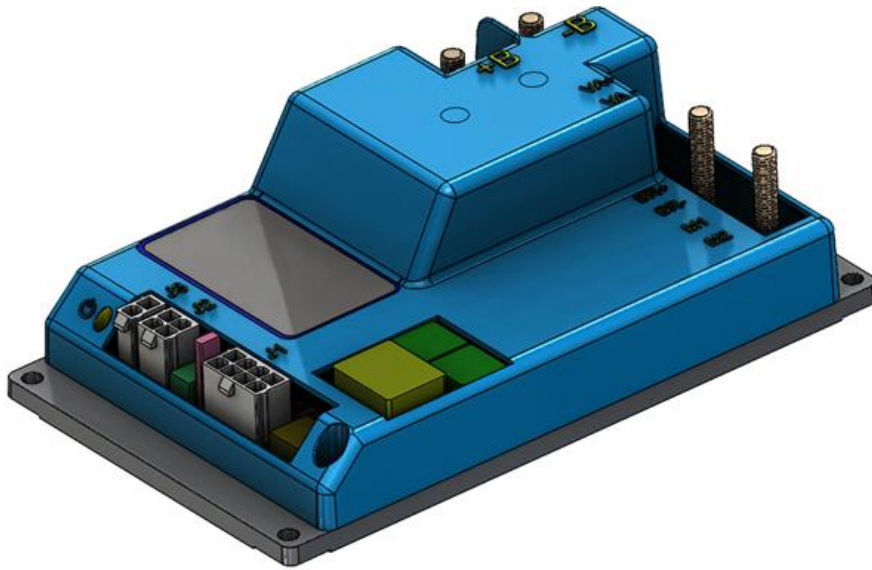

COMPONENTS

IMAGE

- A: GREEN LED (board status)
- B: Connector J3
- C: Connector J2
- D: Dip switch
- E: Connector J1
- F: RED LED (alarm)
- G: Trimmer T1
- H: Up / down buttons

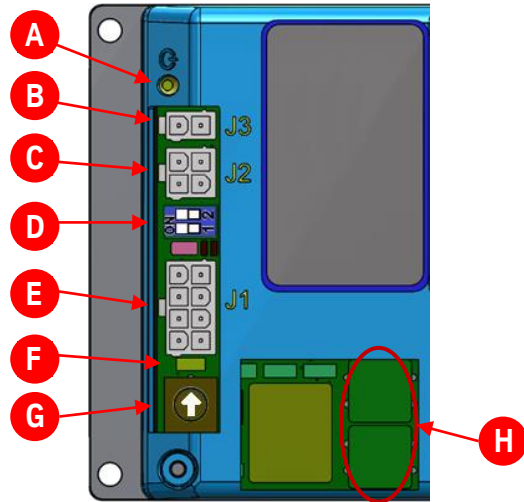

- I: Positive power supply
- J: Negative power supply
- K: Motor 1
- L: Motor 2

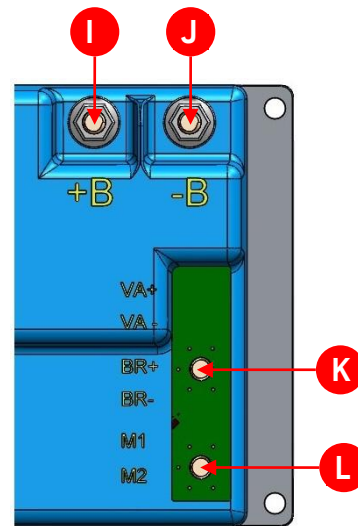

SHEET	DESCRIPTION/OPERATION
DESC/OP E-SUP-08	CHOPPER DIAGNOSTICS

The board is fitted with two LEDs. The green LED indicates the proper operation of the driver while the red LED indicates the presence of faults. Alarms may stop the machine. Below is a list of alarms related to the red error LED. The LED flashes and indicates the number of the malfunction detected.

Below is a list of possible **chopper alarms**:

ALARM	3: Electric brake failed
CAUSE	Fault in the electric brake drive.
INTERVENTION	Check the component (interrupted reel) and connections. Replace the board (possible drive MOS in short circuit) if the brake circuit is operating.

ALARM	5: Thermal protection
CAUSE	Dissipator temperature higher than 85°C
INTERVENTION	Switch the system off, wait for a few minutes and check the consumptions.

ALARM	6: Power damaged
CAUSE	Power partially damaged.
INTERVENTION	Replace the controller.

ALARM	7: Overcurrent (short-circuit)
CAUSE	
INTERVENTION	Check the motor connections and replace the controller if the alarm persists.

ALARM	8: Damaged power relay on board the machine
CAUSE	
INTERVENTION	Check the power connections and the power supply level (>17 V). If the alarm persists, even with high voltage on the bus bar (> 26 Vdc), replace the controller.

ALARM	9: Undervoltage
CAUSE	Power supply voltage lower than 17 V for more than 1 second.
INTERVENTION	Check the connections and the power supply.

ALARM	10: Overvoltage
CAUSE	Battery voltage higher than 45 V.
INTERVENTION	Check the connections and the power supply.

ALARM	11: Overload
CAUSE	
INTERVENTION	Check the operating current consumed by the motor and the "rated current" and "overload time" parameters. The "rated current" parameter varies according to the dip 1 configuration.

ALARM	12: Incorrect DRV_RUN output
CAUSE	Inconsistency on DRV_RUN output detected.
INTERVENTION	Replace the board if the alarm persists.

ALARM	13: Switch-off sequence failed
CAUSE	Drive failed to switch off.
INTERVENTION	Replace the board.
ALARM	14: Internal memory alarm
CAUSE	
INTERVENTION	Check the setting of the parameters and replace the controller if the alarm persists.
ALARM	16: Power stage alarm
CAUSE	
INTERVENTION	Replace the board if the alarm persists.

SHEET	DESCRIPTION/OPERATION
DESC/OP E-SUP-09	BRAKE BOARD

The brake board controls the movement of the parachute during machine operation. This component is contained inside the parachute and is powered every time a run control is provided. The board stops the machine if the oscillating lever fails to pass inside the U3 optical sensor within 3 seconds during the run control.

The table below provides the **functions of the LEDs and connectors:**

LABEL / LED	FUNCTION
X1	Terminal 1 (Used on right machine)
X2	Terminal 2 (Used on left machine)
LD1 (GREEN)	Power
LD2 (RED)	Flashing during CPU operation
LD3 (RED)	Status of the U3 optical sensor (Switched on in the presence of the oscillating lever)
LD4 (RED)	Board fault (If it switches off during operation)

Below is the **wiring table** for both terminal boards (X1 and X2):

SILK SCREEN PRINTING	WIRE COLOUR
+ 24V	BROWN
GNT	BLACK OR GREEN
OUT NO	GREY OR RED
OUT NC (version D-035-4)	WHITE OR BLUE

Proceed as follows to **intervene on the wired brake board:**

STAGE	DESCRIPTION	IMAGE
1	<p>Open the parachute.</p> <p>IMPORTANT! Once the parachute is open, disconnect the wire from terminal "OUT NO" to prevent the lift platform from moving.</p>	

Below is the description of the possible fault on the brake board and relative restore procedure:

DIAGNOSTICS

Parachute intervened electronically: if the machine fails to move, the KM contactor is triggered for an instant and the red LED on the casing on top of the machine flashes.

RESTORE PROCEDURE

Hold the up/down control for at least 1 minute until the red LED (on the right) on the casing on top of the machine stops flashing.

SHEET	DESCRIPTION/OPERATION
DESC/OP E-SUP-10	SUMMARY OF THE RADIO CONTROL DEVICE FUNCTIONS (TRANSMITTERS)

The table below shows the controls for the various stops of the **2-function control device**:

CONTROL	TOP FLOOR	BOTTOM FLOOR	INTERMEDIATE STOP
UP	WITH PLATFORM CLOSED	WITH PLATFORM CLOSED	WITH PLATFORM CLOSED
DOWN			
OPEN	ONLY AT TOP FLOOR	ONLY AT BOTTOM FLOOR	NEVER
CLOSE			

The table below shows the controls for the various stops of the **4-function control device**:

CONTROL	TOP FLOOR	BOTTOM FLOOR	INTERMEDIATE STOP	RADIOCONTROL
UP	WITH PLATFORM CLOSED	WITH PLATFORM CLOSED	WITH PLATFORM CLOSED	WITH PLATFORM OPEN OR CLOSED
DOWN				
OPEN	ONLY AT TOP FLOOR	ONLY AT BOTTOM FLOOR	ONLY AT INTERMEDIATE STOPS	ANY STOP
CLOSE				



Warning! A safety interlock prevents the machine from being moved with the lateral mobile slide open. On first operation the platform must be forced closed before the machine can be moved.

[PAGE INTENTIONALLY LEFT BLANK]

[PAGE INTENTIONALLY LEFT BLANK]

ThyssenKrupp Encasa



ThyssenKrupp