



Alinker R-revolution®



User manual

I. About this manual

Congratulations on your purchase of the Alinker R-volution.

This manual contains instructions for adjusting and using the Alinker. Carefully read these instructions and keep them accessible for reference. Always observe the recommendations included in these instructions.

The manual is intended for:

- people using the Alinker.
- people helping other people use the Alinker.

Explanation of the icons:



Caution: Contact your dealer or service@thelinker.com



Caution / warning



Caution: Risk of getting jammed

II. Alinker Intro & safety

Under the terms of your purchase agreement all new users are required to read the next section called “Welcome First Time Users”.

Welcome First Time Users! Please read this introductory section

Answers to other topics like transporting, assembly and maintenance in the following sections and if you do not find what you are looking for please contact us.

REGISTRATION - REQUIRED!

First, if you have not already registered online please do so now here because registrations is **required for your warranty to be in effect**.

Finally, read the first section of this manual which will familiarize you with the unique operations required to safely operate your Alinker.

Pay especial attention to any items where the caution symbol is shown here to the right:



SAFETY FIRST

PLEASE WATCH all the instruction videos which are on The Alinker Inventions YouTube Channel. The video's will address all the following issues, further to the manual.

Playlists:

- Manual
- Assembly Instructions

EVEN THOUGH AN “ALINKER” WALKING BICYCLE LOOKS LIKE A BIKE
IT IS DESIGNED DIFFERENTLY — SO EXPECT IT TO BEHAVE DIFFERENTLY TOO!

1. NO PEDALS

- You walk and stop easily using your foot, do not rely on hand-brake!
- So you **don't want to exceed speed limit 3 mph** which will make braking and stopping quickly more difficult.
- Avoid resting feet too close to front wheels.

2. UPRIGHT / STANDING POSITION

- Benefit: seeing and being seen while keeping your balance.
- Risk: upright means your center of gravity means you need to be more careful when turning and when on a tilted slope! To minimize this risk seat must not be more than 4” (10cm) above stem to reduce risk of tipping; if need seat higher order a taller Alinker.

3. Before riding, become familiar with it.

As already indicated it has no pedals and you are in a standing position which means it is unlike any other device you have used in the past. You do need to sit down while you walk. In fact you walk on wheels. Putting your weight on the saddle makes for better balance.

- Handlebars
- Seat
- Hand Break

- **how to get on and off**
- Practice on level ground **slowing down and stopping** using one or both feet since the hand brake is primarily intended to keep the bike from rolling on an incline and not for stopping the bike.
- Because of its unique design there are certain other adjustments you need to make when you go up or down hills, make turns, or ride on surfaces that are tilted
 - **on uphill grades**
 - **on downhill grades**
 - **on making turns**
 - **on canted surfaces**
- Two other unique characteristics of the bike need to be understood:
 - the front wheels are designed to quick release (“pop off” easily) for transporting and shipping; exercise care when you walk on the bike through narrow spaces near furniture, obstacles, through doors or hallways that you don’t unintentionally depress these pop off locks making it unsafe to operate.
 - also, be careful not to move your feet too close to front wheels if you rest your foot on the convenient crossbar connecting the front wheels else you might catch your shoe in the spokes injuring yourself or damaging the wheel.

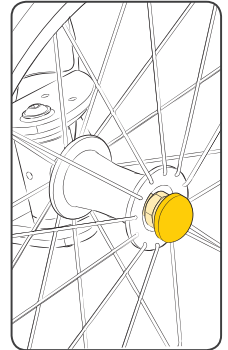

- Transporting in your car.
- Packing Instructions for common carriers such as on trains, buses, airlines,
- Product Specifications.
- Adjusting and Maintenance.
- Using compatible bicycle parts including seats, handlebars, etc.
- Assembly When your Alinker first arrives if not assembled by dealer, inspect shipping carton to make sure it hasn’t been dropped or tampered with.
- If no shipping damage apparent, open carton and verify all parts present before starting.
- If there is any apparent damage or missing parts, please contact us immediately and hold on to packing materials.
- If everything seems in order please follow these instructions to assemble. (as well as the videos which will make every step insightful.)



Table of contents

| | | |
|-----------|---|-----------|
| 1. | Safety and Operations..... | 7 |
| 1.1 | Intended use..... | 7 |
| 1.1.1 | Minimum requirements for safe use..... | 7 |
| 1.1.2 | Safety instructions..... | 7 |
| 1.2 | Misuse..... | 7 |
| 1.3 | Liability..... | 8 |
| 1.4 | Using the Alinker | 8 |
| 1.4.1 | Before first use..... | 8 |
| 1.4.2 | Get on/off..... | 9 |
| 1.4.3 | Get on..... | 9 |
| 1.4.4 | Get off..... | 10 |
| 1.5 | The Alinker stand..... | 10 |
| 1.6 | Brakes..... | 10 |
| 1.7 | Using the parking brake..... | 11 |
| 1.7.1 | Set the parking brake of the Alinker..... | 11 |
| 1.8 | Ride over a curb or up/down a slope | 12 |
| 1.8.1 | Riding over a curb..... | 12 |
| 1.8.2 | Ride up a slope..... | 12 |
| 1.8.3 | Ride down a slope..... | 12 |
| 1.9 | Ride on a canted surface (a surface slanted sideways) | 13 |
| 1.10 | Make a turn | 13 |
| 1.11 | Other cautions | 13 |
| 1.12 | Which size Alinker | 14 |
| 1.12.1 | How to measure your inseam..... | 14 |
| 2. | Description..... | 15 |
| 2.1 | Overview of the Alinker | 15 |
| 2.2 | Delivery | 15 |
| 2.3 | Options (accessories)..... | 16 |
| 3. | Adjust the Alinker | 17 |
| 3.1 | Adjust the saddle (bike seat)..... | 17 |
| 3.1.1 | Choose a saddle (bike seat)..... | 17 |
| 3.1.2 | Height and position of the saddle (bike seat)..... | 17 |
| 3.1.3 | Adjust the saddle (bike seat) to the correct height..... | 18 |
| 3.2 | Adjust or change out the handlebar if needed..... | 18 |
| 3.2.1 | Select handlebar and a handlebar stem riser for your comfort and need | 18 |
| 3.2.2 | Position of the handlebars..... | 18 |



Table of contents

| | | |
|-------|--|-----------|
| 3.2.3 | <i>Adjust the handlebar to the correct position.....</i> | <i>18</i> |
| 3.3 | Adjust the brake if needed..... | 19 |
| 4. | Transport the Alinker | 20 |
| 4.1 | The front wheels..... | 20 |
| 4.1.1 | <i>Put the front wheels on.....</i> | <i>20</i> |
| 4.1.2 | <i>Remove the front wheels.....</i> | <i>21</i> |
| 4.2 | Fold the Alinker | 22 |
| 4.2.1 | <i>Fold the Alinker.....</i> | <i>22</i> |
| 4.2.2 | <i>Un-folding the Alinker.....</i> | <i>22</i> |
| 4.3 | The saddle (bike seat)..... | 23 |
| 4.3.1 | <i>Putting the saddle (bike seat) on.....</i> | <i>23</i> |
| 4.3.2 | <i>Remove the saddle (bike seat).....</i> | <i>23</i> |
| 4.4 | Place the Alinker into the car | 23 |
| 5. | Maintenance | 24 |
| 5.1 | Check tire pressure..... | 24 |
| 5.2 | Clean and lubricate | 24 |
| 6. | Product specifications | 25 |
| | Appendix A: Assembly instructions,first use guidelines and suggestions..... | 26 |

1. Safety and Operations

1.1 Intended use

The Alinker R-evolution is a walk assist for peverybody who wants to stay active.

1.1.1 Minimum requirements for safe use

- Be able to walk to some degree. You must be able to flex and extend your legs.
- Be able to bear weight on one leg briefly while getting on and off the Alinker.
- Be consciously aware of your surroundings.
- Be aware of your ability and limitations.

1.1.2 Safety instructions

For safe use of the Alinker:

- Properly adjust the saddle and the handlebar of the Alinker. *See 5. Adjust the Alinker.*
- Observe the traffic rules.
- Stay on the sidewalk or designated walking path when possible.
- Always be considerate of the other people as they cannot always hear or see you. You may move faster on the Alinker than other people in your surroundings.
- Do not go faster than 5 km/hour (3 miles/hr).
- Before using the Alinker near other pedestrians and moving vehicles you must minimally have these skills:
 - Use the Alinker while being aware of your surroundings.
 - Make turns easily and smoothly.
 - Navigate curbs and slopes in a controlled way.
 - Use the handbrake and your feet to slow down when necessary.
 - Know your limitations, keep the Alinker at a speed which you can safely navigate obstacles.
- Be aware that when you put a foot on the fork, there is a risk that this foot can slide between the spokes. If needed, contact your dealer or service@thealinker.com to find out how to have modifications made for your Alinker, such as special footrests.

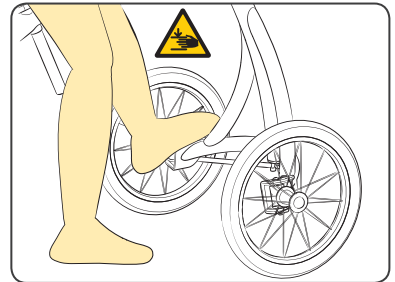

Contact your dealer or service@theAlinker.com

- In case of defects or for service, make an appointment with the dealer or service@thealinker.com.

1.2 Misuse

The Alinker is not intended to use on stairs, uneven terrain and slopes steeper than 5 degree or go faster than 5km/hr (3 miles/hr)

1.3 Liability

The Alinker Inventions Ltd and Alinker Europe bv does not accept any liability for improper use, which is any use other than indicated in the manual or in line with the instructions of the premium dealers.

- Only use the Alinker when you have sufficient skills. The most important of these are given below:
 - Use the Alinker while being aware of your surroundings.
 - Make turns easily and smoothly.
 - Navigate curbs and slopes in a controlled way.
 - Use the handbrake and your feet to slow down when necessary.
 - Know your limitation, keep the Alinker at a speed at which you can safely navigate obstacles.
- Regularly check the Alinker for correct operation of parts and do not use the Alinker when you know that any part is defective. Have the part repaired before using.
- Observe the traffic rules.
- As a pedestrian you must not go faster than 5 km/hour (3.1mph) and after sunset you must have lighting with reflectors.

1.4 Using the Alinker

When you move 5 km/hour (3 miles/hr) or slower on the Alinker, you are regarded as a pedestrian in traffic. You may then use the Alinker on footpaths, sidewalks and in public areas.

When you go faster than 5 km/hour (3 miles/hr), you are regarded as a cyclist in traffic and it's more appropriate to ride on a designated bike path. Be aware of your speed relative to others. Your Alinker must have lighting and reflectors after dark.

1.4.1 Before first use

- Properly adjust the saddle and the handlebar of the Alinker. *See 3. Adjust the Alinker.*
- Practice with the Alinker in a quiet area without traffic. Make sure that you are not alone when you try the Alinker for the first time.
- Practice getting off and on safely. Lock the handbrake while practicing. *See 1.4.2 Get on/off.*
- Practice making turns to the left and to the right. *See 1.10 Make a turn.*
- Carefully practice on slightly sloping roads and curbs. *See 1.8. Ride over a curb or up/down a slope*
- Practice using the handbrake and your feet to slow down. *See 1.6. Brakes*
- Practice accelerating and decelerating

1.4.2 Get on/off

1. Get on and off from the rear of the Alinker.
2. Set the parking brake of the Alinker when getting on and off.

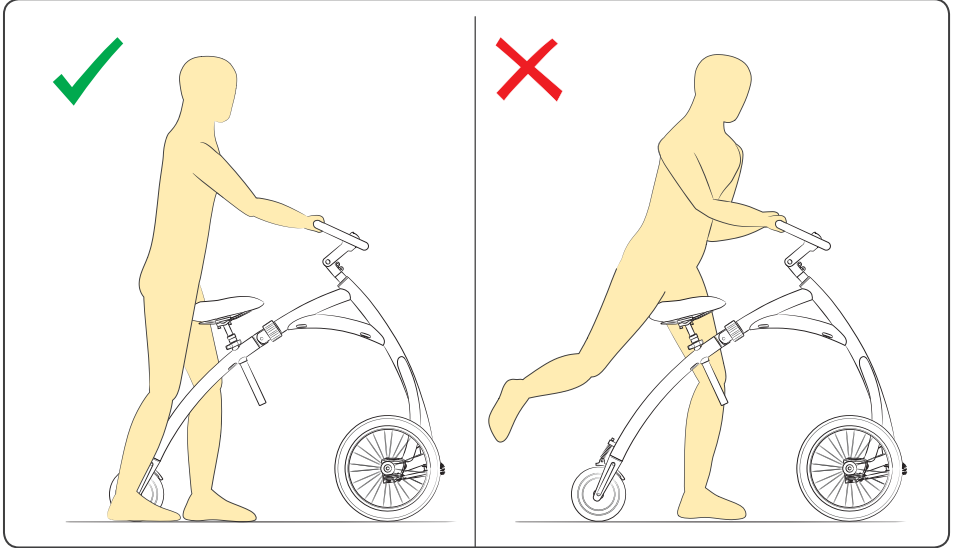

Caution: If you stand alongside the Alinker and swing your leg over the frame like you might with a bike, you may lose your balance.

1.4.3 Get on

1. Set the Alinker parking brake.
See 1.7.1. Set the parking brake of the Alinker.
2. Stand behind the Alinker and hold the handlebars.
3. Slightly lift your leg and step over the saddle.
4. Put your full weight on the saddle. Weight on the saddle gives stability when walking with the Alinker.
5. When you are seated and feel stable, squeeze the handbrake.
This unlocks the parking brake..

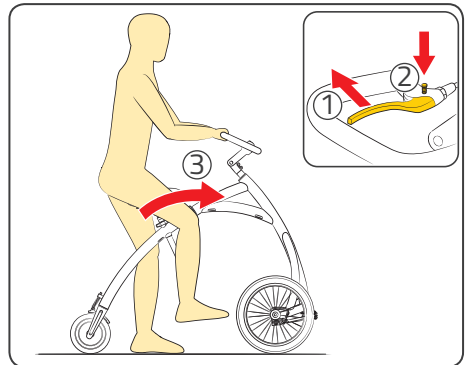

1.4.4 Get off

1. Set the parking brake of the Alinker.
See 1.7.1. Set the parking brake of the Alinker.
2. Hold the handlebar and stand up.
3. Slightly lift your leg and step backward over the saddle.

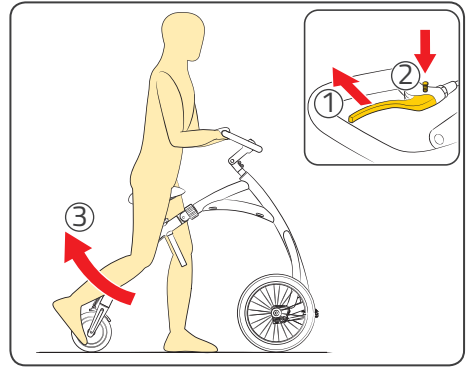

1.5 The Alinker stand

1. Fold the Alinker.
2. The Alinker will be freely standing as the stand (A) will be in contact with the floor.



See 4.2.1 Fold the Alinker instructions for folding and unfolding safely.

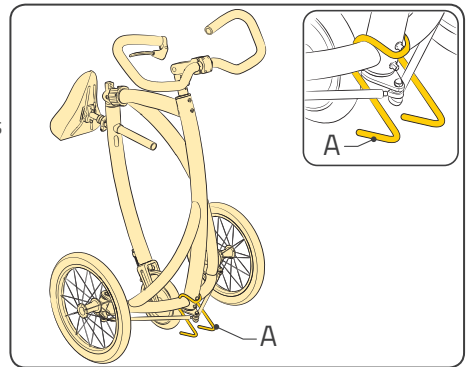

1.6 Brakes

Apply the following two methods for braking:

1. **The primary brake on the Alinker is your own feet and legs.**
2. While the saddle (bike seat) supports your weight, add resistance while descending a slope by engaging your feet and legs. Slow down using your heels.
3. Squeeze the handbrake (A) for extra brake support.



Caution: When you go faster than 5 km/hour (3 miles/hr) the functioning of the handbrake is limited. Combine the handbrake with using your feet.

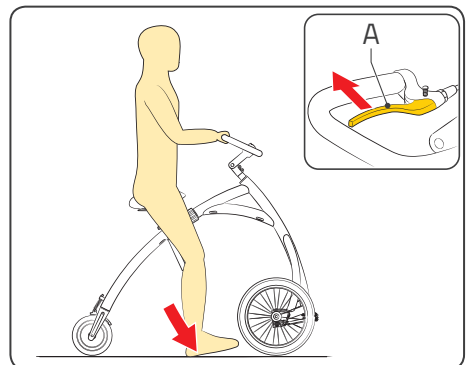

1.7 Using the parking brake

The parking brake can be used to prevent the Alinker from rolling away from you. Use the parking brake when getting on and off or when it is unattended.

1.7.1 Set the parking brake of the Alinker

1. Squeeze the handbrake (A) all the way.
2. Press the catch (B) on the brake down and let go of the handbrake (A).

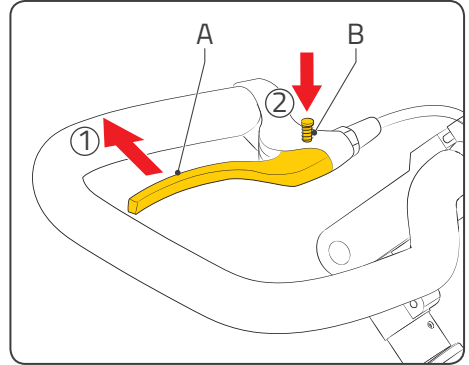

Take the parking brake off the Alinker

1. Squeeze the handbrake (A). The catch will automatically move up and the Alinker parking brake will be unlocked.

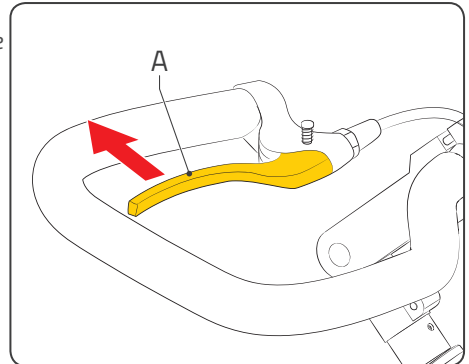

1.8 Ride over a curb or up/down a slope

1.8.1 Riding over a curb

Carry out the following instructions simultaneously:

- Approach the curb squarely with the front wheels at 90 degrees to the curb. Make sure that both wheels go off the curb at the same time in a slow and controlled manner.
- Keep your weight on the saddle (bike-seat). This increases the stability.
- Take small steps forward, then lift your weight off the saddle so the rear wheel can roll off the curb behind you.

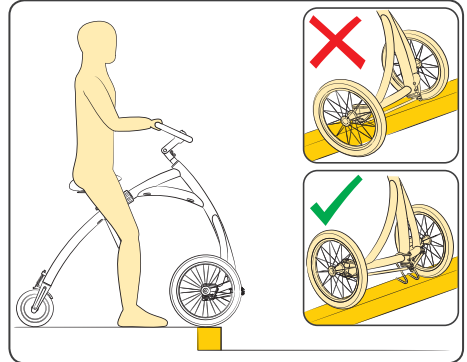

1.8.2 Ride up a slope

Carry out the following instructions simultaneously:

- Approach the slope squarely with the front wheels at 90 degrees to the slope.
- Lean your body forward in order to be able to apply sufficient power with your legs.
- Keep your weight on the saddle (bike-seat). This increases the stability.
- For comfort you may want to lower the saddle to ascend a long slope.

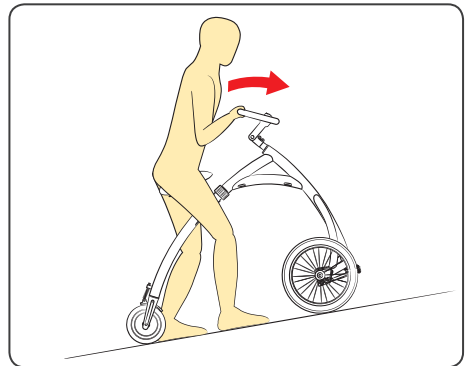

1.8.3 Ride down a slope

Carry out the following instructions simultaneously:

- Approach the slope squarely with the front wheels at 90 degrees to the slope. Use your feet and the handbrake (A) to slow down.
- Use your body as a counterweight. Lean your body backward and use your legs to control the speed when going down.
- Keep your weight on the saddle (bike seat). This increases stability.

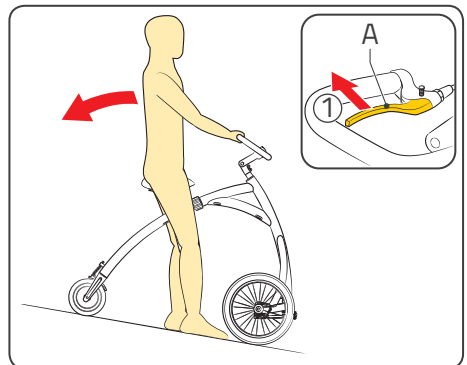

1.9 Ride on a canted surface (a surface slanted sideways)

Simultaneously carry out the following instructions when making a turn:

- Use your body as a counterweight. Lean your body towards the slope.
- Keep your weight on the saddle (bike seat). This increases the stability.



Caution: Do not ride on canted surfaces that are steeper than 5 degrees.

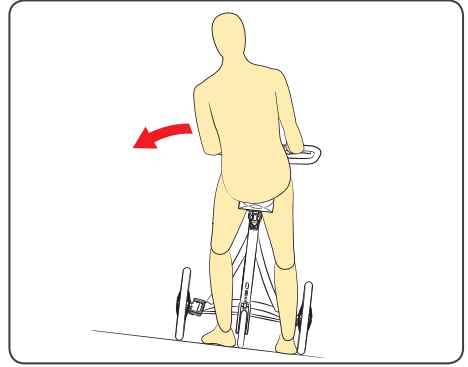

1.10 Make a turn

Simultaneously carry out the following instructions when making a turn:

- Slow down and take smaller steps.
- Always keep four or five points of contact on the ground while riding.
- Use your body as a counterbalance, just like when biking. Make sure that the center of gravity (A) of your body remains within the triangle.



Caution: Be aware there is a tipping point where the Alinker will come up on 2 wheels if turns are taken too fast. Slow down, take small steps when turning.

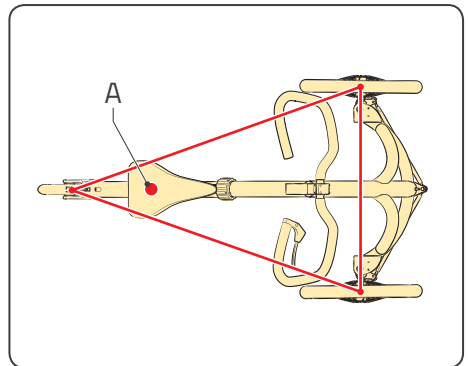

1.11 Other cautions

Avoid bumping into furniture or obstacles. If the Alinker wheel comes into contact with an object, and the black center button is depressed, the front wheel can unlock and come loose. Check the black button on the front wheel to be sure it is not sticking out while riding.



Caution: Stop immediately when you see the black button stick out and re-fasten the wheel.

See 4.1.1. Put the front wheels on

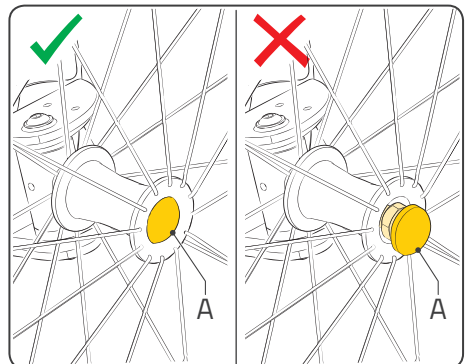

1.12 Which size Alinker

The Alinker must be sized by your inseam measurement.



Measure your inseam yourself or with help from your dealer

- Have a dealer take your measurements personally for a Alinker. Table 1 gives an indication for the suitable model for a certain physical height.

| Inseam | Model |
|------------------------------|--------|
| 68 - 77.5 cm (27" – 30.5") | Small |
| 77.5 - 87 cm (30.5" – 34.5") | Medium |
| 87 - 99 cm (34.5" – 39") | Large |

Table 1 physical height and model

1.12.1 How to measure your inseam

3. Stand against the wall and take a hard cover book, put it between your legs against the wall. You want it to be level and square.
4. Have someone take the measurement between the floor and the top of the book.

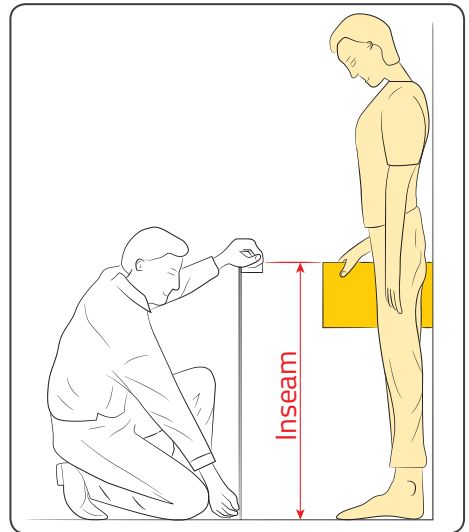

2. Description

2.1 Overview of the Alinker

The Alinker consists of:

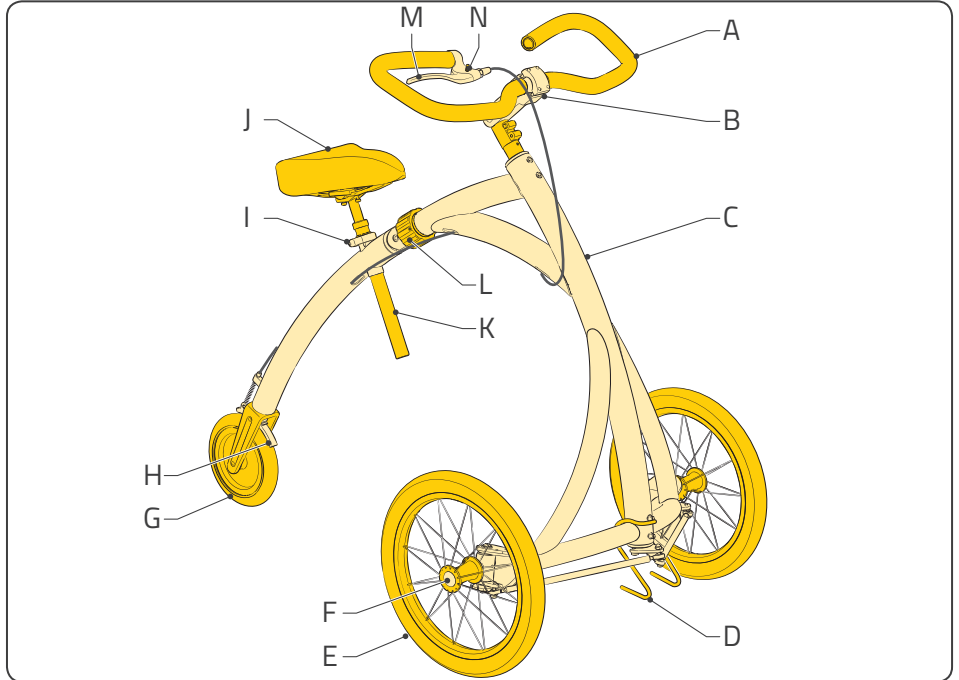

- | | |
|---------------------------|-----------------------------|
| A. Handlebar | H. Rear brake |
| B. Handlebar riser | I. Quick release for saddle |
| C. Folding frame | J. Saddle |
| D. Stand | K. Saddle pin |
| E. Two large front wheels | L. Hinge |
| F. Quick release hub | M. Handbrake |
| G. Small rear wheel | N. Parking brake catch |

2.2 Delivery

The Alinker is delivered nearly completely assembled. Only wheels, saddle and steering needs to be put in place. (Follow the assembly instructions).

2.3 Options (accessories)

There are no accessories for the Alinker yet available through the Alinker Inventions. Bicycle accessories (e.g. a saddle, saddle pin, handlebar, handlebar riser, basket, lighting, etc.) can be mounted unto the Alinker. Specific accessories for the Alinker will be developed.



Baskets mounted the steering are highly advised against as the weight of the basket (and contents) might compromise the steering mechanism. Using a basket on the steering will void the warranty. A basket should be braced around the frame tubes. Drilling in the front tube might compromise the steering mechanism and should be avoided. Drilling in the front tube will void the warranty.

Check the website www.theAlinker.com for updates and announcements.

3. Adjust the Alinker

Please follow the descriptions given below to adjust the Alinker for maximum comfort:

- Adjust the saddle (bike seat).
- Adjust the handlebar.
- Adjust the brake.

3.1 Adjust the saddle (bike seat)

3.1.1 Choose a saddle (bike seat)

The default saddle (bike seat) on the Alinker is a narrow gel saddle with a spring in the saddle pin.



Contact your dealer or local bike shop for saddle (bike seat) options

- Any type of saddle (bike seat) can be installed on the Alinker.
- Choose the saddle (bike seat) most comfortable for you. Fit is very personal!

3.1.2 Height and position of the saddle (bike seat)

The saddle (bike seat) is at the correct height if your knees are slightly bent when you have your feet flat on the ground. You must have a feeling that you are sitting just a bit too low (compared to a bike).

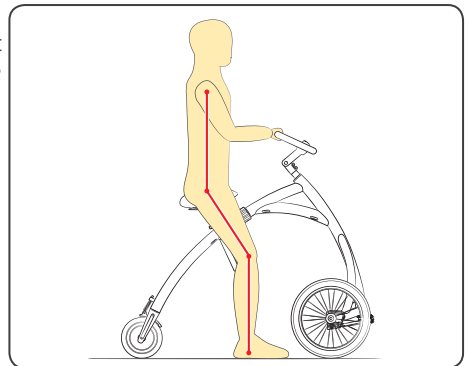

When you make a large step your feet must still easily touch the ground. The saddle (bike seat) must be horizontal.



Caution! When you go faster with the Alinker, your steps tend to be bigger and the saddle (bike seat) must be set a bit lower.

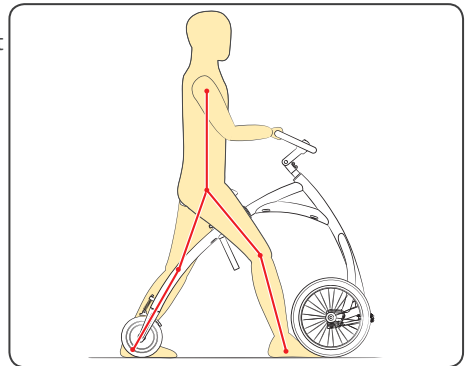

3.1.3 Adjust the saddle (bike seat) to the correct height.

1. Pull the quick release (A) outward.
2. Raise or lower the saddle (bike seat) (B) to the required height.



Caution! The saddle (bike seat) can be raised a maximum of 12 cm or 4.75" (X) from the lowest position. The higher the saddle, the higher your center of gravity and the less stable you are on the Alinker. For stability it is better to use a lower saddle on a larger frame than a higher saddle on a smaller frame.

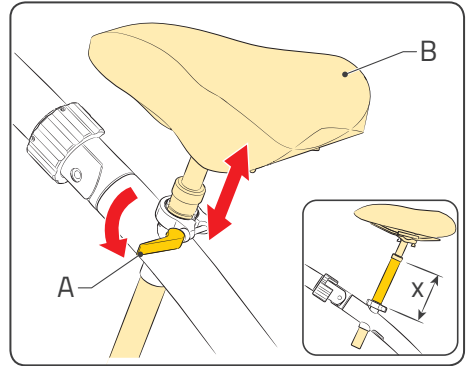

3. Fold the quick release (A) inward to lock the saddle (bike seat) in place.

3.2 Adjust or change out the handlebar if needed

3.2.1 Select handlebar and a handlebar stem riser for your comfort and need

The default handlebar for the Alinker is the butterfly handlebar.



Contact your dealer or local bike shop if you want a different handlebar configuration.

- Virtually every type of handlebar is suitable for the Alinker.
- Choose the handlebar most comfortable for you.

Choose the correct handlebar stem riser for the handlebar. Most handlebar stem risers can be removed for stowage or travel.

3.2.2 Position of the handlebars

The handlebars are in the correct position when:

- Your arms are slightly bent when you are sitting up straight,
- Your hands can easily reach the handbrake,
- When walking, using the handbrake and steering feels easy.



Contact your dealer or local bike shop

The correct adjustment of the handlebar may vary depending on the surrounding area and your speed. Your dealer or service@thealinker.com can offer advice. The dealer can make modifications to help you experience what happens when you lower the saddle and/or tilt the handlebar.

3.2.3 Adjust the handlebar to the correct position

The handlebar can be adjusted at two places:

1. The handlebars themselves can be raised or lowered using a 4mm allen key.
2. The handlebar stem riser can be raised or lowered using a 5mm allen key.

Adjust the handlebar

1. Loosen the 4 bolts (A) with a 4mm allen key.
2. Adjust the handlebar (B) to the correct position.
3. Tighten the 4 bolts (A) with a 4mm allen key.

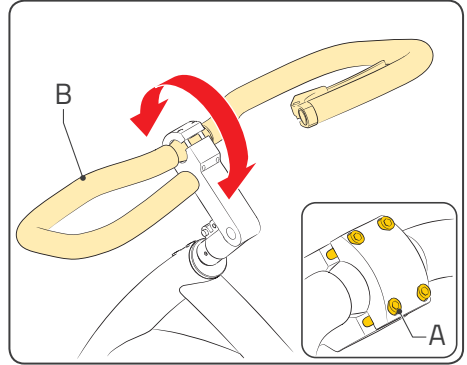

Adjust the handlebar stem riser

1. Loosen the bolt (A) with a 5mm allen key.
2. Adjust the handlebar (B) to the correct position.
3. Tighten the bolt (A) with a 5mm allen key.

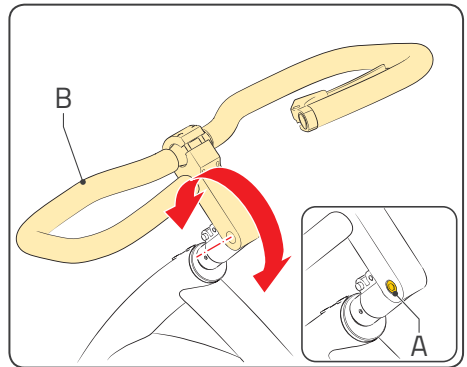

3.3 Adjust the brake if needed

Tighten the brake

1. Loosen the ring (A).
2. Unscrew the catch (B).
3. Tighten the ring (A) again.

Make the brake less tight

1. Loosen the ring (A).
2. Screw in the catch (B).
3. Tighten the ring (A) again.

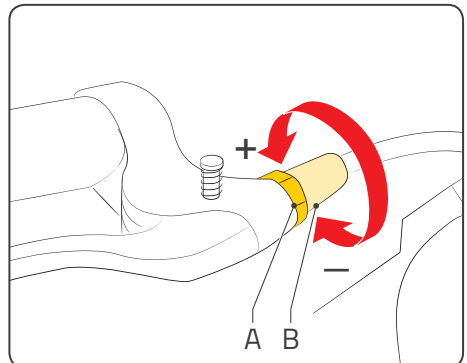

4. Transport the Alinker

The Alinker is foldable. The wheels can be clicked off the Alinker and the saddle (bike seat) can be removed. This makes the Alinker easy to transport.

4.1 The front wheels

4.1.1 Put the front wheels on

1. Hold the wheel (A) with one hand at the hub.
2. Place your fingers around the spokes. Press and hold the black button (B) with your thumb.
3. Slide the wheel onto the frame (C).
4. Release the black button (B).
5. Pull the wheel outward to be sure it has "clicked" in. It should feel secure.

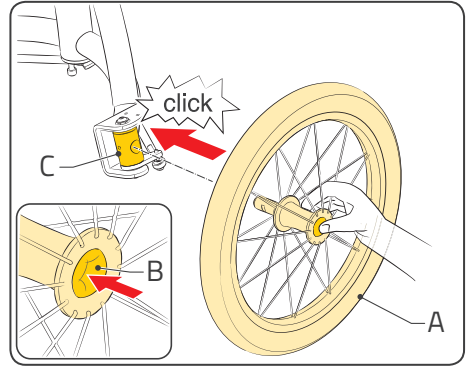

6. Double check to see if the wheel is securely fastened.



When the ball (D) is visible and the black button (B) does not stick out, the wheel is correctly fastened.

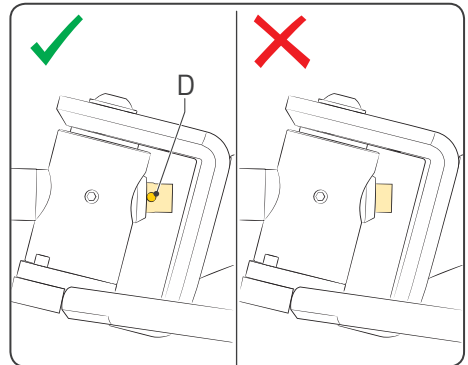

Contact your dealer or service@thelinker.com

- If you cannot properly fasten the wheel, the dealer can adjust the mechanism.

4.1.2 Remove the front wheels

1. Hold the wheel (A) with one hand at the hub.
2. Press and hold the black button (B) in with your thumb and place your fingers around the spokes.
3. Remove the wheel (A).

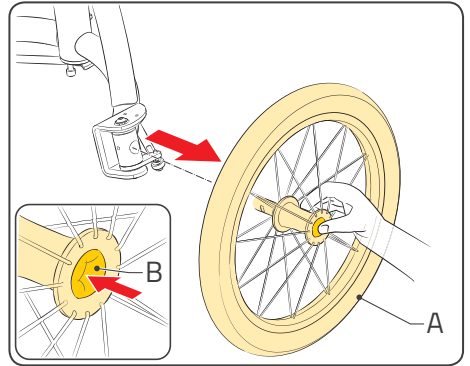

4.2 Fold the Alinker

4.2.1 Fold the Alinker

1. Turn the black ring (A) on the frame until the opening of the ring is facing upward. When the ring opening is exactly facing upward, the hinge can be opened.
2. Place one hand on the saddle and the other hand on the handlebar.
3. Lift the rear wheel up slightly off the ground.
4. Fold the Alinker by pressing down on the saddle (bike seat). The rear of the Alinker will fold toward the front.



Caution: Do not hold the frame by the hinge. Avoid pinching fingers.

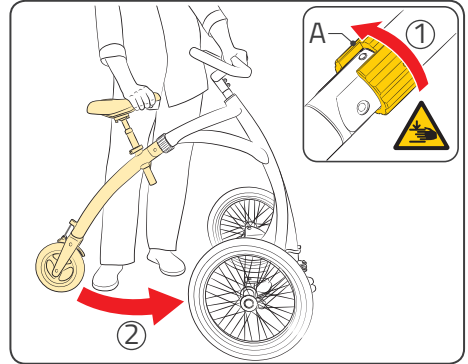

4.2.2 Un-folding the Alinker

1. Hold the saddle (bike seat) with one hand and the handlebar with the other.
2. Put one foot behind the wheel so it will not roll as you unfold the Alinker.



Caution: Do not hold the frame by the hinge. Avoid pinching fingers.

3. Pull the saddle backward to unfold the frame.
4. When the frame is fully unfolded, turn the black ring (A) downward so the opening faces the ground. The ring makes a clicking sound when it is closed and locked. The Alinker can only be used when the ring is closed.



Caution: Do not get on when the hinge has not been locked.

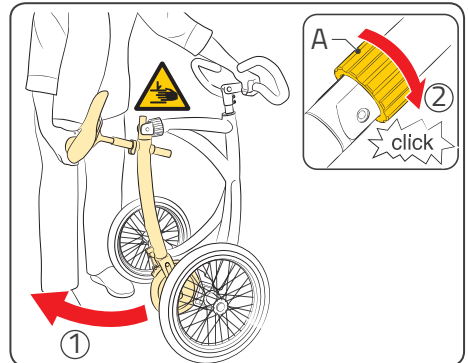

4.3 The saddle (bike seat)

4.3.1 Putting the saddle (bike seat) on

1. Fold the quick release (A) outward.
2. Place the saddle (bike seat) with the saddle pin (B) in the frame (C).
3. Slide the saddle (B) to the correct height.
See 5.1.2. Height and position of the saddle (bike seat).
4. Fold the quick release (A) inward.

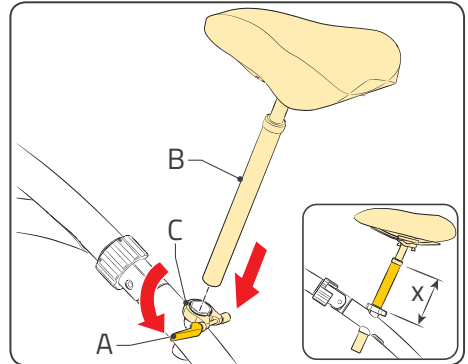

4.3.2 Remove the saddle (bike seat)

1. Pull the quick release (A) outward.
2. Remove the saddle and the saddle pin (B) from the frame (C).
3. Fold the quick release (A) inward.

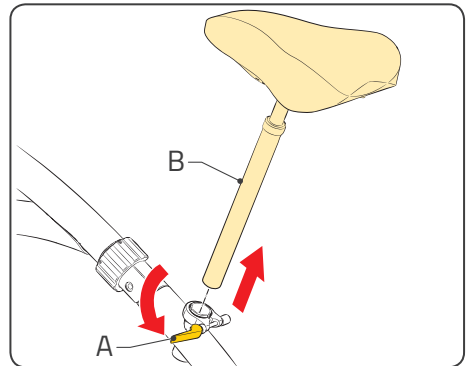

4.4 Place the Alinker into the car

1. Fold the Alinker.
2. Remove the wheels.
3. Remove the saddle (bike seat), if necessary.
4. Place the frame, wheels and saddle (bike seat) in the car.

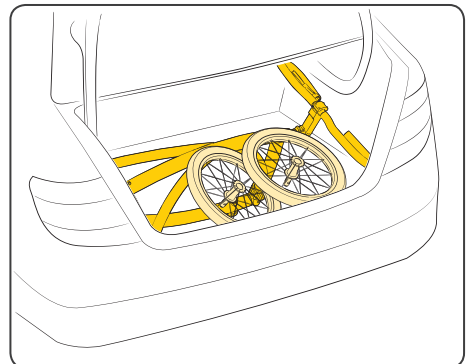

5. Maintenance

The following maintenance activities you can carry out yourself:

- Check tire pressure
- Clean and lubricate



Contact your dealer, your local bike shop or service@thealinker.com

- For other maintenance and repair.
- Order or replace parts.

5.1 Check tire pressure

The tires of the Alinker will loose pressure over time with use. Check them every week and keep them topped up to ensure your ride is smooth and efficient.

| Tire | Maximum tire pressure (bar) |
|------------|-----------------------------|
| Front tire | 2.5 |
| Rear tire | 2 |

Table 2 Tire pressure

5.2 Clean and lubricate

- Only use hot water with a mild liquid soap and a cotton cloth for large surfaces
- Grease aluminum, chrome and steel parts with acid-free Vaseline to avoid oxidation. Grease the axles of the front wheels when they appear dry.
- Do not use:
 - Strong chemicals, such as bleach, ammonia or soda.
 - Garden hose or high-pressure spraying pistol to avoid damaging the pivoting points running in bearings. They are water-repellent but not watertight.

6. Product specifications

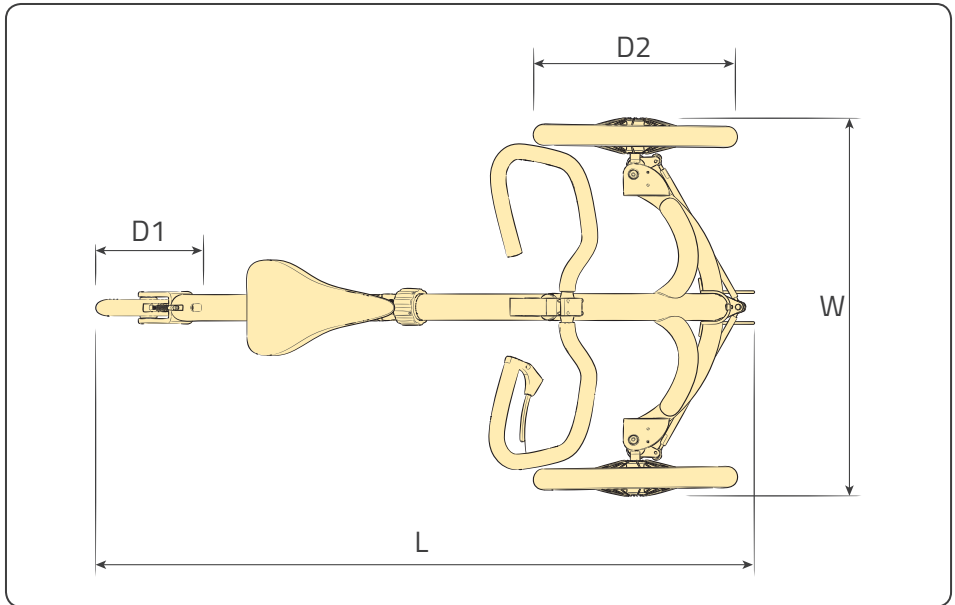

| | Small | Medium | Large |
|----------------------------|---|---------------|---------------|
| Length (L) | 1150 mm / 45" | 1240 mm / 49" | 1350 mm / 53" |
| Width (W) | 720 mm / 30" | 720 mm / 30" | 720 mm / 30" |
| Rear wheel diameter (D1) | 8" aluminum wheel with black, air-filled profiled tire | | |
| Front wheel diameter (D2) | 16" aluminum rim, stainless steel spokes, black air-filled profiled tire, quick release mechanism on the axles for quick (dis)mounting of the wheels. | | |
| Turning radius | less than 3 meters (9'84") | | |
| Frame (folding) | aluminum 6061 | | |
| Rear brake / parking brake | Handbrake (on rear wheel), cable runs through the frame Release mechanism on the axles for quick (dis)mounting of the wheels. | | |
| Weight | 12 kg (26 lb) | | |

Table 3 Specifications



Appendix A: Assembly instructions, first use guidelines and suggestions

1. Assembly and safety check: READ CAREFULLY

Assembly: When your Alinker first arrives (if not assembled by dealer), inspect shipping carton to make sure it hasn't been dropped or tampered with.

If no shipping damage apparent, open carton and verify all parts present before starting. If there is any apparent damage or missing parts, please contact us immediately and hold on to packing materials.

Open the box: Cut the tie-wraps and undo the Alinker from the wrapping material.

WARNING: Do not cut the tie-wrap on the front tube, that ties up the brake cable.

NOTE: The steering bar is connected to the frame with the brake cable, careful!

You should find:

1. Two front wheels, 2. The Alinker itself, 3. The steering bar (connected with brake cable to the frame (handle with care), 4. The saddle on the saddle pen, 5. A little package with an Allen key and the official manual.

Once you have removed all the wrapping materials:

1. Keep the frame folded up.
2. Hang the steering bar on the frame temporarily.
3. Take the front wheels. There is a left and right wheel. The arrows in the tire profile must point forward.
4. Stand the frame upright on rear wheel and front stand, balance it.
5. Tilt the frame slightly forward so you have space to insert the front wheels.
6. Push the black quick release button in the wheel hub in, so it can be inserted in the cylinder at the rotating front brackets.
7. Insert completely and release the black button so the axle is now fixed.
8. Insert the second wheel. The Alinker now stands independently on stand.
9. Take the saddle on saddle pen.
10. Open the quick release lever on the frame. Do not rotate it, just lever it open.
11. Insert the saddle pen completely and close the lever. (saddle height is later).
12. Make sure the black ring at the hinge is rotated with opening to top.
13. Hold the back of the saddle and put your other hand on the top of frame.
14. **WARNING:** Keep hands/fingers away from the hinge.
15. Pull the saddle up and backward, unfolding the frame. Landing the Alinker on 3 wheels.
16. Rotate the black hinge ring 180 degrees to close it, you feel a 'click'.
17. **NOTE:** Always close the hinge ring before using the Alinker.
18. Take the steering bar and fit it on the top of the steering mechanism.
19. Make sure the brake cable is looped behind and over the steering head, so it is free and not overstretched.
20. Take the Allen key 4mm, provided with the manual.
21. Stand in front of the Alinker with your feet on the insides of the wheels.
22. Keep them aligned forward. Align the steering bar with the wheels.
23. Tighten the 2 Allen screws on the front of the steering head.
24. Your Alinker is now ready to be adjusted to your requirements.

Check the tire inflation on all three tires, check function of the handbrake.



2. Adjusting the saddle:

While sitting on the Alinker notice what needs to be adjusted for proper use and comfort. The saddle should be lower than you might think, it is not a bicycle.

WARNING: Do not put the saddle higher than 4" (10cm) higher than the lowest position. Make sure there is always minimum 2" (5cm saddle pen below the frame.

Adjusting the saddle: When the saddle is the correct height, your feet should be flat on the floor with your knees slightly bent. You should be able to make a good step and still have your feet on the ground. When you sit too high, you cannot get sufficient traction and you strain yourself too much.

IMPORTANT: Sit with your sitbones on the back edge of the saddle. Your pelvis tips backward a bit, which releases your lower back and is more comfortable on the saddle.

The saddle should be adjusted level, so it tips a bit up. That is personal, but experiment a bit with the level of the saddle to find your comfort. If a height adjustment is necessary, get off the Alinker and make the adjustment by loosening the quick release lever on the saddle pin, raising or lowering the saddle, then locking the quick release lever. Do not turn the quickrelease, just lever open and close. If a level adjustment is necessary, use an Allen wrench to adjust the screws under the saddle to tilt it back or forward slightly.

NOTE: it takes some time to get used to the saddle, but that is temporary as you will break it in. For longer distances you might consider using padded cycle pants. In principle every bike saddle can be fitted to the Alinker. Note that a wider saddle makes strides and full use of your hip joints harder and not preferred.

3. Two methods of getting on and off the Alinker

A. Unlock the parking brake

Getting on the Alinker: Stand behind the Alinker saddle facing forward. Lean forward and put your hands on the handle bars. Pull the Alinker toward you while slightly lifting one leg until the Alinker saddle is beneath you. Sit on the saddle with your full weight.

To get off the Alinker, reverse this process. With both feet on the ground, stand up so you are completely off the saddle, slightly lift one leg and push the Alinker away from you.

B. Alternately the parking brake can be left on while getting on the Alinker. Stand behind the Alinker, lean forward to put your hands n the handle bars. Walk around the saddle while using the support of the stabilized Alinker.

To get off the Alinker, reverse the process.

4. Adjusting the handle bar:

When you sit up straight and your arms are bent slightly, your hands should be near the handbrake. Using the brake while turning the handle bars to the left or right should be done without effort.

5. Before using the Alinker:

Practice getting on and off the Alinker.

Be sure the seat and handle bars are adjusted properly.



Appendix A: Assembly instructions

Become comfortable using the handbrake and parking brake.

Find the balance point of the Alinker by sitting with your full weight on the saddle and leaning to the right to see where it feels like it might start to tip.

Try leaning to the left until it feels like it might want to tip. For your safety when using the Alinker you will want to sit upright, staying in between these two extremes.

6. Using the Alinker-beginner

For initial use of the Alinker have someone with you as a spotter.

Select a level location with few obstructions and other traffic, preferably indoors.

Pick your route, a clear straight away in which you can walk in a straight line.

The Alinker is a walking bike; 3mph is the average walking speed. Be aware that increasing speed also increases the risk of tipping, falling or other accident.

Begin walking slowly. Have your full weight on the saddle, using your feet and legs to create forward momentum.

Keep your walking stride within the frame of the device (between the two wheels).

Try using short and long strides to see how they feel different and accomplish different things.

Keep your hands on the handle-bars at all times. Be ready to use the hand brake if necessary.

Lean to the right and to the left carefully, but without tipping, to explore the stability of the device.

Once you are comfortable walking in a straight line forward, try taking a few steps backward using small steps.

Turning the device in a circle slowly, taking smaller steps. See how tight the turning radius is. When you get off, engage the parking brake.

7. Check in and see how you feel!

What muscles did you use? Do you feel like you've exercised? Are you sore anywhere?

If you experience any pain or discomfort during or after a walk on the Alinker, contact your physician, physiotherapist or occupational therapist. They can give you advice on using the Alinker in a pain free, healthy way.

When you start walking with the Alinker, you might discover that you use muscles you haven't used for a while. This can cause muscle pain. Also, saddle sore may occur in the beginning. Like the muscle pain, it is inconvenient, but harmless.

8. Using the Alinker-advanced, going outside:

Stay in control when using the Alinker. Use caution always, especially when you get tired: 3 mph is a sensible speed limit. Slow down when you make a turn, going down a slope or when you are navigating obstacles.

Preferably, stay on the sidewalk when using the Alinker as you are considered a pedestrian.

Consider other pedestrians and cyclists. People cannot hear you approaching on the Alinker. It is easy to bump into pedestrians because you may be moving more quickly than they are.

Before taking the Alinker into busy areas in mixed traffic, master these skills:



Walking and looking around you at the same time. When you use the Alinker, look ahead, be aware of who is left and right of you (don't look at your feet / handlebar).

Making turns without having the feeling that you could fall over.

Using the handbrakes when necessary. Always have your hands on the handlebar, close to the handbrake.

Going downhill safely. Be sure you know how to use the brakes, as well as your feet when you need to make an emergency stop.

Navigating curbs, loose paving stones, tree roots and narrow paths.

Practice your skills by gradually adding challenges:

Try gentle slopes up and down hill.

Practice using the handbrake.

Use your feet for braking.

Always stay in control.

Try navigating around obstacles on a flat surface.

Be sure to avoid leaning left when you turn right and vice versa to avoid tipping.

Slow down and use smaller steps when turning.

Always be aware of the balance point. The device will tip if a turn is taken too suddenly or at too high a speed.

Carefully navigate obstacles on a sloping surface.

Be very aware of the balance point on the Alinker.

It is best to pick a route that is directly uphill or downhill, not at a diagonal.

Take smaller steps so your feet are in almost constant contact with the ground for stability.

Practice getting over curbs.

Any obstacle like a curb needs to be approached at a 90 degree angle.

General remarks about the Alinker:

- At a higher speed than 3 mph, the function of the handbrake is limited. Please take note of this when you go faster than 3 mph, or if you are going downhill.
- Maladjustment or misuse may cause problems for the Alinker user. It is important that an Alinker user reports any trouble to the supplier and possibly make an appointment for a service call.
- Using the Alinker frame as a footrest, may cause problems. If an Alinker user puts a foot on the frame near the wheel, there is a risk that (1) the foot touches the spokes (especially with little feet or casual footwear) and (2) the foot slides off the frame, which may cause a balance problem or a fall. It is recommended to wear sturdy shoes.
- When un-folding the Alinker, avoid pinching your fingers in the hinge joint
- Remember to have fun!

You can always call us or schedule a skype call

+1 778 228 9618

SKYPE: TheAlinker

Warranty: see website <http://www.thealinker.com/pages/limited-warranty>



www.theAlinker.com