

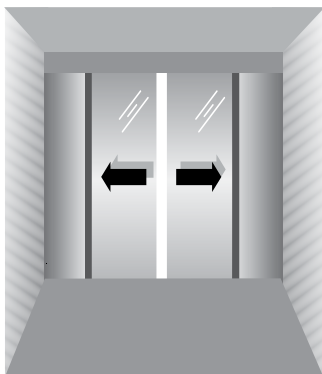

Omgivelseskontroll
Dokumentasjon for Dørautomatikk
Picomatic 2101
(Tormax 2101 for omgivelseskontroll)



Instructions for Use

For Automatic Sliding Doors with Drive

TORMAX 2101 Sliding Door Drive



Safety instructions in chapter 2 must be observed!

Contents

1	General Information	3
1.1	Target Groups	3
1.2	Storage and Forwarding of the Manual	3
1.3	Area of Application	3
1.4	Explanation of the Symbols	4
1.5	Technical Data	4
2	Safety	5
2.1	Responsibilities	5
2.2	Intended Use	5
2.3	Pre-conditions for the Operation of the System	5
2.4	Hazards and Risks	5
2.5	Checks	6
2.6	Decommissioning the System in the Event of a Fault	6
2.7	Disposal	7
3	Product Description	8
3.1	System Overview	8
3.2	System Function	9
3.3	Operating Modes	10
4	Operation	12
4.1	Commissioning	12
4.2	Operation with TORMAX User Interface	12
4.3	Operation with an Operating Mode Switch	13
4.4	Operation on Power Failure	13
5	Procedure in the Event of a Fault	14
5.1	Fault indication	14
5.1	System with Operating Mode Switch	15
6	Maintenance	16
6.1	Cleaning	16
6.2	Functional Checks	16
6.3	Maintenance and Testing	16
7	Appendix	17
7.1	Fault Table	17
7.2	Check-list for Functional Checks	18

First edition: 4.13, Update: 9.13, 4.14

We reserve the right to make technical changes.

Printed on environmentally friendly paper bleached without the use of chlorine.

Landert Motoren AG and Landert GmbH are certified to ISO 9001.

1 General Information

1.1 Target Groups

- Operator of the automatic sliding door. The operator is the person responsible for the operation and maintenance of the system.
- Persons instructed by the operator to carry out certain duties, for example the servicing and maintenance of the automatic sliding door.

1.2 Storage and Forwarding of the Manual

- Store the instructions for use in the vicinity of the automatic door system.
- If the manual has become illegible due to constant usage, reorder the instructions.
- When the door system is transferred or resold to a third party, pass the following documents to the new owner:
 - This instructions for use
 - Documentation concerning modification and repair work
 - Proof of the regular examinations → System test book T-879

1.3 Area of Application



Product name, door system: Automatic sliding door

Product name, door drive: **TORMAX 2101 Sliding Door Drive**

Serial number:

Identification plate:

The identification plate with the serial number is attached to the header section.

		Landert Motoren AG Unterweg 14 CH-8180 Bülach								
Model:										
DIN18650-1:2010		2	3	2	0	123	0	2	EN16005:2012	
Un:				IP		T _A				
Pmax.:		lmax.:		Pedestrian Door Operator				Serial No.:		
Pmin.:		lmin.:		Manufactured:						
Weight of door leaves:										

1.4 Explanation of the Symbols



Warning (signal word)

Source of hazard (designates a possibly hazardous situation)

Possible consequences of non-observance

- Measures for averting danger.

Text which is highlighted in grey MUST be observed to ensure that the system operates perfectly. Failure to observe these sections can cause damage to equipment.



Functions marked with this symbol are the factory setting. However, they can be reprogrammed by a specialist.



Optional components which are not present in all systems.

1.5 Technical Data

Drive type:	Electro-mechanical sliding door drive with DC motor
Control system:	Control unit 2101 MCU42-COU-A
Mains connection:	1 x 230/1 x 115VAC, 50 – 60Hz, 10 A
Power consumption:	max. 190 W
Motor:	24 V DC, 2,7 A
Sensor supply:	24 V DC, 0,75 A
Protective class, drive:	IP 20
Ambient temperature:	–20 °C to +50 °C
Noise emission level:	< 70 db(A)

2 Safety

2.1 Responsibilities

For instructing the operator:	A skilled person from a TORMAX sales partner
For operating the system:	The operator or a person instructed by the operator
For maintenance and function control:	The operator or a person instructed by the operator
For annual testing and approval:	A skilled person authorised by the manufacturer

Skilled persons are persons who have adequate knowledge in the field of power-operated doors as a result of their specialist training and experience and who are so familiar with the relevant health and safety regulations, guide-lines and generally recognised codes of practice that they are able to assess the condition of power-operated doors with regard to the safety of their operation.

Maintenance of electrical parts must be carried out by a trained electrician.

2.2 Intended Use

The automatic sliding door is intended exclusively for use in dry premises in areas used as a pedestrian thoroughfare. The manufacturer will not accept any liability whatsoever for loss or damage caused by improper use, failure to comply with the maintenance specification (see section 6) or unauthorised modification of the system.

2.3 Pre-conditions for the Operation of the System

The door system was designed, installed and checked for functionality and safety by skilled persons prior to hand-over to the operator. The company responsible for the system's installation instructed the operator on the system's use and maintenance as well dangers associated with the system operation. The operator has confirmed this by his signature in the system test book T-879.

The provisions imposed by law, health and safety and occupational health regulations for the avoidance of accidents and the protection of the environment which are generally applicable in the country in which the system is operated supplement the Instructions for use.

- Read the Instructions for use carefully before commissioning the automatic sliding door.
- Only use the system when it is in perfect working order. The operating conditions, inspection and maintenance intervals stipulated by the manufacturer must be observed (section 6).
- Safety facilities (e.g. sensor technology, manual unlocking) must not be removed or disabled.
- Arrange to have any faults rectified immediately by a skilled person.

2.4 Hazards and Risks

Depending on the system design and equipment, there is a residual risk of crushing, entanglement and collision in the movement area of the door leaves – albeit with restricted force.

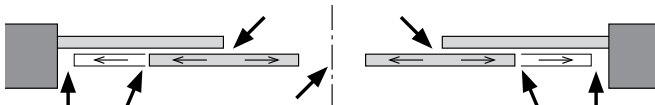



Warning

Danger through moving parts:

- in the area of all closing edges
- in the gap for suspending the door in the cladding
- when objects such as, for example, display shelves are erected in the direct proximity of the moving part of the door leaf.

Risk of injury

- Do not allow children to play in the direct proximity of the automatic door.
- Children may not operate the existing operating units.



Warning

Hazards can arise due to deliberate damage, incorrect installation, defective sensors or sensors which are longer properly adjusted, sharp edges, incorrectly mounted and defective casing or missing covers.

- Danger for body and life, danger of injury
- Have system repaired by a qualified person

2.5 Checks

The regular checks and examinations set out in Chapter 6 must be carried out as instructed by the manufacturer. The manufacturer recommends that a maintenance contract be concluded in order to operate the system safely and to maintain its value for as long as possible.

2.6 Decommissioning the System in the Event of a Fault

If there is a fault the automatic door may only be taken out of service by a skilled person, the operator or a person who is instructed to do so by the operator. This must be done on all occasions on which the safety of persons could be compromised.

- Disconnect the system from the power supply.
- Open the door manually and leave open if it is installed in an escape route.

See section 5 for rectification of faults.

2.7 Disposal

This system must be properly dismantled at the end of its working life. Its disposal must comply with national regulations. We recommend that you contact a skilled person disposal company.



Warning

Aggressive acids

Risk of injury if you dismantle the battery module.

- Dispose of batteries properly.



Warning

Broken glass

Risk of injury when dismantling the door leaves.

- Take care when transporting the door leaves.

3.2 System Function

It is the responsibility of the system operator to ensure that the automatic sliding door can be freely used at all times and particularly that access to the sliding door is not blocked.

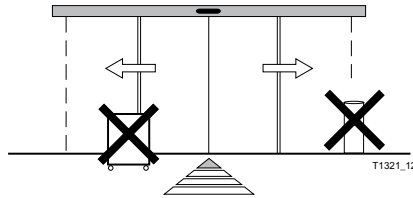

Automatic Door Operation with Sensors

When operating automatically (operating mode AUTO) the door is automatically opened from both sides by sensors when a person approaches.

A key switch ◆ or card reader ◆ normally allows access from outside when the door is in operating mode EXIT or OFF. The door unlocks, opens and closes again as soon as no further sensors are activated after a hold-open time of 5 s.

The sensors for the door opening and the maintained opening of the door are arranged and adjusted in such a way that the door opens promptly and remains open as long as a person is within the operating range of the door leaves. The door can close nevertheless but only after an attendance time of approx. > 1 minute.

The reduced closing speed which is set by the installer and is adjusted in line with the door weight, combined with a force of < 150 N prevents the impact of the moving leaves on a person from being too severe. The obstruction is also detected by the control system and the door automatically reverses.

Traffic Control

Movement through the door can be allowed in only one direction if desired (operating mode EXIT) or completely blocked (operating mode OFF).

In order to protect against environmental influences (wind/cold/heat) the door can be operated in operating mode AUTORED with a restricted opening width which is not less than the required escape route width.

Automatic System Monitoring

The control system monitors the safety sensors by a cycle of active tests. The control system also conducts continuous internal system tests. If a safety-related component should fail, the system automatically switches into a safe condition. At the same time the fault number is displayed on the user interface. You can find further information on this subject in section 5 "Procedure in the Event of Faults".

Electro-mechanical Lock ◆

The system can be locked in operating mode OFF by means of an electro-mechanical lock ◆.

In the event of a power failure the locks can also be directly activated by the optional manual facility.

Operation in the Event of a Power Failure

Depending on the equipment installed, the following functions are possible:

With 6V Battery Module ◆

- In operating mode AUTO: The door opens immediately and remains open.
- In operating mode OFF: The door remains closed if it was locked mechanically at the moment of power failure. Otherwise the door opens and remains open.
- When power is restored the door closes again and functions according to the set operating mode.

With Battery Unit ◆

- Continued operation of the system by means of a battery unit ◆ for a specific time with the doors opening before the battery switches off. The door remains locked in operating mode OFF.
- Unlocking and opening of the door from outside by means of a key switch and the battery unit ◆.
- When power is restored the door closes again and functions according to the set operating mode.

Without 6V Battery Module ◆ / Battery Unit ◆

- In operating mode AUTO or OPEN: The door stands still and is then freely movable.
- In operating mode OFF: The door remains locked if a lock is installed. Otherwise the door leaves are freely movable.
- When power is restored the door closes again and functions according to the set operating mode.

3.3 Operating Modes



Operating Mode OFF

The internal and external sensors are disregarded. The door is maintained in the closed position by the motor and/or locked by the electro-mechanical lock ◆. Access is only possible using the key switch ◆. The door can still be used for 10 seconds after selecting operating mode OFF from inside to out.



Operating Mode AUTO

The operating mode AUTO is normally used during the day. The door opens automatically to its full opening width to both sides by means of the internal and external sensors.



Operating Mode AUTORED

Operating mode AUTORED (Automatic Reduced) is normally used during the day. The door opens automatically (normally with a reduced opening width) to both sides by means of the internal and external sensors.



If required, the opening width and hold open time can be adjusted by the installer.



Operating Mode EXIT

Operating mode EXIT is normally used for the period before the shop or office closes. The door will only open automatically when activated by the internal sensor.

When the door opens the external sensor is also monitored for safety reasons.

The opening width is determined by previously selecting operating mode AUTO or AUTORED The door can be automatically blocked using the holding magnet ◆.

○ **Operating Mode OPEN**

The door opens and remains open. The opening width is determined by previously selecting operating mode AUTO or AUTORED

Operating Mode Manual Operation

The door leaves can be freely moved. This operating mode can be used for cleaning the door leaves and the floor guide or for temporarily shutting down the door. The system is reset after leaving this operating mode.

4 Operation

The automatic sliding door may only be operated by a skilled person, the operator or a person instructed by the operator.

4.1 Commissioning

Before switching on the mains power supply:

- Unlock the optional mechanical door lock e.g. floor lock.
- Check that the movement area of the door leaves is free from objects e.g. umbrella stands or vehicles.
- Check that the floor guide (particularly if it is continuous) is clean and not blocked by anything (e.g. gravel or snow).
- Switch on the mains power supply and select operating mode AUTO, for example.
- Wait until the door is closed.
 - The first movement after switching the power on for the first time is slow. The control system is checking the door leaf's travel distance and defining the end position.
 - The door is now ready for operation.

4.2 Operation with TORMAX User Interface ♦

TORMAX User Interface

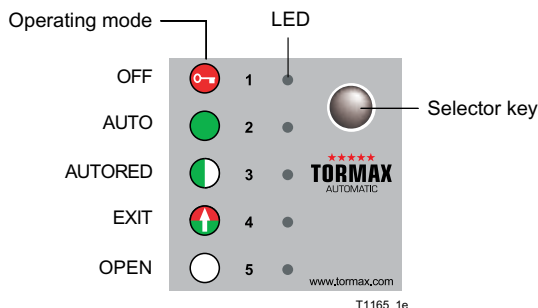

Lock ♦ for User Interface

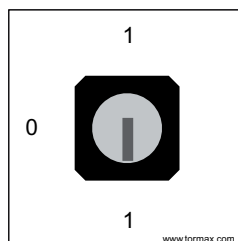

Selection of Operating Modes

- Release lock ♦ for user interface.
- Press selector key briefly. The corresponding operating mode symbol is illuminated.

Switching to manual operation

- Press the selector key and hold down for 5 seconds.
 - Manual operation is indicated by all five LEDs flashing.
- Press the selector key briefly to switch out of manual mode.

Fault indication

e.g. LED 4 flashes. See Section 5 for how to proceed in the event of faults and how to reset the system. See chapter 7 for the definition of the fault.

4.3 Operation with an Operating Mode Switch ◆

Selection of Operating Modes

The operating mode can be set directly.

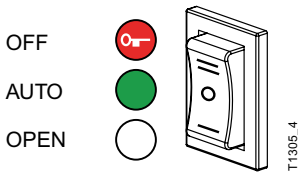

4.4 Operation on Power Failure

Manual Locking ◆

- Press the manual operation knob inwards.
- Push the door closed by hand until the latch engages.



Manual Unlocking ◆

- Pull the manual operation knob outwards.
- Push the door open by hand.

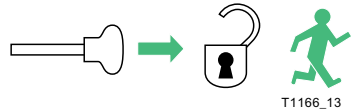

T1166_13

Opening a Door with a Battery Unit ◆ Using a Key Switch ◆

- Turn the key switch to the “on” position and hold in place for at least 5 seconds, then turn the key to the original position.

The key switch must not remain permanently in the “on” opposition.

- The battery is activated using the “wake up” function.
- The door is unlocked, opens, closes slowly and locks again.
- The battery remains switched on in AUTO, AUTORED, EXIT and OPEN until the battery charge is too low. The door opens before switching off.
- The battery switches off in OFF as soon as the door is closed for at least 10 s (and locked where appropriate).

5 Procedure in the Event of a Fault

Faults are evident through unusual behaviour by the door and/or are indicated by the flashing light-emitting diodes (LEDs). The display takes the form of either a single flashing LED or by "Manual operation" being indicated if the system was automatically shut down by the control unit or an emergency opening was triggered. In this case the fault number is indicated by the single LED that is not illuminated.

5.1 Fault indication

See the table in Section 7.1 for a summary of fault signals and possible means of rectification.

Example: Display of fault number 3

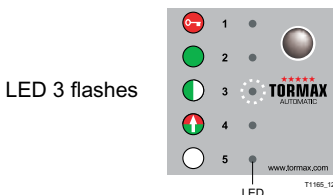

or →

All except LED 3 are flashing → The door system is in MANUAL OPERATION because of fault number 3

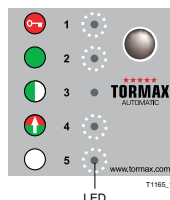

LED 3 flashes

Example: Display of fault number 5

All except LED 5 are flashing → The door system is in MANUAL OPERATION because of fault number 5

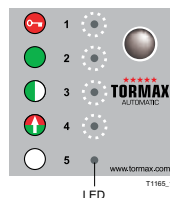

Restarting the Door System After a Fault (Software Reset)

Reset after a fault with the TORMAX user interface

Occasional faults can be rectified by re-starting the system.



- Press selector button and hold down for 5 seconds.
→ The door is in MANUAL OPERATION
- Press selector button briefly.
→ The software is reset.

Resetting after fault number 5



- Press selector key briefly
- Change operating mode
- Turn the key switch on and then off again quickly

The software is reset
→ manual operation is reset;
the door opens and closes slowly.

Reset of the Fault by Disconnecting the Power Supply

- If the system does not have a battery unit, disconnect from the power supply for about 10 seconds.

If this does not reset the fault or if it re-occurs after a short time, you must arrange for the fault to be rectified by a skilled person from your TORMAX dealer. In this case note the fault number and inform the dealer. See the last page or the service tag on the system for the dealer's address.

5.1 System with Operating Mode Switch

Faults are evident through unusual behaviour by the door or through a safety standstill. Thereafter the door leaves can only be moved manually.

Restarting the Door System After a Fault with Standstill

- Change operating mode.
- Turn the key switch on and then off again quickly.

Restarting the Door System After Unusual Behaviour

- If the system does not have a battery unit, disconnect from the power supply for about 10 seconds.
- If the system does have a battery unit, disconnect from the power supply and wait for the emergency opening.

A Software-Reset is being performed.

→ MANUAL OPERATION is reset, the door opens and closes slowly.

If this does not reset the fault or if it re-occurs after a short time, you must arrange for the fault to be rectified by a skilled person from your TORMAX dealer. See the last page or the service tag on the system for the dealer's address.

6 Maintenance

The system was tested and approved by an expert before initial commissioning. The manufacturer recommends that you conclude a service contract in order to maintain the value of your system for as long as possible as well as to ensure the system operates reliably and safely for a long time.

Only genuine TORMAX spare part should be used. The manufacturer accepts no liability if you fail to observe this requirement. Original spare parts and original accessories guarantee the safety of use in accordance with norm EN 16005.

The following maintenance work must be carried out:

6.1 Cleaning



Warning

Closing doors can crush – danger!

Trapped limbs can lead to serious injury.

- The system must only be cleaned in operating mode OFF, OPEN or Manual Operation.
- Clean casing parts, the user interface and door leaves with a damp cloth and a commercial cleaner.

6.2 Functional Checks

The operator must check the function and safety devices of the automatic sliding door at least every 3 months. This will ensure that faults or hazardous changes in the system are detected at an early stage. See section 7.2 “Check-list for Functional Checks” for items to be checked.

You should arrange for any defects detected during the routine checks to be rectified immediately by a TORMAX dealer (see the last page of this Manual for the address).



Warning

Potential switching malfunction in the automatic sliding door.

Potential hazards – injury caused by impact or crushing.

6.3 Maintenance and Testing

Maintenance and testing should only be carried out by a trained specialist following the manufacturer's instructions.

Maintenance Interval

The maintenance interval depends on the frequency of use but the system must be maintained at least once per year.

Scope of the Maintenance Work

The content of the maintenance work is specified by the manufacturer in an inspection list.

System Test Book



The test findings are recorded after the test in the system test book. The operator must keep it in a safe place.

7 Appendix

7.1 Fault Table

LED	Group of faults	Behaviour	Cause	Trouble shooting
1	Lock	<ul style="list-style-type: none"> • Door does not lock. • Door does not unlock and stays closed. 	<ul style="list-style-type: none"> • Lock latch stuck or defective. 	<ul style="list-style-type: none"> • Move lock latch manually. Free manual disengagement by turning button ccw for about 90 °. • If no success, or fault occurs repeatedly call TORMAX service.
2	Interface RS232 to user interface	<ul style="list-style-type: none"> • Operating mode cannot be changed. • No display on the user interface. 	<ul style="list-style-type: none"> • Connection from the control unit to the user interface interrupted 	<ul style="list-style-type: none"> • Call TORMAX service.
3	Safety facility	<ul style="list-style-type: none"> • Door remains open and closes slowly after 1 min. 	<ul style="list-style-type: none"> • Safety sensor has been active for more than 1 min, or safety test is negative. 	<ul style="list-style-type: none"> • Remove objects in the door passage. • If no success, or fault occurs repeatedly call TORMAX service.
4	Activators	<ul style="list-style-type: none"> • Door remains open. 	<ul style="list-style-type: none"> • Activator inside/outside or key switch has been active for more than 5 min. 	<ul style="list-style-type: none"> • Reset key switch. • If no success, or fault occurs repeatedly call TORMAX service.
5	System	<ul style="list-style-type: none"> • Door stops and leaves can be moved freely. 	<ul style="list-style-type: none"> • Internal system fault. 	<ul style="list-style-type: none"> • Change operating mode (= RESET). • Activate key switch briefly. • If no success, or fault occurs repeatedly call TORMAX service.
All	No fault	<ul style="list-style-type: none"> • Door stops and leaves can be moved freely. 	<ul style="list-style-type: none"> • Operating mode MANUAL OPERATION 	<ul style="list-style-type: none"> • Change operating mode
Nothing displayed		<ul style="list-style-type: none"> • No reaction of the door and leaves can be moved freely. 	<ul style="list-style-type: none"> • Mains supply interrupted. • Emergency power supply switched off. • Drive is overheated. 	<ul style="list-style-type: none"> • Switch on mains → main fuse • Wait for 15 min. till drive has cooled down. • If no success, call TORMAX service.

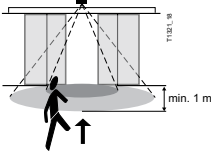
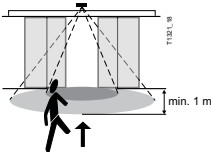
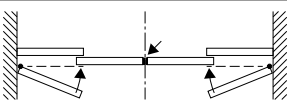
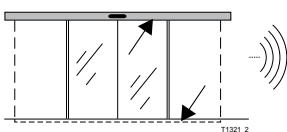
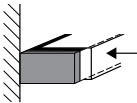
7.2 Check-list for Functional Checks

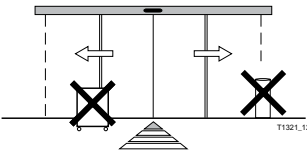
Item To Be Checked	Procedure	Result
Activating Sensors		
	<ul style="list-style-type: none"> Walk through the door directly from the front and from different directions at normal speed, starting both from the inside and outside. Activation min. 1 m from main closing edge. 	<p>The door opens at the right time and with sufficient speed so that passage through the door is not hindered.</p>
Safety Sensors (can be combined with activating sensors)		
	<ul style="list-style-type: none"> Walk through the door directly from the front and from different directions at a slow speed like an infirm person, starting both from the inside and outside. Activation min. 1 m from main closing edge. 	<p>The door opens and remains open until you are completely through the door.</p>
Moving Leaves, Side Parts, Fixed Leaves		
	<ul style="list-style-type: none"> Check the glass door fillings, door edges and rubber profiles for damage. 	<p>The door fillings have no sharp edges and splintered glass. The side parts and the door seals are in place and undamaged.</p>
Guide System and Door Guides		
	<ul style="list-style-type: none"> Check the noises made while the door moves. 	<p>No unusual and noticeable movement noises can be heard in the drive, guide system or floor guides.</p>
Cladding		
	<ul style="list-style-type: none"> Check whether the cladding is correctly slotted into place and secured. 	<p>The cladding is firmly slotted into place.</p>
Operating Controls		
	<ul style="list-style-type: none"> Check the function and marking of operating controls. 	<p>The operating controls are functioning correctly; the markings are visible and legible.</p>
System Vicinity		
	<ul style="list-style-type: none"> Check access to the door and the movement area of the door leaves. 	<p>Access to the door is free from objects and items likely to cause the user to trip. There are no objects such as shelves, plant containers and umbrella stands within a radius of 50 cm of the movement area.</p>



EG Declaration of Conformity

The manufacturer declares

Manufacturer's address: _____

that the product (machine)

Type designation: _____

Serial number: _____

is in conformity with the guideline EG-RL 2006/42/EG

is in conformity with regulations of the guidelines:

- 2006/95/EG (low tension)
- 2004/108/EG (electro-magnetic-compatibility)

and the following harmonised standards have been adhered to:

- EN 16005

Base document: Declaration of incorporation by TORMAX | Landert Motoren AG

Person responsible for documents

Name/address: _____

Place, date: _____

Signatory

(CE authorized person): _____

Signature: _____



the passion to drive doors

TORMAX Sliding Door Drives

TORMAX Swing Door Drives

TORMAX Folding Door Drives

TORMAX Revolving Door Drives

Manufacturer:

Advice, sales, installation
Repairs and service:

TORMAX | CH-8180 Bülach-Zürich

Phone +41 (0)44 863 51 11

Fax +41 (0)44 861 14 74

Homepage www.tormax.com

E-Mail info@tormax.com

TORMAX is a Division and a registered trademark of Landert Motoren AG

T-1675 e	Installation on Site	 TORMAX CH-8180 Bülach www.tormax.com info@tormax.com
Area of application	TORMAX 2101 Sliding Door Drive	
Release	15 April 2013	
Use	Installation, Maintenance	

Contents



1	Installation	1
1.1	Installation Variants	1
1.2	Installation of Header Profiles	2
1.3	Installation of the Sliding Leaves	3
2	Mechanical Adjustments	4
2.1	Aligning the Sliding Leaves	4
2.2	Adjusting the Counter Rollers	4
2.3	Checking the Grounding	4
2.4	Adjusting the Lock Clearance	5
2.5	Adjusting the Manual Disengagement	6
2.6	Holding Strip for Cladding	6
3	Checking the System	6

1 Installation

1.1 Installation Variants

Install the system respecting the installation alternatives and using the corresponding dimensional drawings. It is imperative to respect these drawings, to ensure a correct assembly and a safe function of the system.

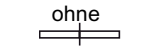
Installation on Lintel

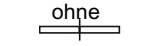
Profile	Fixed Leaf	Dimensional Drawings		
		EB	ER	EL
LR 12	mit 	T3-390-0501	T3-390-0507	T3-390-0504
	ohne 	T3-390-0500	T3-390-0506	T3-390-0503
LR 22B	mit 	T3-390-0521	T3-390-0527	T3-390-0524
	ohne 	T3-390-0520	T3-390-0526	T3-390-0523



Prior to installation respect the safety regulations according to the document T-1243 Safety during installation.

1.2 Installation of Header Profiles

Precondition

- The drive components have been pre-installed according to the instructions in T-1674, components assembly. Likewise the components can be installed after the installation of the header profile.

Use fastening screws with countersunk head for countersink dimensions $\varnothing 13 \times 90^\circ$, e.g.:

- Countersunk screw with six-lobe recess M6-ISO 14581
- Countersunk chip-board screw with six-lobe recess $\varnothing 6$
- The screw head must not protrude
- Adapt the fastening method to the base material

Standard Profile Set

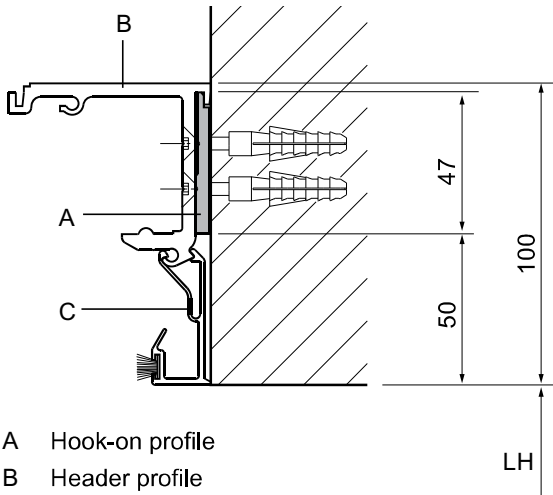

Header Profile H100

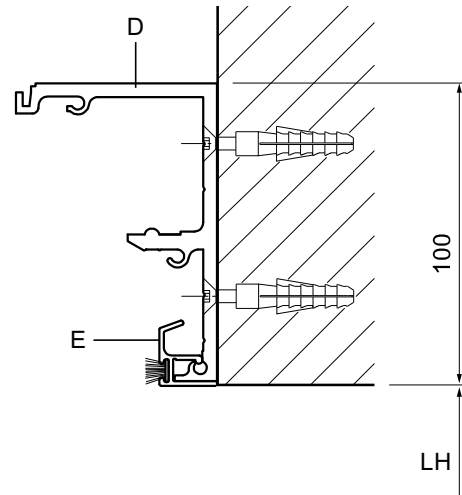

- A Hook-on profile
- B Header profile
- C Cable profile
- D Header profile H100
- E Cover profile

Installation hook-on profile for standard profile set

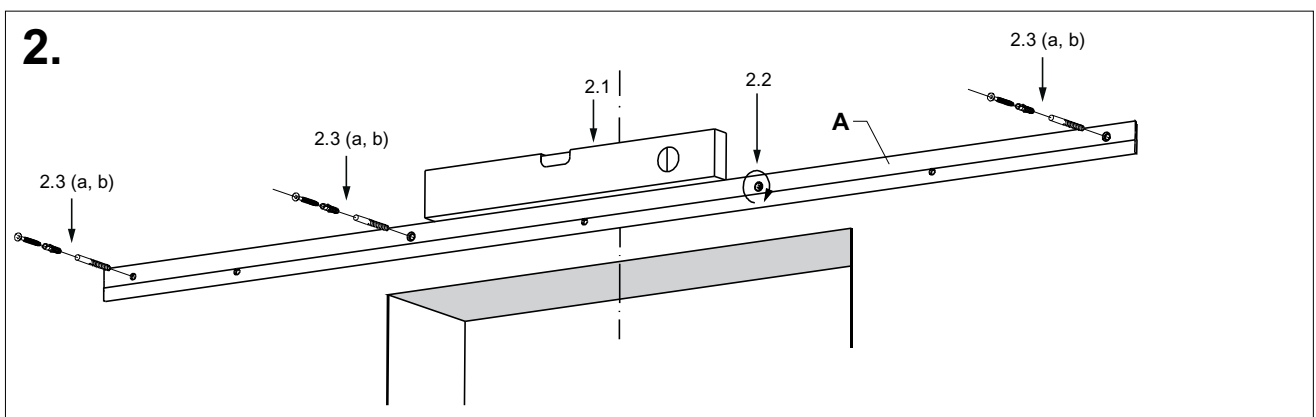
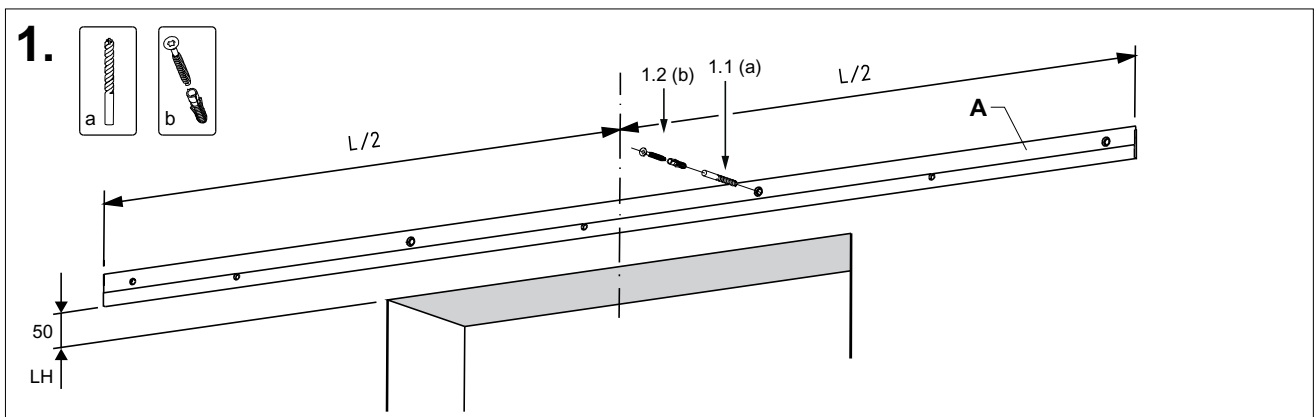

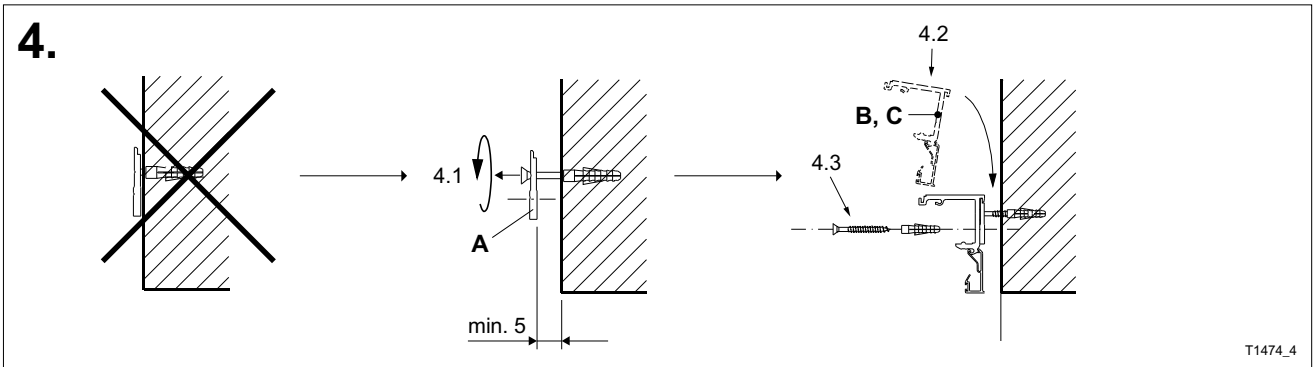
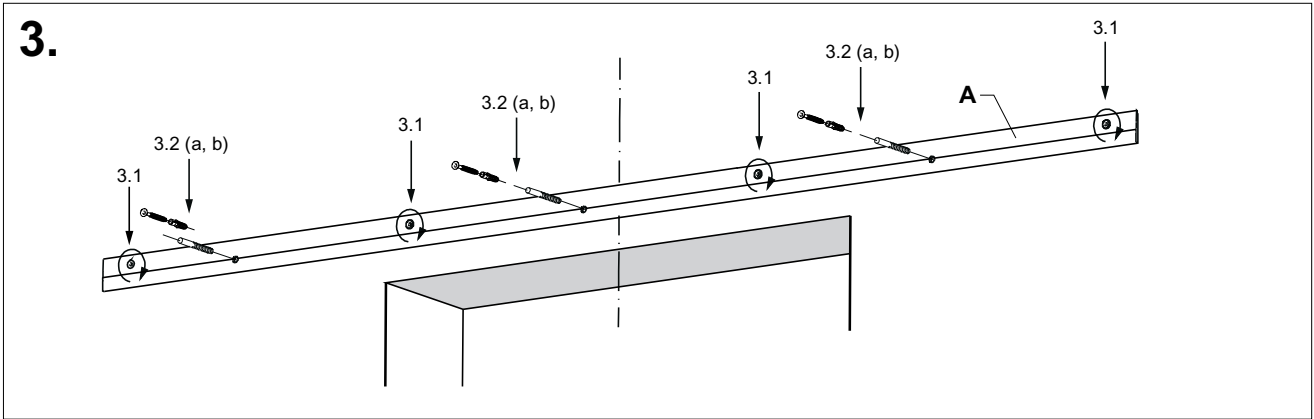

Adaption of Installation Surface

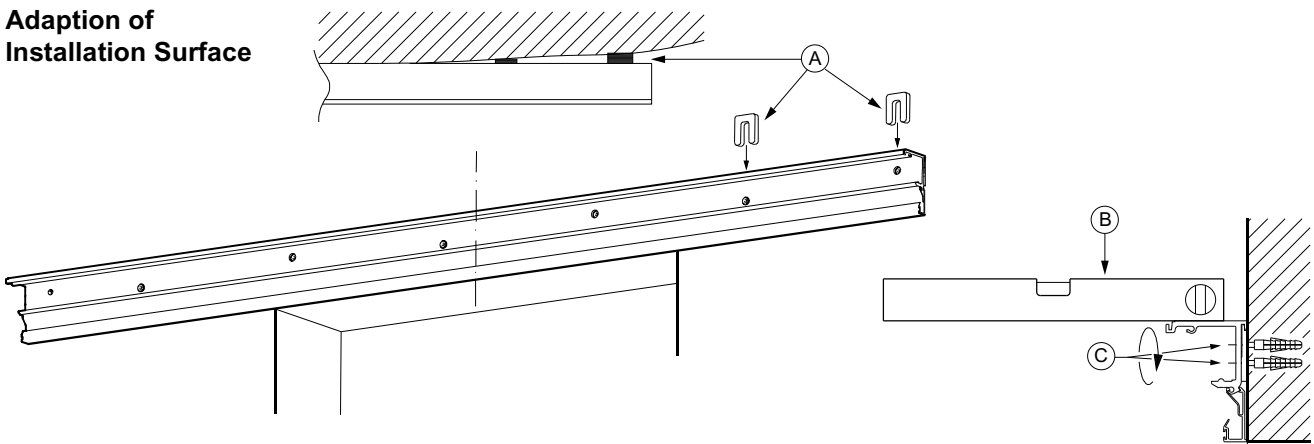

T1675_1

1.3 Installation of the Sliding Leaves

Important: If a lock is used, the dimensions 98 mm ±1 mm for EB, 127±1 mm for ER / EL must be observed.

Ideally, use door leaves with relocatable fastening positions.



Depending upon leaf weight an auxiliary person must be available for the installation.

For Dimension c see T-1677 Drive System Dimension.

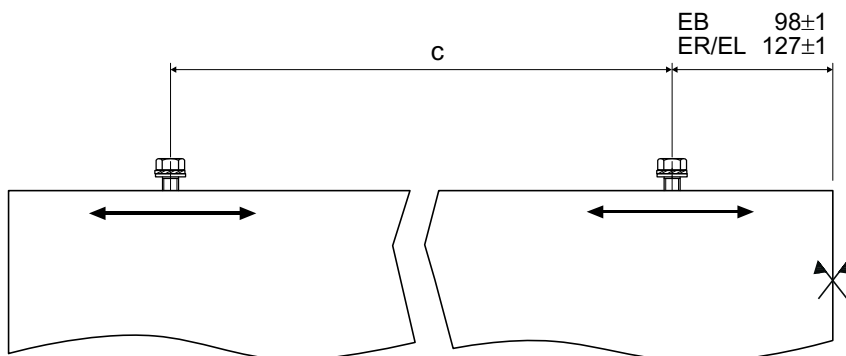

T1474_9

2 Mechanical Adjustments

2.1 Aligning the Sliding Leaves

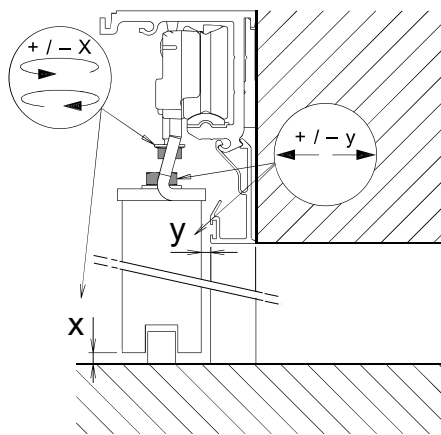

T1474_10

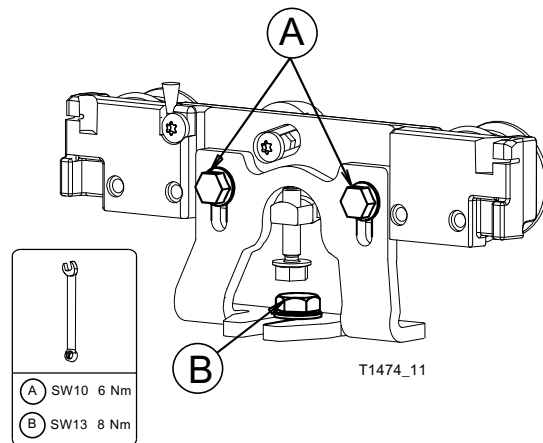

T1474_11

2.2 Adjusting the Counter Rollers

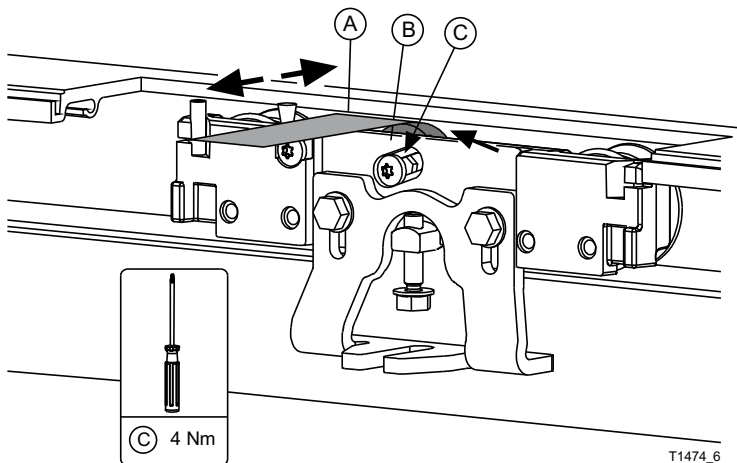

T1474_6

2.3 Checking the Grounding

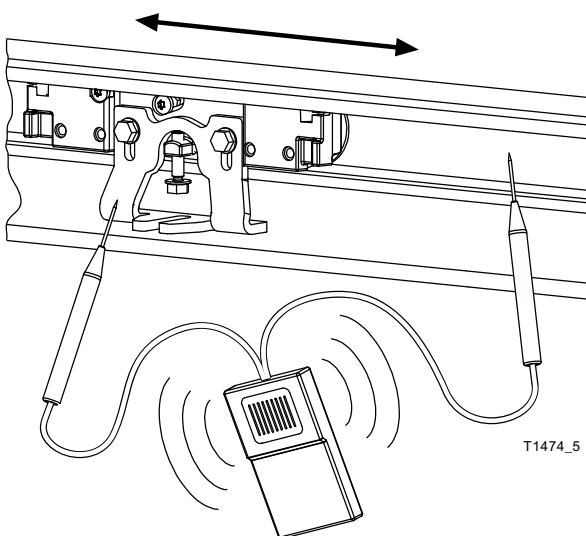

T1474_5

2.4 Adjusting the Lock Clearance

EB

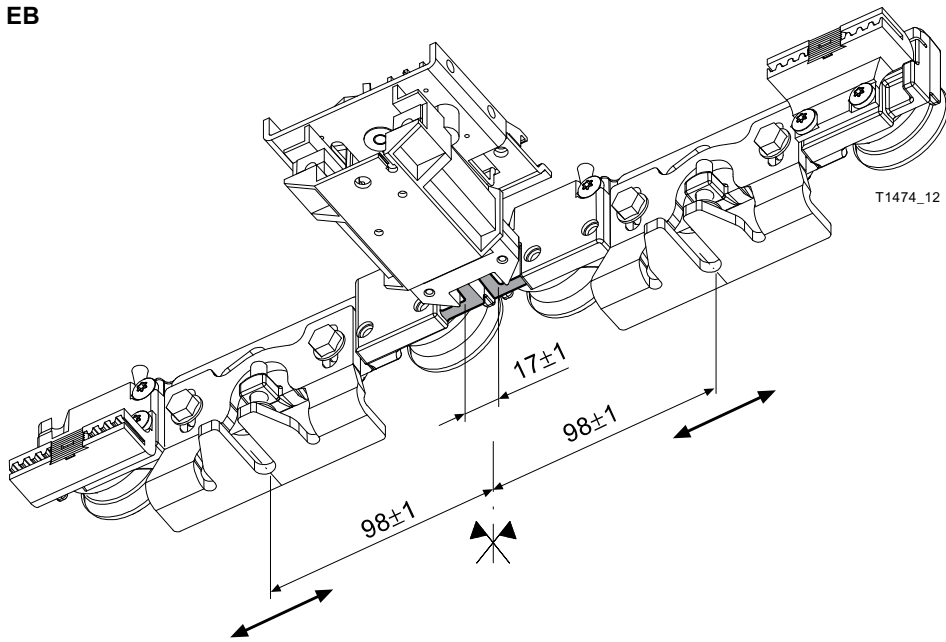

ER / EL

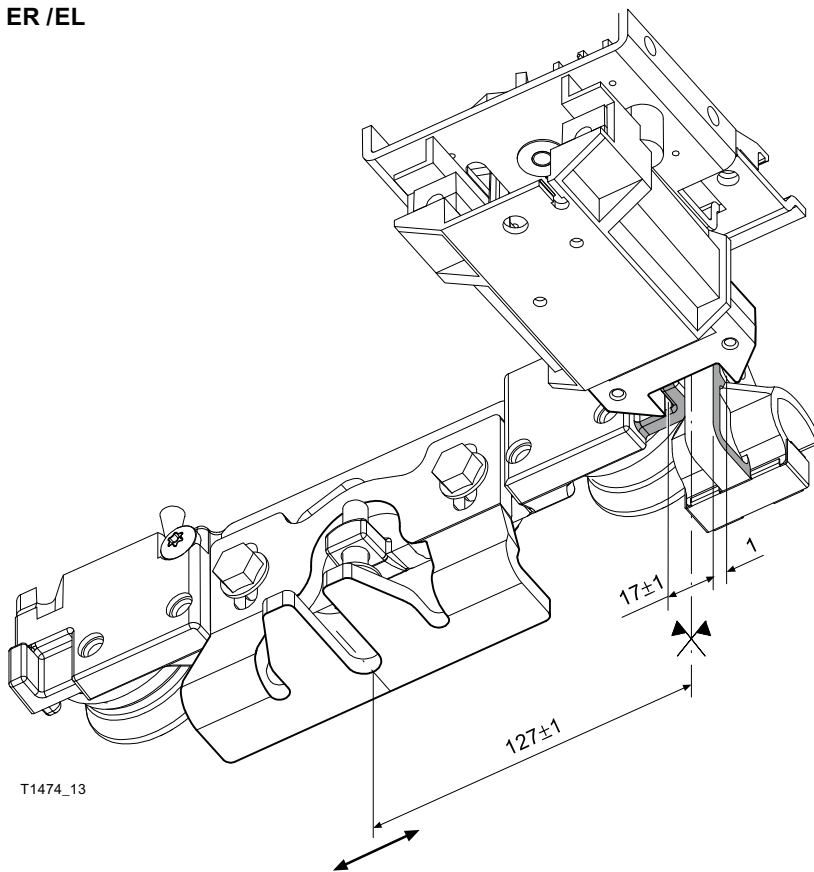

2.5 Adjusting the Manual Disengagement ◆

EB

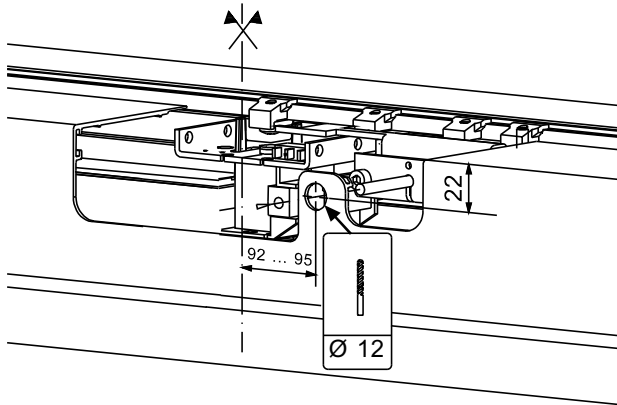

ER

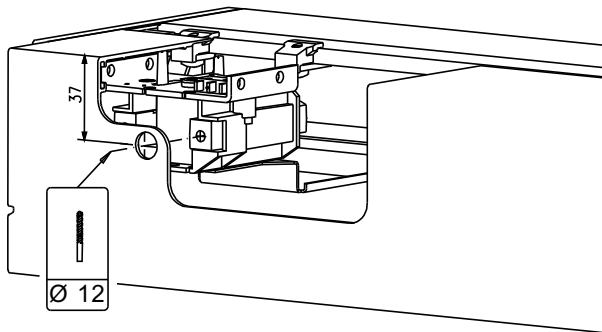

EL

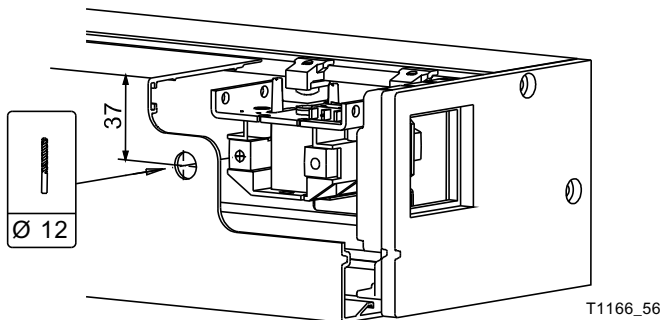

T1166_56

2.6 Holding Strip for Cladding

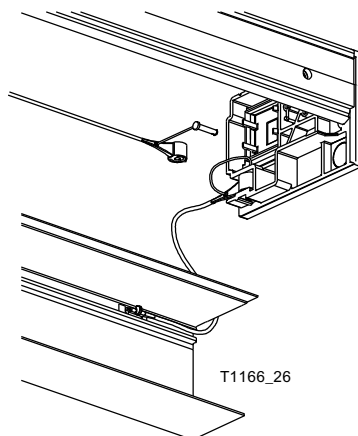

T1166_26

3 Checking the System



Before handing over to the user, the system must be checked according to the document T-1280 Examining the System and according to the checklist for first check 2201 on the TORMAX Extranet.