





# DECLARATION OF CONFORMITY



The manufacturer

**Neatech.it**

Via A. de Curtis 4/A, 80040, Cercola (NA), Italy

declares that

**the wheelchair XTREME  
(reference code: S065)  
other names: SPEEDSTAR XTREME**

satisfies the requirements laid down by the European Directive 93/42;  
according to the criteria for classification of Annex IX of this Directive, it is classified as:

**class I medical device**

It also complies with the requirement of the harmonized standards:

UNI EN 12182 – Technical aids for disabled person

ISO 7176-14:2008 - Power and control systems for electrically powered wheelchairs and scooters — Requirements and test methods

ISO 7176-21:2009 - Requirements and test methods for electromagnetic compatibility of electrically powered wheelchairs and scooters, and battery chargers

# Index

1	PRODUCT INFORMATION .....	1
2	PREPARATION FOR FIRST USE .....	2
2.1	Checks to be made on delivery .....	2
2.2	Unpacking .....	2
2.1	Software description .....	3
2.1.1	Rnet system: OBP onboard programming.....	4
2.1.2	Rnet system: PC programming.....	5
3	ADJUSTMENTS .....	7
3.1	List of adjustments .....	7
3.2	Seat tilt.....	8
3.3	Seat depth.....	9
3.4	Backrest angle.....	11
3.5	Footplates height.....	13
3.6	Footplates depth and angle.....	16
3.7	Armrest height.....	18
3.8	Armrest depth .....	20
3.9	Armrest depth .....	22
3.10	Castor height .....	24
3.11	Legrest angle .....	25
3.12	Joystick position .....	26
3.13	Default position.....	28
4	USE OF THE PRODUCT .....	29
4.1	Control system of the wheelchair .....	34
4.1.1	Rnet 80 A control system .....	34
4.2	Manual brake release lever .....	36
4.3	Use as seat in a motor vehicle.....	37
4.4	Main switch .....	38
4.5	Battery charging .....	39
4.6	Transport and storage .....	41
4.7	Transport and storage .....	42

4.8	Transport and storage .....	43
4.8.1	Batteries removal .....	44
5	MAINTENANCE .....	47
5.1	Maintenance and cleaning .....	47
5.2	Controls to be performed on the product.....	48
5.3	Tire puncture .....	49
5.3.1	User information .....	49
5.3.1	Service information .....	51
5.4	Wiring diagram .....	52
5.4.1	Rnet.....	52
5.5	Batteries replacement.....	56
5.6	Reuse .....	60
5.7	Spare parts.....	61
6	SPECIFICATIONS .....	65
6.1	Maximum user weight.....	66
6.2	Other provided information .....	67
6.3	Dimensions .....	69
	Dimensions : 1100 mm .....	69
	Dimensions : 980 mm .....	69
	Dimensions : 1070 mm .....	69
7	WARRANTY TERMS .....	70
7.1	Serial number .....	70

## Symbols in this manual



### **WARNING**

This symbol means presence of danger for the user or damage for the product. Always follow instructions when this symbol is present.



### **PINCH HAZARD**

This symbol means presence of pinch hazard.

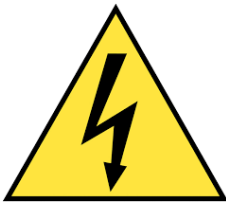

### **ELECTRICAL WARNING**

This symbol means presence of danger related to the presence of electrical energy. Please pay special attention when this symbol is present.



### **INFORMATION**

This symbol means general information intended to simplify or best explain the use of the product.



### **CONTACT INFORMATION**

This symbol means the need of contacting an authorized service center or the manufacturer.



### **TEMPERATURE**

The temperature of some surfaces may increase when the product is exposed to external heat sources as direct sunlight.



### **TIPPING HAZARD**

Tipping hazard is strongly reduced because of the design of the product according to EN 12182.

In any case, please pay special attention during the adjustments and use of the product to prevent any damage to the user or product itself.

**Any transport on a slope greater than the maximum safety slope can be dangerous.**

**Please don't seat on armrests.**



Center of balance of the wheelchair and so its stability can be affected by:

- User position
- Use of a backpack
- Tilting of the seat



### **PINCH HAZARD**

Make sure your feet do not hang up or get caught in the space between the footrests. In general, make sure you have proper space in areas you will travel through to minimize pinching or entrapment of body parts.

## ELECTROMAGNETIC RADIATION DANGER

The behavior of the wheelchair while driving may be affected by electromagnetic fields created by transceivers such as: Citizens band (CB) radios, walkie-talkies, fire and police radios, cellular phones, lap-top computers, commercial radio and television broadcast antennas. PLEASE USE CAUTION in the presence of these devices.

Electromagnetic radiation can cause your chair, without warning, to:

- release its brakes
- move by itself
- move in unintended directions

If any of these occur, it could result in severe injury to you or others. Electromagnetic radiation can damage the control system of your chair. There is no way to know the effect on electromagnetic immunity if you add accessories or modify this chair. Any change to your chair may increase the risk related to electromagnetic radiation. Parts from other suppliers have unknown electromagnetic properties. **The wheelchair might disturb the operation of devices in its environment.**

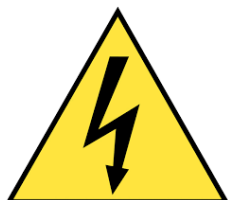

## INFORMATION

For information on how to obtain information and instructions in a format appropriate for use by visually impaired people please contact the manufacturer.



Service manual is intended for technical personnel to maintain and repair wheelchairs. It is important to follow the instructions contained in this manual in order to professionally work with the product.

The qualified personnel who works with wheelchairs must comply with all provisions of occupational safety and common sense in order to preserve his own safety.

The manufacturer declines all responsibility for any accidents occurring during the working with the product.

**WARNING: It is prohibited to use the product or its parts for any purpose other than that indicated. For a correct use please follow the instructions given in this manual. The manufacturer disclaims any responsibility for damages caused by improper use of the product.**

The manufacturer disclaims any responsibility for inappropriate selection of product model and configuration.

Information in this manual may be subject to change without notice. All information, pictures and specifications are based on the product details that were available at the time of preparation of this document. They are representative examples and they are not intended to be exactly as the actual product.

#### **MODIFICATIONS**

**Any unauthorized modification to the product may increase the risk of personal injury and damage to the product itself. All modifications should be done by an authorized service center.**

**Do not use any unauthorized accessories or spare parts on the product. Do not use the product in combination with other medical devices without first having considered any risk due to combination of more products.**

#### **MANUFACTURER**

For any need not expressly explained in this manual, please contact the manufacturer.

#### **Neatech.it SRL**

via A. de Curtis 4/A, 80040, Cercola (NA), Italy

[www.neatech.it](http://www.neatech.it) – [info@neatech.it](mailto:info@neatech.it) - +39 081 555 1946

#### **INCIDENT REPORTING**

**If an incident occurs, please contact an authorized service center. For a list of authorized service center please contact the manufacturer.**



#### **DISPOSING**

This product and all its components can not be treated as household waste. For more detailed information on how recycling and disposal this product contact your local waste disposal service.

# 1 PRODUCT INFORMATION

The Xtreme is a lightweight power wheelchair, handy and extremely powerful, developed to maximize the athlete's skills in wheelchairs. The cambered wheels and the low center of gravity gives it stability and extreme maneuverability, giving it a sporty souls and a precision of outstanding leadership.

The Xtreme is equipped with fully programmable performance modules in order to meet all driving needs of each athlete, in any role and any arrangement.

Control, power (350 watt motors), speed (up to 15 km/h) and stability with 7.5° camber wheels make the Xtreme one of the most agile and performing chair in its category. The modular structure of the seat allows the positioning of the user in the most appropriate way.

<b>Total wheelchair weight</b>	MAX 105 kg
<b>Maximum user weight</b>	MAX 150 kg
<b>Seat width</b>	MIN 360 mm – MAX 500 mm
<b>Batteries</b>	2x 12 V 75 Ah / 2x 12 V 50 Ah
<b>Charger</b>	68A
<b>Power module</b>	Rnet 120 A
<b>Motors</b>	2x 220 W

## 2 PREPARATION FOR FIRST USE

### 2.1 Checks to be made on delivery

- Check for the integrity of the original packaging.
- Check for any anomalies on shipping documents.
- Check for the functionality and integrity of the device in all its parts, at the time of delivery or immediately thereafter, to ensure that no damage has resulted from a careless transport.
- Make sure the surface of the device is not damaged, scratched, bent, etc.
- Any fault or damage found must be immediately reported on the shipping documents and promptly communicated to the shipper.

### 2.2 Unpacking

Inside the box there are:

- Xtreme wheelchair
- Documents and manual
- Charger

The wheelchair is delivered already mounted and ready to use. Before starting to use the wheelchair please check if all described components are present. **If not, please contact as soon as possible the vendor.**



#### PACKAGING DISPOSAL

To properly recycle the packaging materials follow instructions provided by your local waste disposal service.

## 2.1 Software description

The software of the wheelchair can be categorized into these classes:

- Kernel software of power module.

**There is no required access, modification or customization of this part of the software**



**In case a reprogramming of the wheelchair is required, please contact the manufacturer to have instructions and the most suitable version of the software.**

**In case of problems with this part of the software please contact the manufacturer.**

- Software parameters of the wheelchair.

This part of the software is made by the manufacturer. It is intended to assure driving and seating function of the wheelchair. It is responsibility of the manufacturer to correct program parameters regarding the structure of the wheelchair.

Qualified personnel of an authorized service center are able to customize this part of the software to best fulfill single user requirements.



**Programming must be conducted only by qualified personnel with in-depth knowledge of the wheelchair and power module system.**  
**Any change to this part of the software may result in a hazardous situation for the user.**

### 2.1.1 Rnet system: OBP onboard programming

Onboard programming allows the wheelchair to be programmed via the Joystick Module. Turn off the wheelchair. Insert the Rnet dongle along the communication cables in the system. Turn on the control system. After initialization, reboot the wheelchair. Press the Mode key until the OBP screen is reached. **For more information, see Rnet manual.**



**Programming must be conducted only by qualified personnel with in-depth knowledge of the wheelchair and power module system.**  
**Any change to this part of the software may result in a hazardous situation for the user.**



To manage this part of the software it is required a Rnet Dongle made by Penny & Giles and some special software.  
Please contact the manufacturer for more information.

## 2.1.2 Rnet system: PC programming



**Programming must be conducted only by qualified personnel with in-depth knowledge of the wheelchair and power module system. Any change to this part of the software may result in a hazardous situation for the user.**



To manage this part of the software it is required a Rnet Dongle made by Penny & Giles and some special software.  
Please contact the manufacturer for more information.



To know the latest version of wheelchair parameters and for more information please contact the manufacturer.

### Software setup

[SKIP THIS POINT IF YOU ALREADY INSTALLED THE LATEST VERSION OF RNET SOFTWARE OEM\_GENERIC]



To know the latest version of RNET software please contact the manufacturer.

Please lunch setup application and follow showed indications.

## Programming the wheelchair - Drive parameters

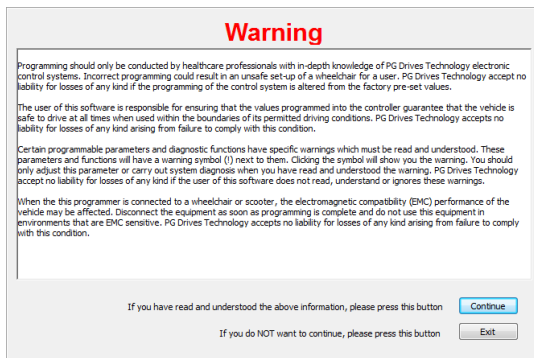

**Figure 1**

- Start the application PG DRIVES TECHNOLOGIES >> R NET PROGRAMMER >> OEM GENERIC >> PROGRAMMER
- Click CONTINUE to actually start the application.

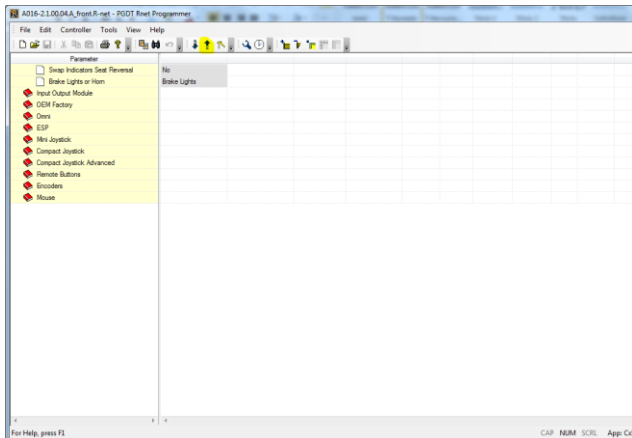

**Figure 2**

- Click FILE>>OPEN and select the desired programming file or read parameters from the wheelchair by clicking on the DOWN arrow.
- **Connect the Rnet Dongle to the PC and to the wheelchair. For more information, see Rnet manual.**
- Customize desired parameters.
- When finished turn on the wheelchair and click on the UP arrow to write the parameters in the wheelchair.



## 3 ADJUSTMENTS

### 3.1 List of adjustments

Type of operation	
A	Operation intended to be performed by the user.
B	Operation intended to be performed by an assistant.
C	Operation intended to be performed by an authorized service center.

Table 1

Adjustment	Type of operation
Seat tilt	A - User
Seat depth	B - Assistant
Backrest angle	B - Assistant
Armrests depth and width	B - Assistant
Armrests height	B - Assistant
Castor height	B - Assistant
Front protection	B - Assistant
Footplates height	B - Assistant
Footplates angle and depth	B - Assistant
Joystick position	B - Assistant
Stick depth	B - Assistant

Table 2

### 3.2 Seat tilt

(A) SEAT ANGLE	(A) MIN VALUE	(A) MAX VALUE
	0°	15°

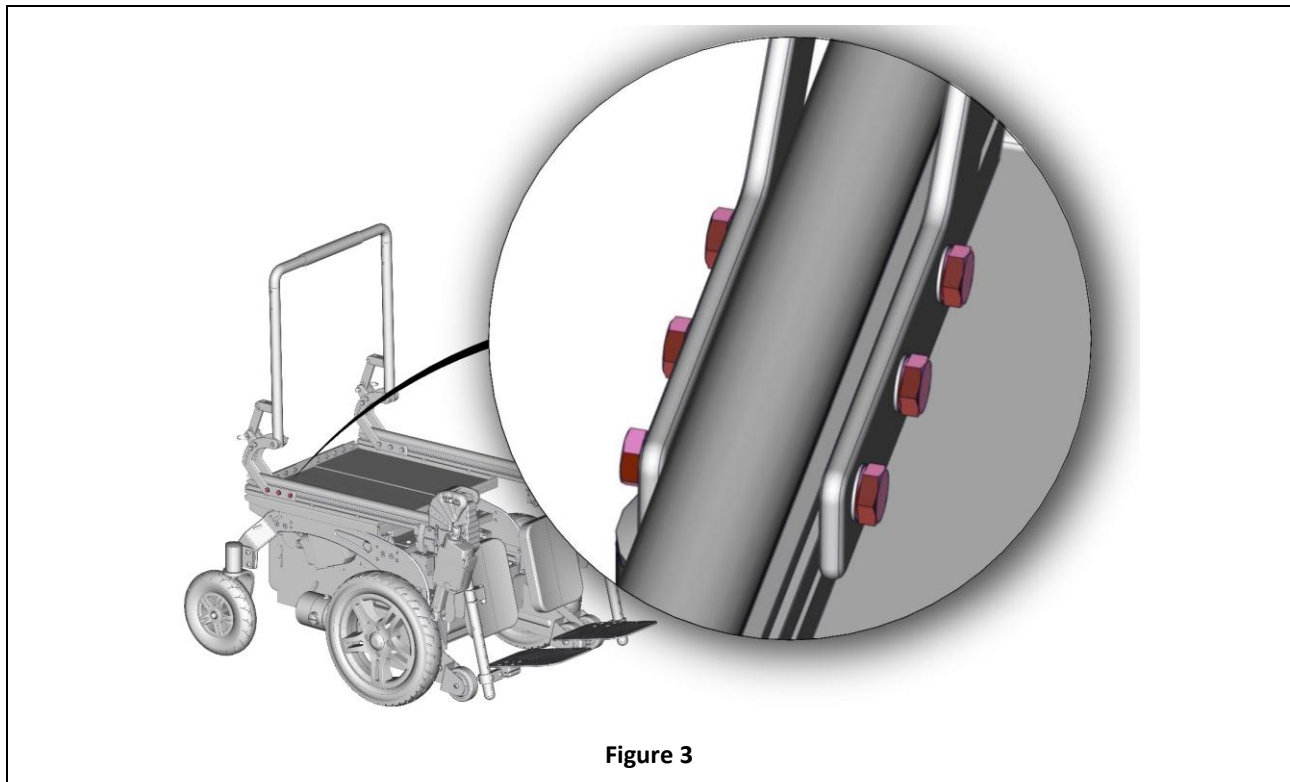

- Act on the lever (A) located under the seat to tilt the wheelchair.

### 3.3 Seat depth

	(A) MIN VALUE	(A) MAX VALUE
	340 mm	460 mm

Table 3



#### WARNING

It is needed to set separately left and right seat depth. Always set them at the same manner.

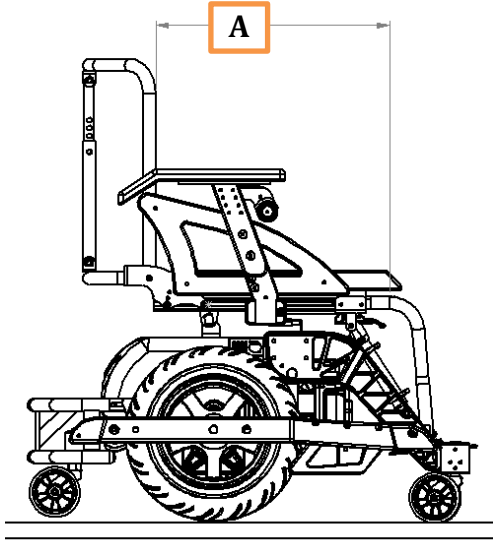

**Average needed time:**

5 min



**Difficulty level:**

Easy

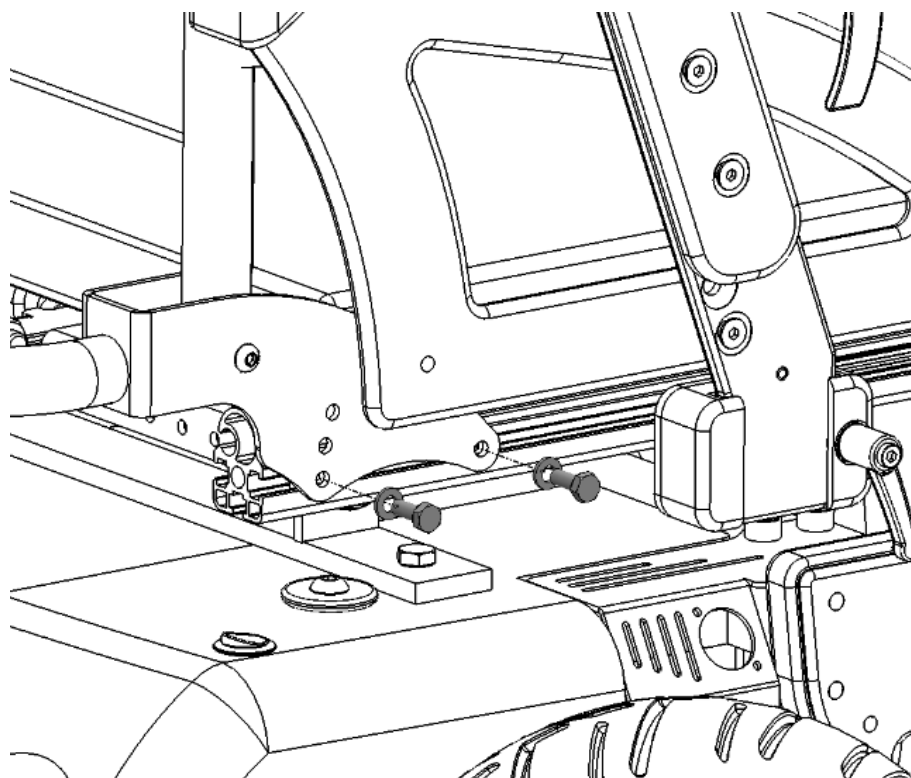

Figure 4

- Remove the backrest.
- Loosen the 2 screws shown in figure.
- Set the backrest according to the desired seat depth.
- Tight again the 6 screws.
- Repeat operations for both left and right side of the wheelchair.
- Mount again the backrest.



**OPEN-END WRENCH**

10 mm



### 3.4 Backrest angle

<b>(A)</b> <b>BACKREST ANGLE</b>	<b>(A)</b> <b>POSSIBLE VALUES</b>
	80° 90° 99° 108° 117° 126° 135°

	<b>Average needed time:</b> <5 min		<b>Difficulty level:</b> Easy
---	---------------------------------------	--	----------------------------------

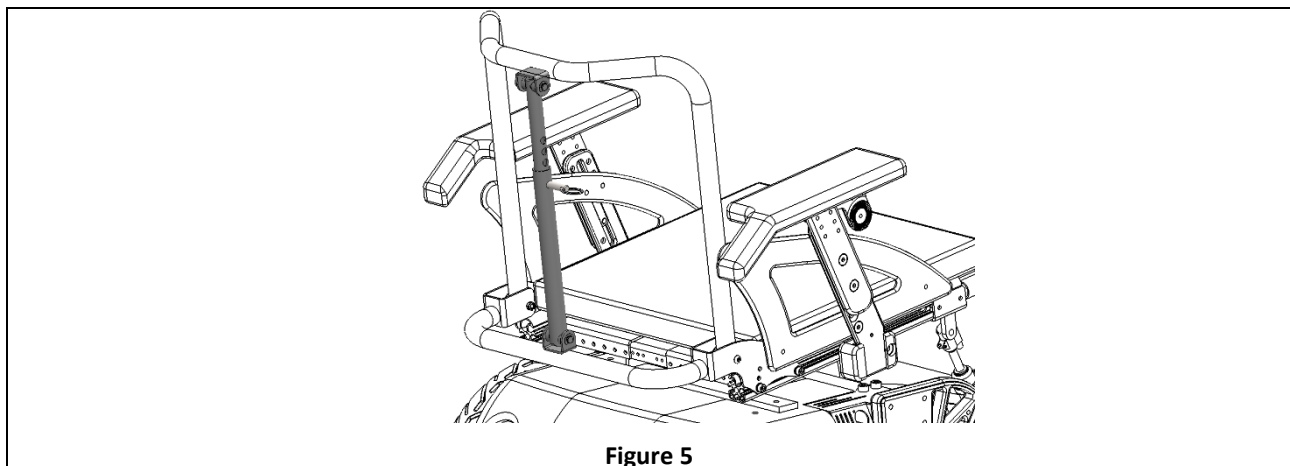

<ul style="list-style-type: none"> <li>• Pull away the pin shown in figure</li> <li>• Set backrest at the desired angle</li> <li>• Put back in place the pin in one of available holes.</li> </ul>	<b>OPEN-END WRENCH</b> 	10 mm
--	---	-------

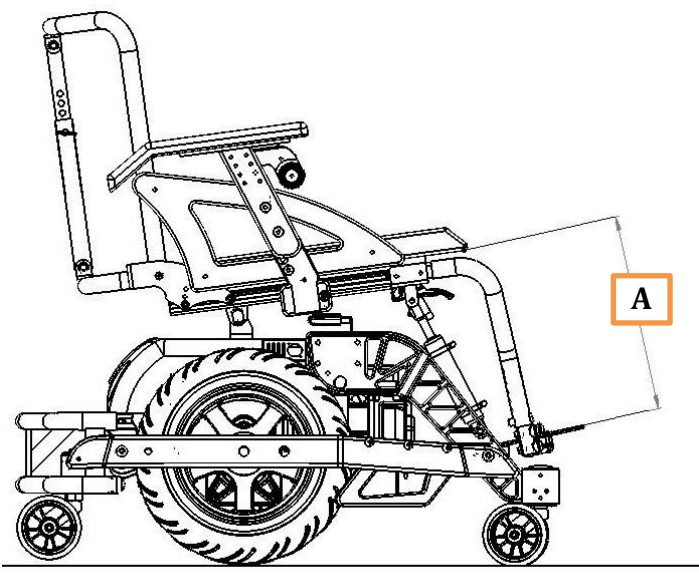

### 3.5 Footplates height

	<b>(A)</b> <b>POSSIBLE VALUES</b>
	30.0 cm 31.5 cm 33.0 cm 34.5 cm 36.0 cm



**Average needed time:**  
<5 min



**Difficulty level:**  
Easy

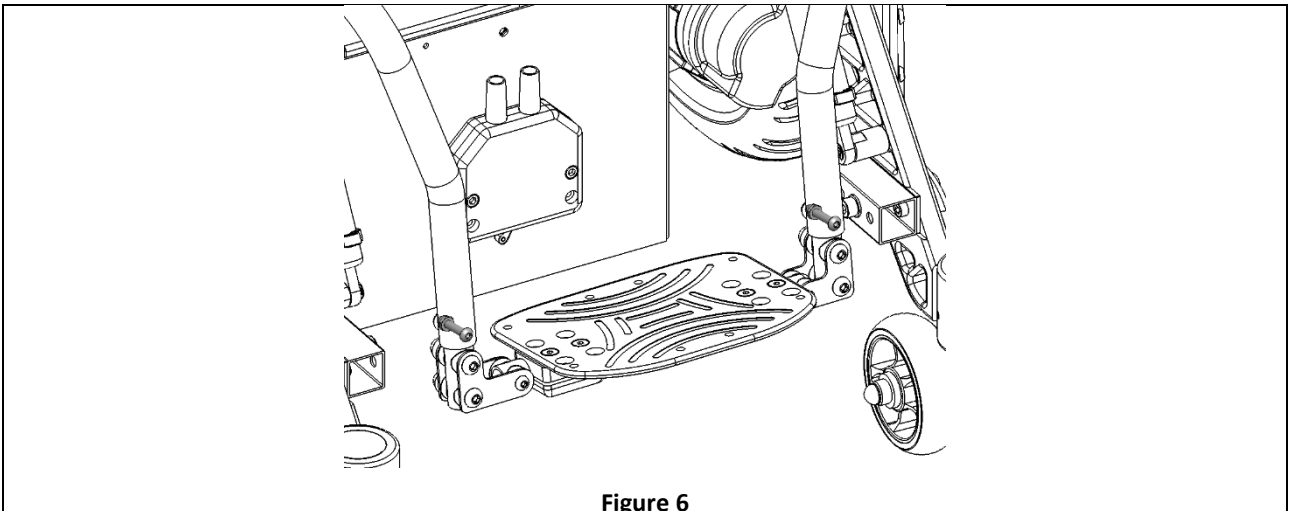

**Figure 6**

- Unscrew the screw shown in figure with the allen wrench while holding the nut behind with the open-end wrench.
- Repeat the operation for both left and right side of the wheelchair.
- Set the position of the footplate according to desired height.
- Screw again the screws.

**ALLEN WRENCH**



4 mm

**OPEN-END WRENCH**



10 mm



## Central mounted legrest

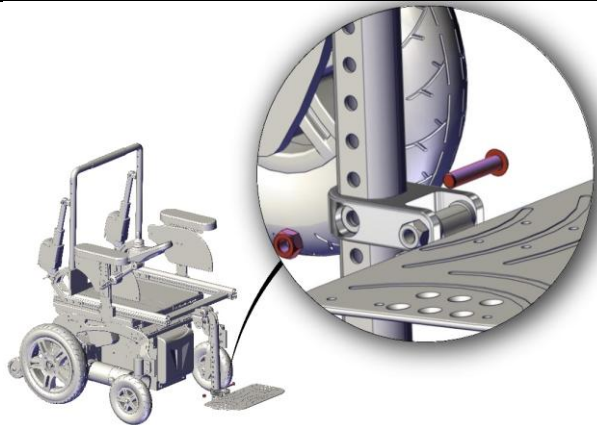

Figure 7

- Unscrew the screw shown in figure with the allen wrench while holding the nut behind with the open-end wrench.
- Set the position of the footplate according to desired height.
- Screw again the screws.

### ALLEN WRENCH



5 mm

### OPEN-END WRENCH



13 mm

### 3.6 Footplates depth and angle



**RANGE**

It is not easy to provide a range for adjustment of footrests because there are too many configuration and possibilities. In any case it is always possible to choose between 3 different depth.



**Average needed time:**

<5 min



**Difficulty level:**

Easy

## Angle adjustment

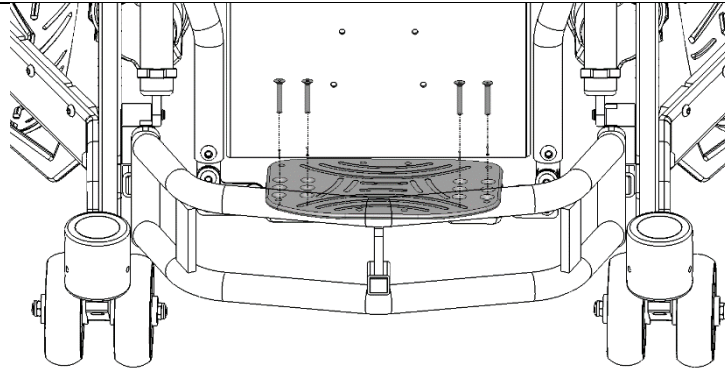

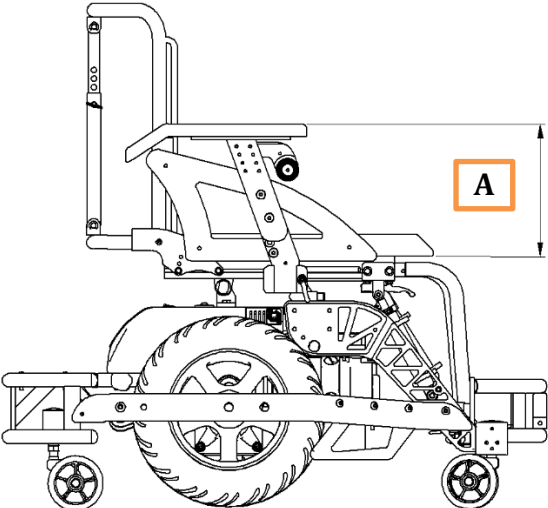

Figure 8

<p><b><u>Angle adjustment</u></b></p> <ul style="list-style-type: none"><li>• Loosen the 2 screws shown in figure.</li><li>• Set the position of the footplate according to desired angle.</li><li>• Tighten again the screws.</li></ul>	<p><b>ALLEN WRENCH</b></p>  <p>4 mm</p>
<p><b><u>Depth adjustment</u></b></p> <ul style="list-style-type: none"><li>• Unscrew the 2 screws shown in figure.</li><li>• Set the position of the footplate according to desired depth.</li><li>• Screw again the screws.</li></ul>	<p><b>ALLEN WRENCH</b></p>  <p>4 mm</p>

### 3.7 Armrest height

	(A) MIN VALUE	(A) MAX VALUE
		23.5 cm



#### RIGHT AND LEFT SIDE

It is possible to adjust separately left and right armrest.



**Average needed time:**

<5 min



**Difficulty level:**

Easy



#### SIDEPAD, JOYSTICK AND ARMREST HEIGHT

It is better to adjust first armrest height, then joystick and finally the sidepad.

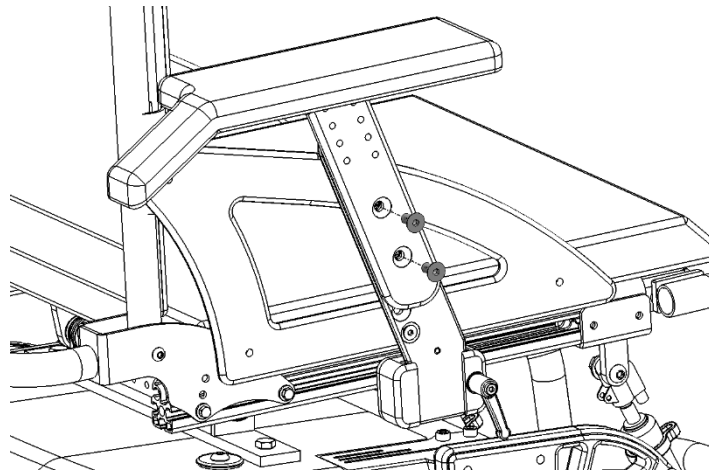

Figure 9

- Loosen the 2 screws shown in figure.
- Set the armrest according to the desired height.
- Tight again the 2 screws.

**ALLEN WRENCH**



5 mm

### 3.8 Armrest depth

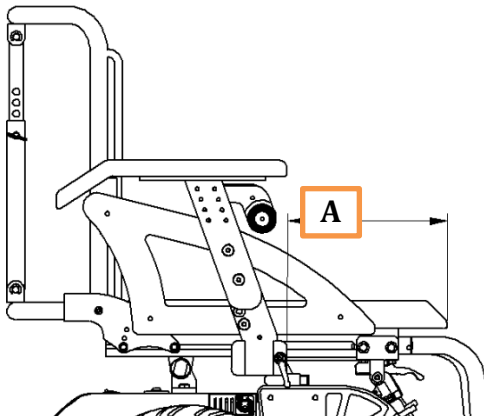
	(A) MIN VALUE	(A) MAX VALUE
	12.5 cm	23.5 cm



#### RIGHT AND LEFT SIDE

It is possible to adjust separately left and right side.



**Average needed  
time:**

<5 min



**Difficulty level:**

Easy

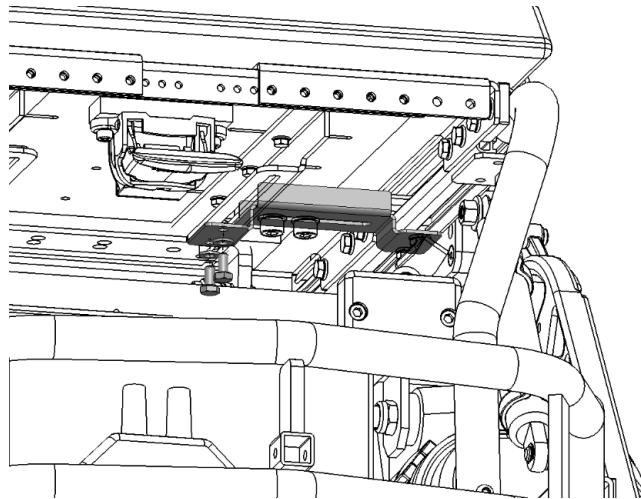

**Figure 10**

- Tilt the seat because it is needed to act under the seat. See section 3.2.
- Loosen the 4 screws shown in figure.
- Put the backrest at the desired position.
- Tighten again the 2 screws.

**OPEN-END  
WRENCH**

10 mm



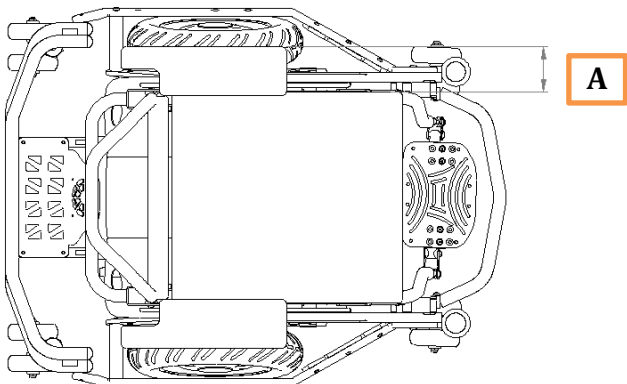

### 3.9 Armrest width

	(A) MIN VALUE	(A) MAX VALUE
	6.0 cm	10.0 cm



**RIGHT AND LEFT SIDE**

It is possible to adjust separately left and right side.

 <p><b><u>Average time:</u></b> needed &lt;5 min</p>	 <p><b><u>Difficulty level:</u></b> Easy</p>
--	---



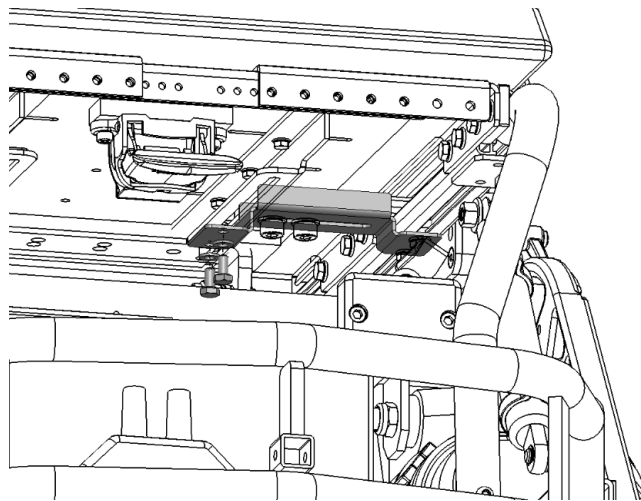

**Figure 11**

- Tilt the seat because it is needed to act under the seat. See section 3.2
- Loosen the 4 screws shown in figure.
- Put the backrest at the desired position.
- Tighten again the 2 screws.

**ALLEN WRENCH**



6 mm

### 3.10 Castor height



#### RANGE

It is not easy to provide a range for adjustment of sidepad because there are too many configuration and possibilities.



**Average needed time:**  
<5 min



**Difficulty level:**  
Easy

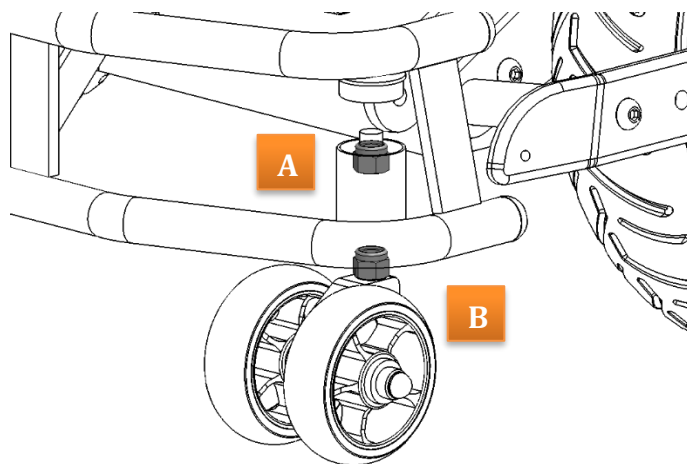

Figure 12

- Remove the plastic cup using a lever.
- Act on the two nuts shown in figure to adjust the height of the castor.

OPEN-END  
WRENCH

19 mm



OPEN-END  
WRENCH

19 mm



### 3.11 Front protection



#### RANGE

It is not easy to provide a range for adjustment of sidepad because there are too many configuration and possibilities.

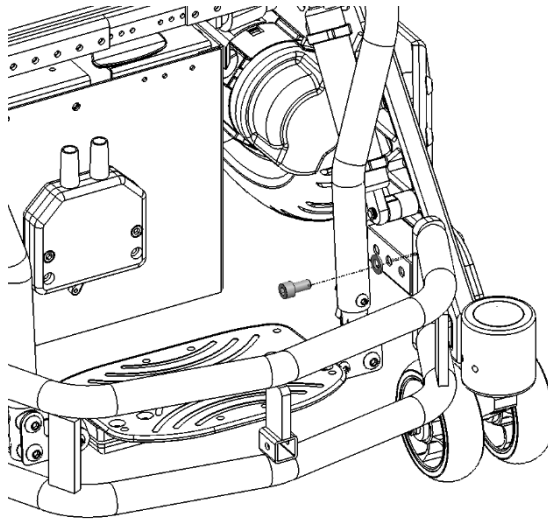

Figure 13

- Unscrew the screw shown in figure.
- Repeat operation for both left and right side of the wheelchair.
- Set the protection at the desired position.
- Screw again the screw shown in figure.
- Repeat operation for both left and right side of the wheelchair.

ALLEN WRENCH



6 mm

### 3.12 Joystick position



#### RANGE

It is not easy to provide a range for this because there are too many configuration and possibilities.



#### Average needed time:

<5 min



#### Difficulty level:

Easy

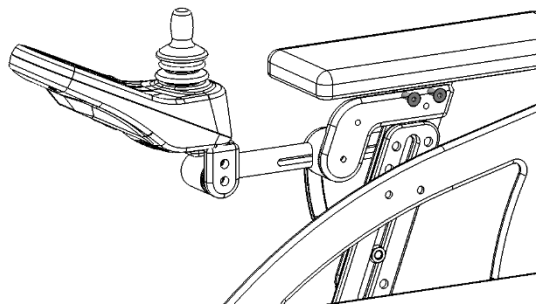

Figure 14

- Unscrew the 2 screws shown in figure.
- Adjust the depth of the joystick as desired.
- Screw again the screws.

#### ALLEN WRENCH



5 mm

### ADJUNCTIVE ADJUSTMENT

Moreover it is possible to adjust the angle of the joystick simply acting on the two levers shown in figure.

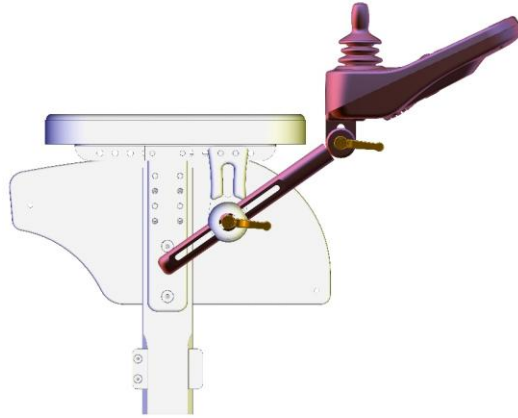

Figure 15

### 3.13 Default position

Default position means that all adjustable parts of the wheelchair are set in the most stable and safe configuration

ADJUSTABLE PARTS	VALUE	NOTES
Seat angle	0°	
Backrest angle	90°	
Legrest angle	90°	Or minimum
Seat height	0 cm	

Table 4

## 4 USE OF THE PRODUCT



### WARNING

Do not operate the wheelchair if it is behaving abnormally or erratically.  
The wheelchair may come to a sudden stop at any time during operation.



### WARNING

Do not stand on the product. Always use caution when transferring in or out of the seat. Every precaution should be taken to reduce the transfer distance. Also be certain the wheel locks are engaged to prevent the wheels from moving.

Do not let children use the wheelchair without supervision.



### INFORMATION

The product is not intended to be dismantled. There are no parts of the product expected to be handled during normal use of it



### INFORMATION

Do not install, maintain or operate the product without reading all warnings and this entire manual.

Always keep this manual in connection with the product.



### INFORMATION

The wheelchair is designed for use mostly in indoor environments.



### DRIVE WITH SEATING SYSTEM NOT IN DEFAULT POSITION

Seat tilt, backrest recline or legrest elevation may varies the center of gravity of the system wheelchair + user and increase tipping risk.  
Always drive at low speed when the seating system is not in the standard position and use powered seating functions only on a flat horizontal surface.



### WARNING

Do not carry passengers on the wheelchair independently of the age of the passenger. The wheelchair is not designed for weight training and is unsafe for use as a seat while weight training. Do not lean over the top of the back upholstery to reach objects from behind as this may cause the wheelchair to tip over. Do not shift your weight or sitting position toward the direction you are reaching as the wheelchair may tip over. Do not stand on the frame of the wheelchair.

**Some pathologies may limit your ability to use your wheelchair safely. Be sure to consult with a doctor about your physical limitations.**

Please practice your drive ability under the supervision of an assistant.



## Dealing with uphill

The wheelchair is intended to be used during sport competition. So it is not explicitly designed to deal with uphill. Please pay special attention when dealing with uphill.

## Dealing with downhill

The wheelchair is intended to be used during sport competition. So it is not explicitly designed to deal with downhill. Please pay special attention when dealing with downhill.



### WARNING

Don't use the wheelchair up or down slopes with a gradient than indicated in specifications of this manual.

Don't use the wheelchair up or down ramps that are not equipped with proper edge protection to prevent the wheelchair from falling down.

Don't use the wheelchair down or up a hazardous incline if the surface is covered with snow, ice or the surface is uneven.



### WARNING

The stopping distance on slopes can be significantly greater than on level ground

## Dealing with side slopes

The wheelchair is intended to be used during sport competition. So it is not explicitly designed to deal with side slopes. Please pay special attention when dealing with side slopes.

## Turning with the wheelchair

When turning with the wheelchair, always use great caution.

## Obstacle climbing

Wheelchair is not intended to climb obstacles. In any case when facing a small obstacle is it possible to unlock the rear protection acting on the handles shown in figure in order to facilitate operations. After obstacle climbing it is very important to lock again the rear protection.

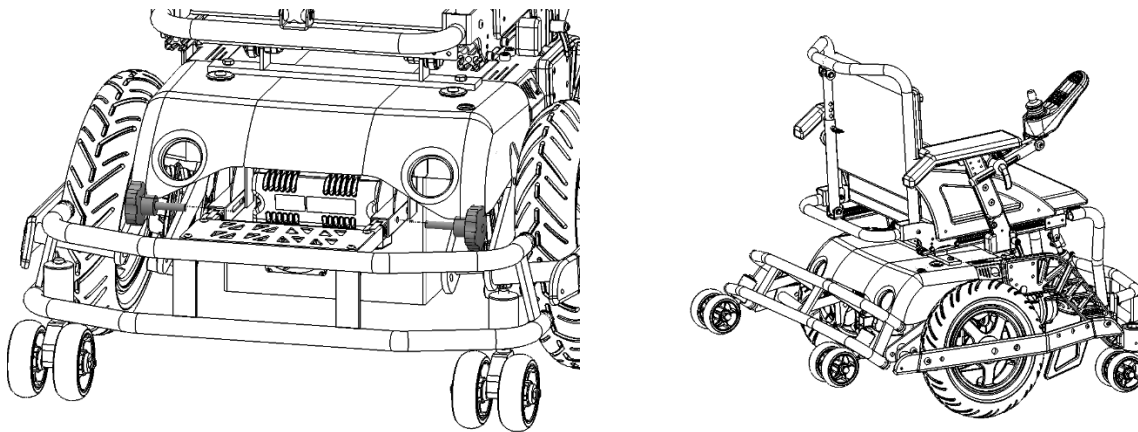

Figure 16

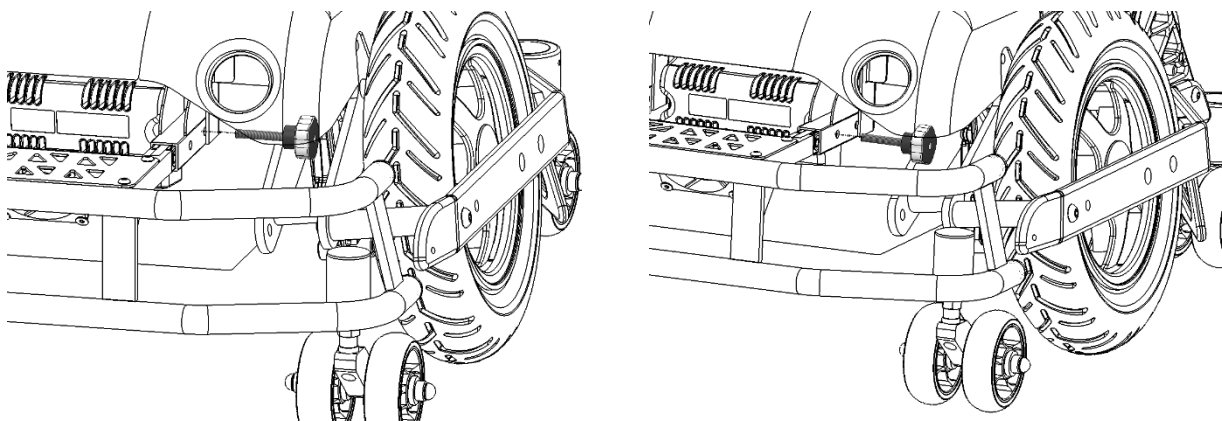

Figure 17

### **Driving in dark environments**

Don't use the wheelchair in dark environments without lights turned on.

### **Pelvic belt**

The wheelchair has the predisposition for a pelvic belt. **Pelvic belt is only design to position the user and not for any protection in case of accident.**

### **Transfer into and out the wheelchair**

Users transfer is recommended with the presence of an assistant. Don't use footrests or armrests as support. Always turn off the wheelchair before transfer.

### **Lift of the wheelchair**

Do not lift the wheelchair with a user on board. Do not lift the wheelchair grabbing the legrests. If you really need to lift the wheelchair, it is suggested to grab it with the help of at least one other people. Grab the wheelchair using the parts shown in figure.

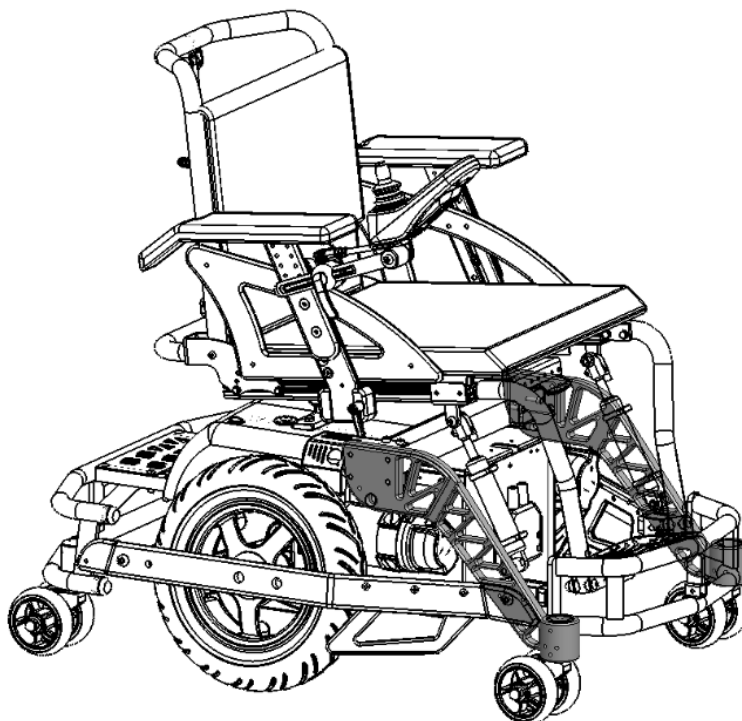

**Figure 18**

## 4.1 Control system of the wheelchair

It is possible to have the wheelchair with VR2 60 A control system or Rnet 80 A control system.

### 4.1.1 Rnet 80 A control system



Figure 19

FUNCTION	DESCRIPTION
<b>On-Off</b>	Use this function to turn on and off the wheelchair. Don't use this function to stop the wheelchair unless it is an emergency.
<b>Horn</b>	
<b>MODE</b>	Use this function to navigate all working mode of the wheelchair. For example it is possible to choose between drive and seat function.
<b>PROFILE</b> <b>Speed increase/decrease</b>	As default in the wheelchair they are saved some different drive profile for the use indoor and outdoor. Use the function PROFILE to change different types of profiles: they are sorted from the more indoor ones to the more outdoor ones. For each profile it is possible to change the speed.

Activate at the same time the functions to increase and decrease speed to enter a configuration menu.

<b>FUNCTION</b>	<b>DESCRIPTION</b>
<b>Set time</b>	Use this function to set the time shown on the display.
<b>Distance</b>	Use this function to see total and partial distance made with the wheelchair. It is also possible to reset partial distance.
<b>Backlight</b>	It is possible to adjust backlights of the screen.
<b>Background</b>	Use this function to choose the color of background of the display.

## 4.2 Manual brake release lever

In case of necessity it is possible to manually move the wheelchair.

First of all, you have to turn off the wheelchair.

Then you can act on the release levers shown in Figure.

When the brakes are released, it is not possible to drive the wheelchair.

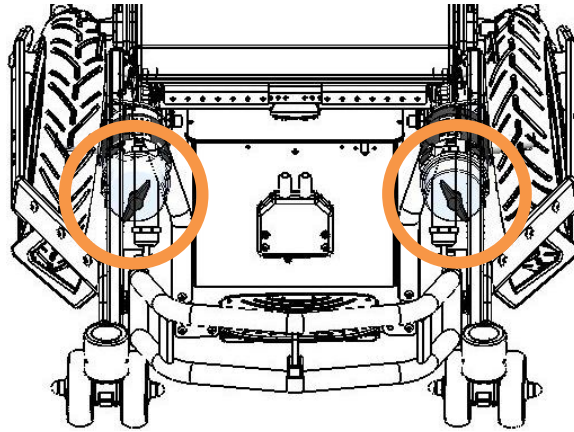
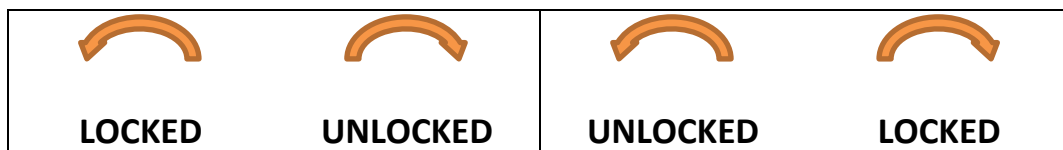

Figure 20



### WARNING

When the brakes are released never use the wheelchair on a slope or a wet surface.

Don't operate the brake release without the presence of an assistant.



### WARNING

The drive system should be re-engaged before an occupant is left unattended or attempts to operate the wheelchair.



### WARNING

Always act on both left and right manual release levers.

### 4.3 Use as seat in a motor vehicle



#### **WARNING**

It is not possible to use the wheelchair as a seat in a motor vehicle.

## 4.4 Main switch

Use the main switch to connect and disconnect the batteries from the power module. The switch also has the function of protecting the wheelchair from overloaded current and short circuit.

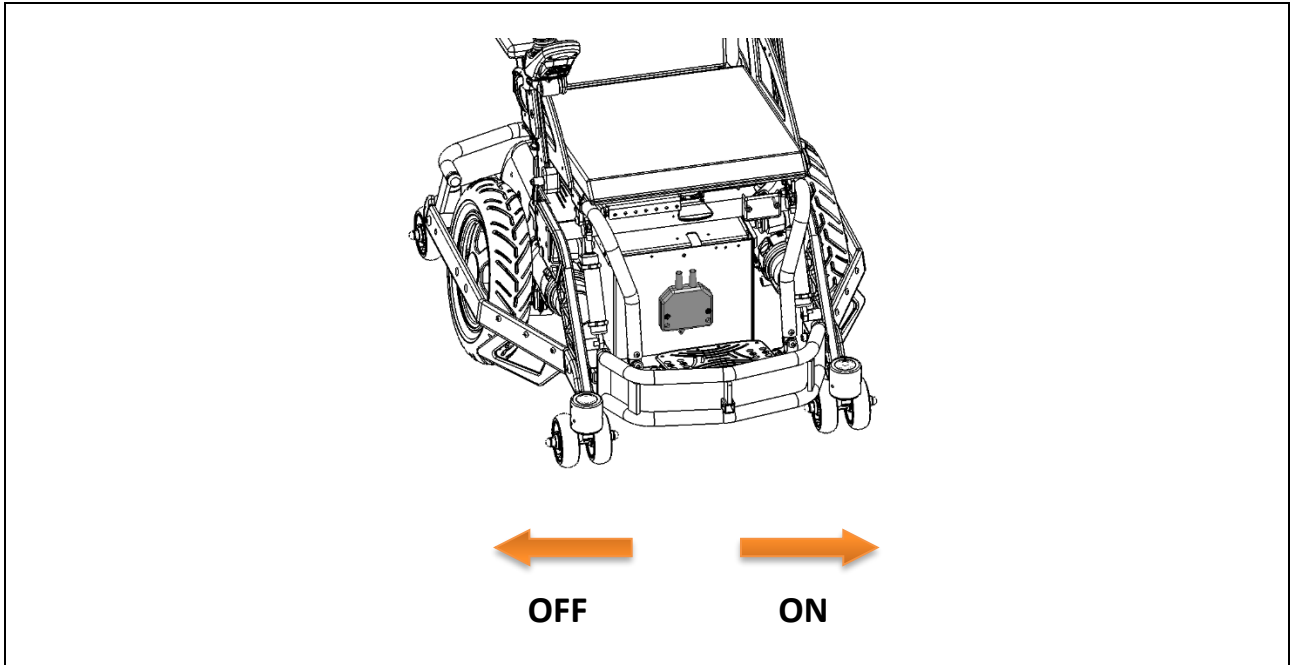
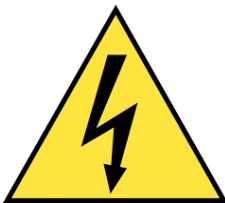

Figure 21

Figure is taken having the wheelchair on the front and shows the position ON and OFF of the switch.

If the power chair suddenly stops, use the switch to connect again batteries to the power module and turn on again the wheelchair. **If the problem still continues, it means that there is some electric fault.**



**If the switch operates, often this means that there is a major electrical fault. The cause of fault should be checked carefully.**



**For more information, please contact the manufacturer.**



## 4.5 Battery charging

In order to recharge batteries, use only the provided charger or one recommended by the manufacturer. The manufacturer is not responsible for any damage to person or objects resulting from the use of non-original product.



### CHARGER SPECIFICATION

24 V -MIN 6 A MAX 10 A - Charge profile for AGM batteries

- Connect the power cord to a power supply 230 V.
- Connect the cable to the joystick or to the chassis as shown in Figure.

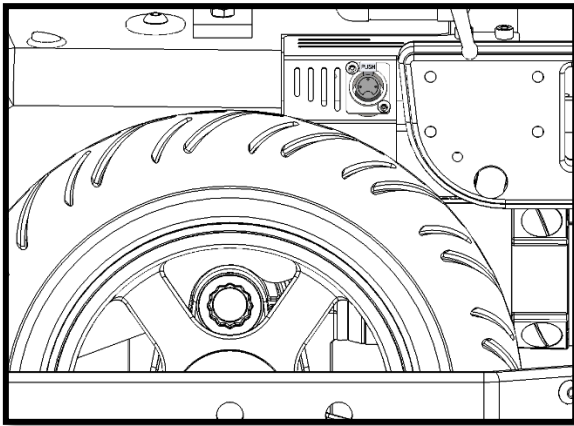

RNET

Figure 22

- When batteries are loaded unplug the power cord and the battery cable from the joystick.



### RUNNING-IN PERIOD

Typically, batteries are able to offer 100% performance after about 15-20 cycles.



### BATTERIES SPECIFICATION

Seat width from 300 mm to 360 mm: 24 V - 35 Ah - about 197x131x180 (h) mm - about 11 kg  
Seat width from 380 mm to 460 mm: 24 V - 50 Ah - about 198x166x171 (h) mm - about 15 kg

### WHEN AND HOW IT IS NECESSARY TO CHARGE BATTERIES?



**It is very important to charge batteries every day, even if they are not completely discharged.** Each battery is subject to a normal self-discharge, so batteries that are not used for long time will discharge by itself.

**It is very important to don't let batteries uncharged for long time.**

**It is very important to complete every cycle of charging**

Charging time is influenced by multiple factors such as remaining battery power, battery state of aging and temperature. However, the approximate charging time is about 12 hours.



Battery charging should be done in well ventilated environments. Never charge in bathroom or wet room.

**When the charger is connected it is not possible to drive the wheelchair. Don't use the wheelchair during the charge.**

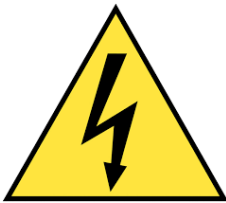

#### SHOCK HAZARD

Check if charger requirements data matches with the network power (voltage, frequency)



#### RELEASE DANGER

Any impact to the batteries could cause a loss of fluids. Please pay special attention.



#### BATTERIES DISPOSAL

To properly recycle the batteries follow instructions provided by your local waste disposal service.

## 4.6 Cooling fan

Under the back cover of the wheelchair there is a fan with the aim of cooling the main Power Module.

It is possible to turn on and off the fan acting on the switch shown in Figure .

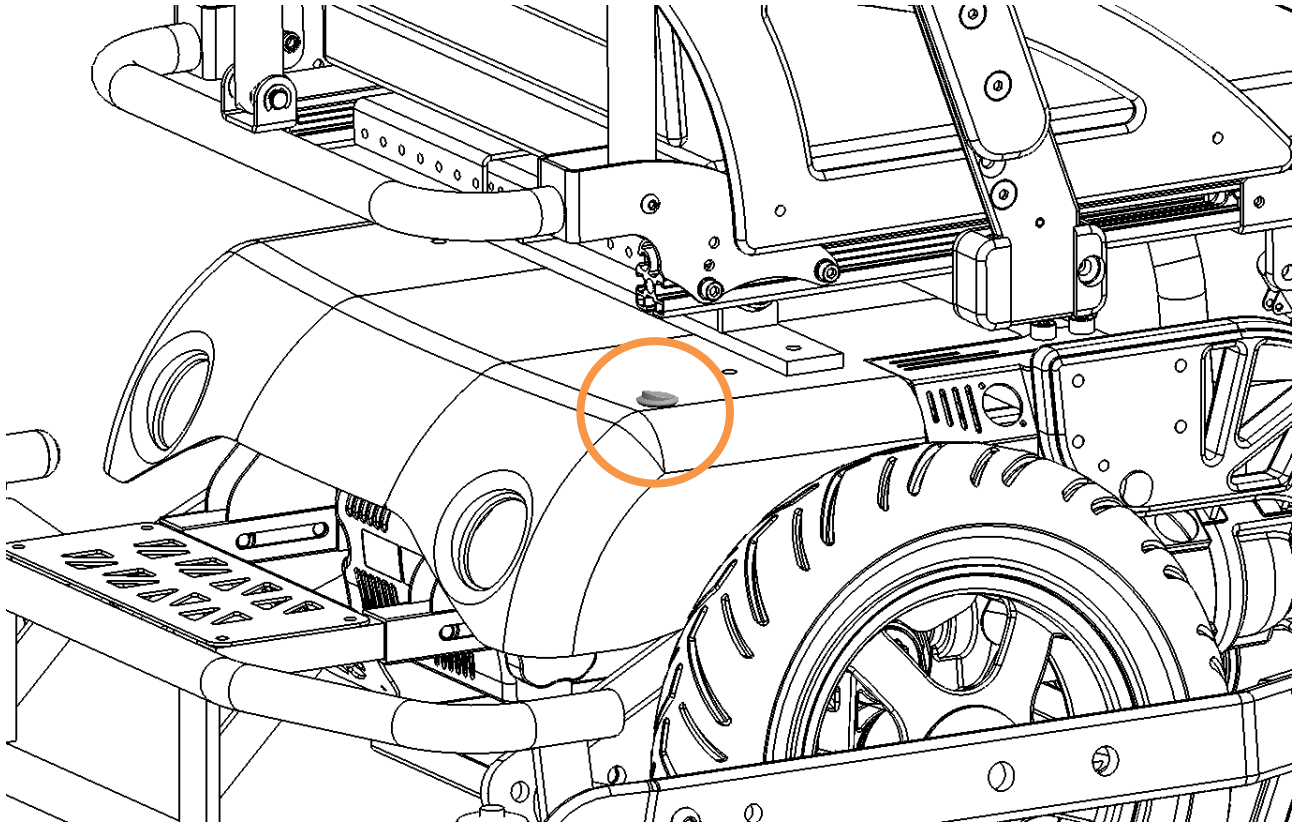

Figure 58

## 4.7 Front protection

It is possible to have different type of front protection.

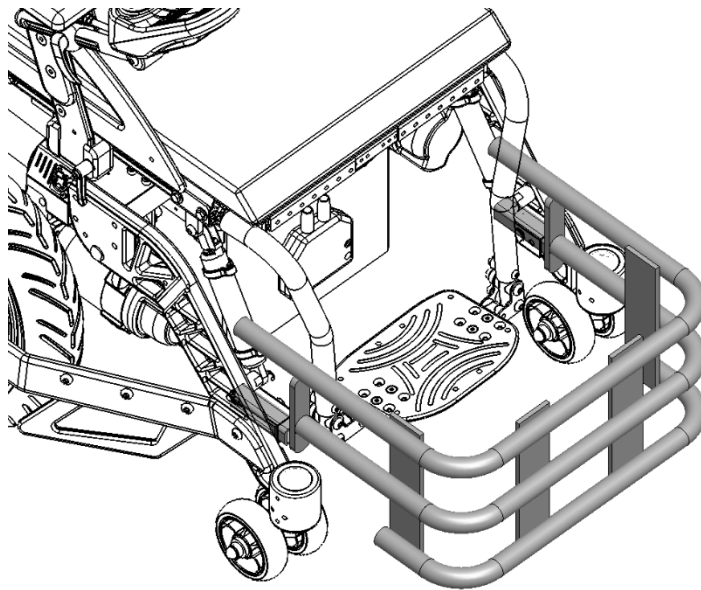

Figure 58 - Football front protection

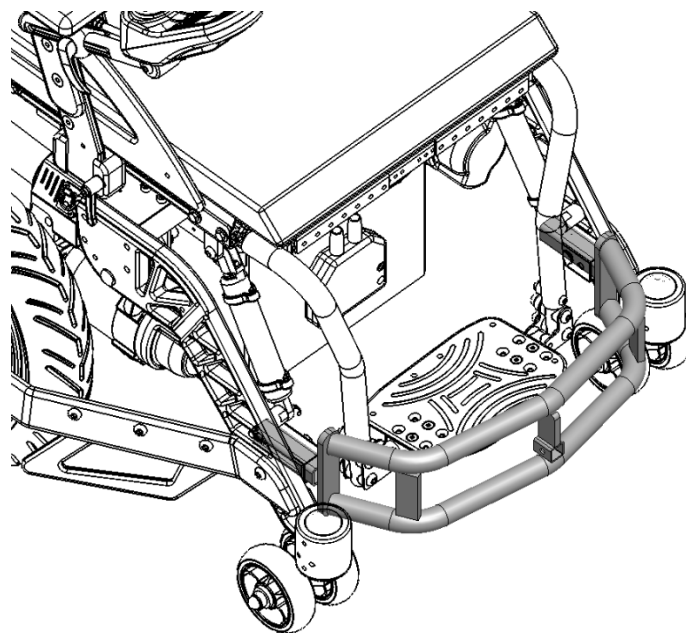

Figure 58 - Hockey front protection 1

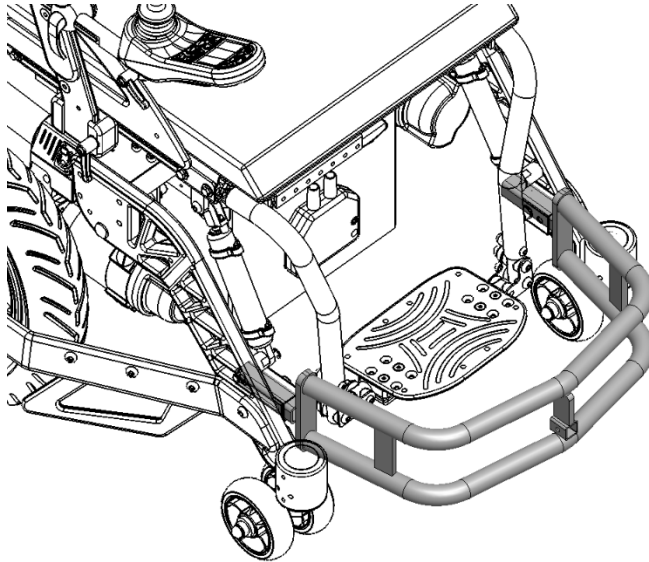

Figure 58 - Hockey front protection 2

## 4.8 Transport and storage

If you are not willing to use the wheelchair for a long period, keep it safe in a clean area and away from heat.

If it is necessary to transport the wheelchair to facilitate operation follow these instructions.

It is possible to store the wheelchair in a place with a temperature between -20 °C and +45 °C.

- Turn off the wheelchair.
- Turn off the main switch. See section 4.4.



### **WARNING**

If you transport the wheelchair with motors disengaged, the wheelchair is free to move. This may result in a hazardous situation.

## 4.8.1 Batteries removal

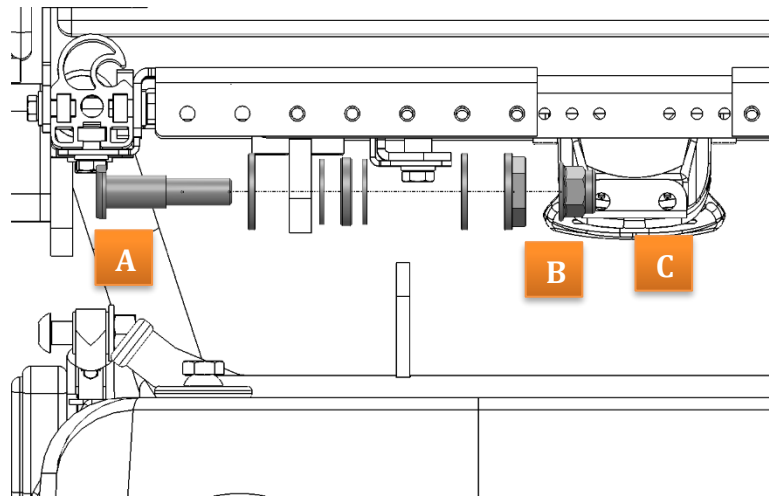

Figure 23

- Use a 17 mm open-end wrench to block the bolt (A) and a 15 mm open-end wrench to unscrew the nut (C).
- Use a 17 mm open-end wrench to block the bolt (A) and a 22 mm open-end wrench to unscrew the nut (B).
- Swipe away the bolt and pay attention to dismantled nuts.
- 

OPEN-END WRENCH

22 mm



OPEN-END WRENCH

17 mm



OPEN-END WRENCH

15 mm

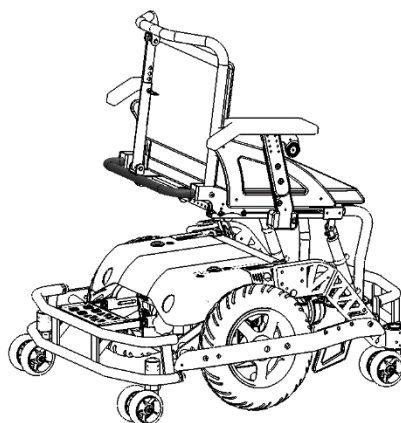

Figure 24

- Use the highlighted bar in figure to pull toward the seat



### WARNING

The weight of the seat of the wheelchair is about 15 kg according to the chosen configuration. Thought it is still fixed on the chassis and you don't have to bear its complete weight, please pay attention while handling. Grab the seat with two hands at the same time on the bar shown in Figure.

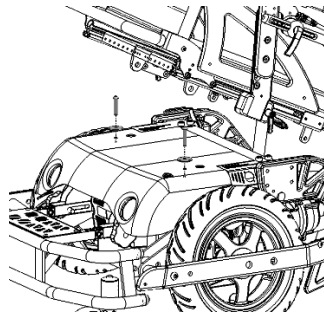

Figure 25

- Unscrew the screws shown in figure.
- Remove the cover. While removing unplug the connector of the switch of the fan.

ALLEN WRENCH



6 mm

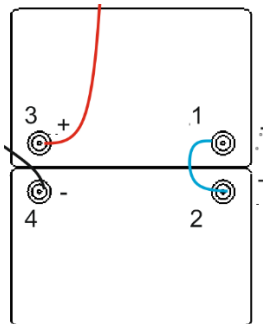

Figure 26

- Unscrew the screws shown in figure following the given order (1-2-3-4).
- Pull away the batteries.

ALLEN WRENCH



5 mm





### **WARNING**

The weights of each battery is about 25 kg. Please pay special attention while handling.

The wheelchair can be transported in the storage compartment of the vehicle even without any package. The unoccupied wheelchair can be also shipped via air. If it is necessary to ship the wheelchair it is very important to protect it with an appropriate package.

It is not possible to provide a universal package, so the user should provide himself for it. The used package must be water and dust resistant and strong enough to protect the wheelchair from any hurts. When inserting the wheelchair into the package protect any protruding parts with some foam or similar.

## 5 MAINTENANCE

Please remind that the wheelchair is intended exclusively for the carriage of seated people. Below there are some precautions for the use of the wheelchair, which it is recommend to follow, in order to ensure a safe use and a long duration.

Regular maintenance helps to keep intact the functionality and safety of the wheelchair. Inadequate or lack of care and maintenance may cause a limitation of the warranty.

- Avoid prolonged contact of the wheelchair with water. It may cause oxidation of the metal parts.
- Avoid long exposure of the wheelchair to direct sunlight.



### WARNING

**Any work on the wheelchair must be performed by an authorized service center.**



### INFORMATION

It is not possible to perform any maintenance on batteries. It is only possible to substitute them.

### 5.1 Maintenance and cleaning

To clean the wheelchair do not use high-pressure water spray devices. For plastic and metal parts use a soft cloth dampened with mild detergent. For the upholstery, linings, seat and back covers use warm water and mild detergent. Do not use stain removers, solvents, acids, etc.

## 5.2 Controls to be performed on the product

Type of operation	
<b>A</b>	Operation intended to be performed by the user.
<b>B</b>	Operation intended to be performed by an assistant.
<b>C</b>	Operation intended to be performed by an authorized service center.

Operation	Frequency	Type of operation
Check if motors are correctly locked. See section 4.2.	Before each use	B - Assistant
Check that no wires are in the way for the movements of the chair	Before each use	B - Assistant
Check the charge of batteries	Daily	A - User
Clean the wheelchair	Weekly	B - Assistant
Check if the pressure is the one indicated on tires and in section <b>Errore. L'origine riferimento non è stata trovata.</b> Traction wheels: 280 kPa; Castors: 250 kPa.	Weekly	B - Assistant
Check if the lever of the main switch works correctly	Weekly	B - Assistant
Check tire usury	Monthly	B - Assistant
Check brake release lever	Monthly	B - Assistant
Check aging of batteries	Monthly	C - Service

## 5.3 Tire puncture

### 5.3.1 User information

#### Traction wheel

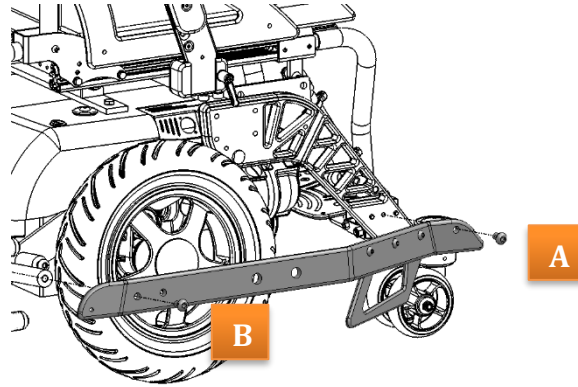

Figure 27

- Unscrew the screw (A) using a 5 mm allen wrench.
- Unscrew the screw (B) using a 6 mm allen wrench.
- Remove the bar.

ALLEN WRENCH



6 mm

ALLEN WRENCH



5 mm

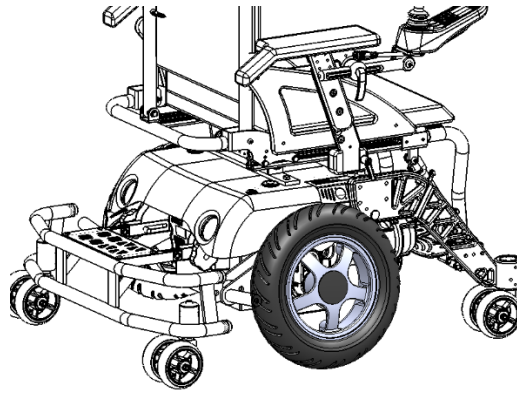

Figure 28

- Rise the wheelchair so that traction wheels are not touching the ground.
- Using a lever remove the plastic cap of the wheel.
- Unscrew the screw of the wheel
- Remove the wheel

ALLEN WRENCH



6 mm



Contact an authorized service center for the repair or the substitution of the damaged wheel. When the authorized service center gives you back the repaired wheel or a new one, mount it following instructions in reverse order.

### 5.3.1 Service information

When the user requires assistance for a punctured wheel, according to the entity of damage, decide if it is better to repair or substitute the wheel.

Code	Description	Type of operation
R065-0020	Traction wheel	A
R065-0021	Tube of traction wheel	B
R045-0022	Tire of traction wheel	B

Table 5

Type of operation	
<b>A</b>	Parts that can be bought at an authorized service center and substitute autonomously
<b>B</b>	Parts that need to be substituted at an authorized service center.

**5.4 Wiring diagram**

**5.4.1 Rnet**

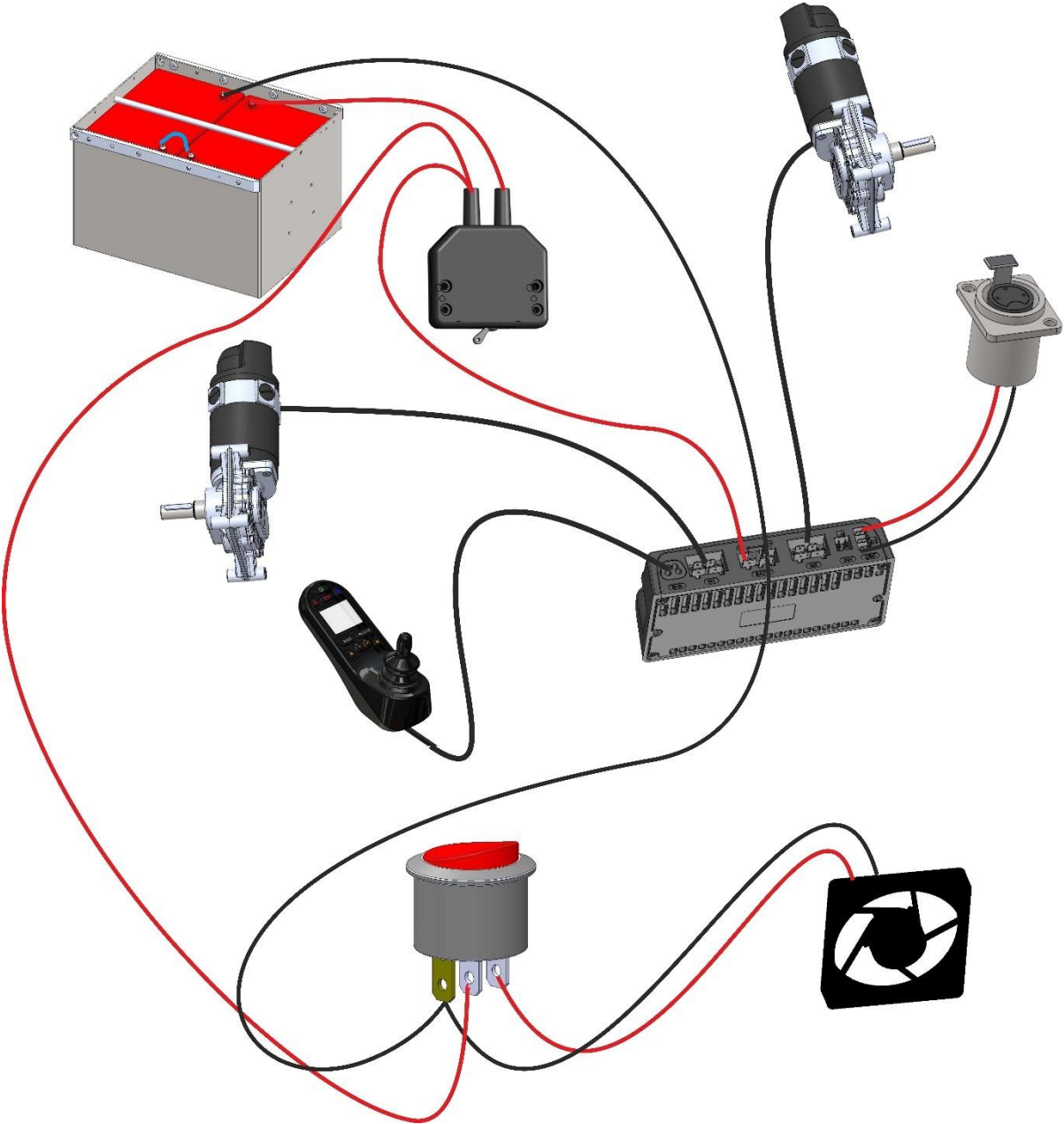
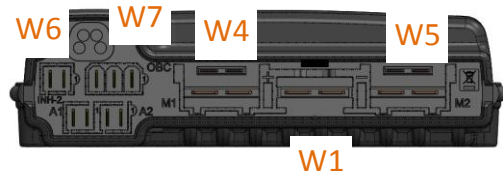
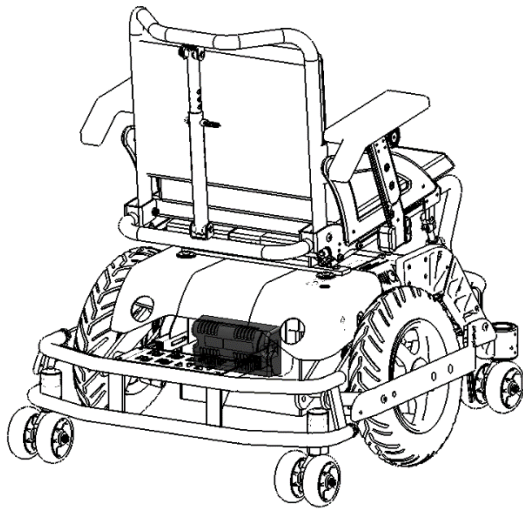

Figure 29

## A - Power module



W1	Battery pack and main switch
W4 (included in motor)	Motor 1 left
W5 (included in motor)	Motor 2 right
W6	BUS
W7	Charger connector



## B - Battery pack and main switch

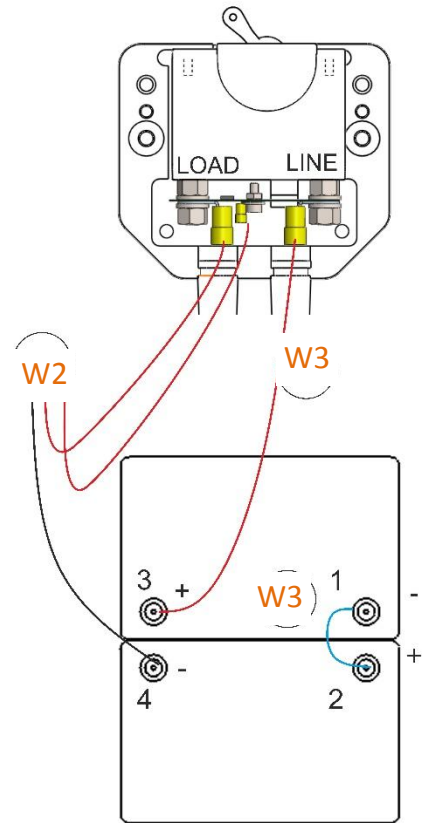
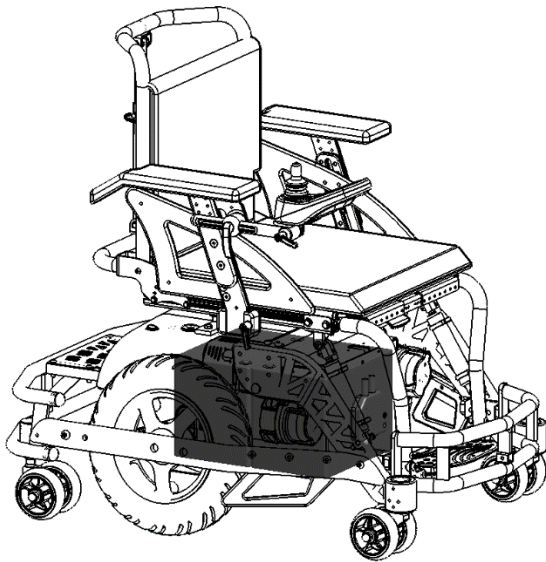

W2

Power module and fan

## C - Fan and switch

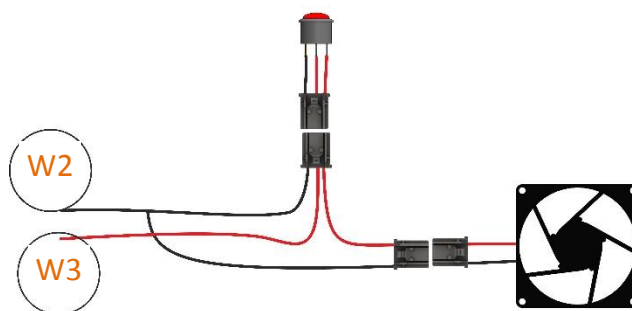
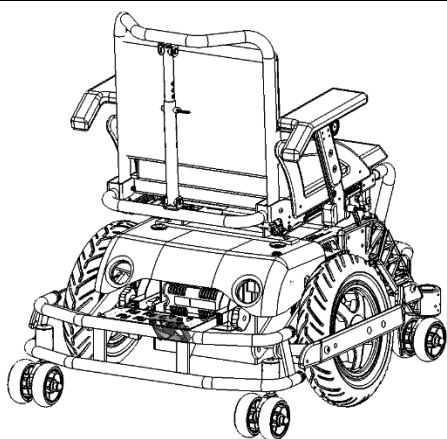

W2

Power module

W3

Main switch

## 5.5 Batteries replacement

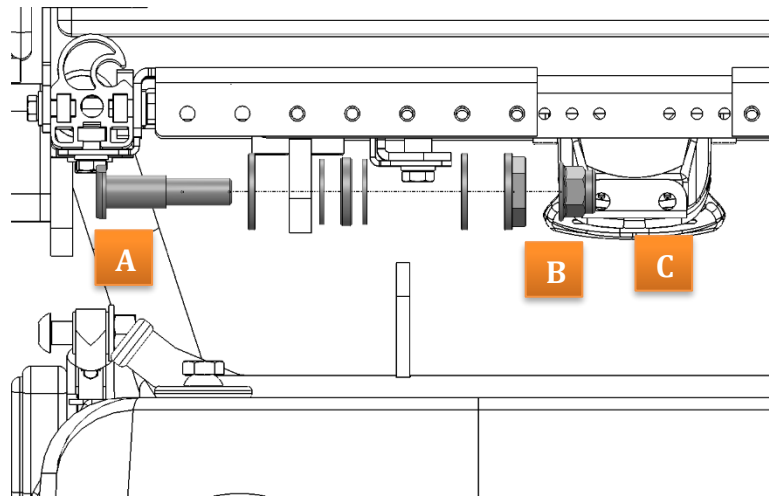

Figure 30

- Use a 17 mm open-end wrench to block the bolt (A) and a 15 mm open-end wrench to unscrew the nut (C).
- Use a 17 mm open-end wrench to block the bolt (A) and a 22 mm open-end wrench to unscrew the nut (B).
- Swipe away the bolt and pay attention to dismounted nuts.
- 

OPEN-END WRENCH

22 mm



OPEN-END WRENCH

17 mm



OPEN-END WRENCH

15 mm

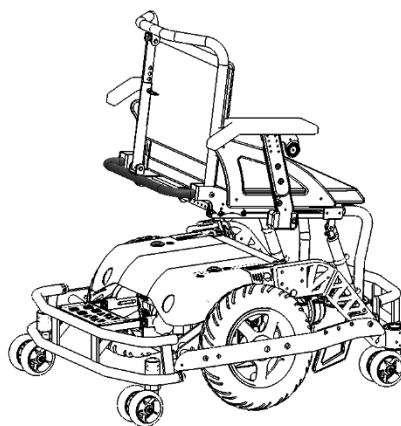

Figure 31

- Use the highlighted bar in figure to pull toward the seat



### WARNING

The weight of the seat of the wheelchair is about 15 kg according to the chosen configuration. Thought it is still fixed on the chassis and you don't have to bear its complete weight, please pay attention while handling. Grab the seat with two hands at the same time on the bar shown in Figure.

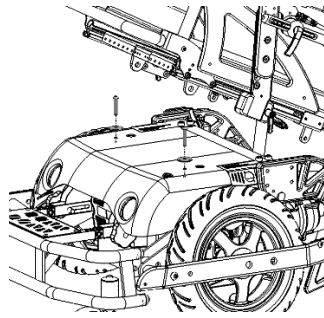

Figure 32

- Unscrew the screws shown in figure.
- Remove the cover. While removing unplug the connector of the switch of the fan.

ALLEN WRENCH



6 mm

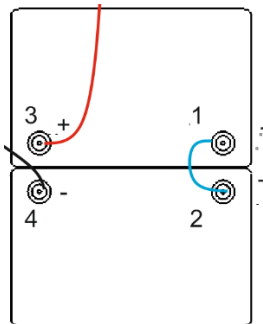

Figure 33

- Unscrew the screws shown in figure following the given order (1-2-3-4).
- Pull away the batteries.
- Mount new batteries following instructions in reverse order. When connecting cables please follow given order (1-2-3-4).

ALLEN WRENCH



5 mm



### **WARNING**

The weights of each battery is about 25 kg. Please pay special attention while handling.



### **BATTERIES SPECIFICATION**

12 V - C20 75 Ah - AGM or GEL type - Dimensions 260x170x205(h)

<b>Code</b>	<b>Description</b>	<b>Type of operation</b>	<b>Notes</b>
<b>R045-0110</b>	Batteries	B	

## 5.6 Reuse

The product is suitable for reuse. Before dispensing it, the product must be cleaned, and subjected to maintenance. The operating instructions are included in this manual and must also be provided when the product is passed on.



### **WARNING**

**This operation must be performed only at an authorized service center.**

## 5.7 Spare parts

Type of operation	
<b>A</b>	Parts that can be bought at an authorized service center and substitute autonomously
<b>B</b>	Parts that need to be substituted at an authorized service center.

Table 6

Code	Description	Type of operation	Notes
R045-0110A	Batteries	B	
R065-0020	Traction wheel	A	
R065-0021	Tube of traction wheel	B	
R045-0022	Tire of traction wheel	B	
R045-0030	Lateral bar $\varnothing$ 320x58 mm	A	
R045-0220	Wheel protection	B	
R045-0040A	Front castor with fork	B	
R045-0040B	Rear castor with fork	B	
R045-0041	Single wheel of castor	A	
R045-0042	Bearings	B	
R045-0050	Cover	A	
R045-0060	Fan with mounting plate	A	
R045-0061	Fan	A	
R045-0062	Switch		
R045-0170	Motors - couple	B	



<b>R045-0180</b>	Main switch	B
<b>R045-0181</b>	PCB fuse for main switch	B
<b>R045-0182</b>	Lever for main switch	A
<b>R045-0190A</b>	Standard joystick support	A
<b>R045-0200A</b>	Joystick Rnet	A
<b>R045-0210A</b>	Power module Rnet	B
<b>R045-0230</b>	Charger	A
<b>R045-0320F</b>	Footplate unique - seat width 360 mm - 380 mm	A
<b>R045-0320G</b>	Footplate unique - seat width 400 mm	A
<b>R045-0320H</b>	Footplate unique - seat width 420 mm - 480 mm	A
<b>R045-0320J</b>	Footplate unique - seat width 500 mm	A
<b>R045-0321</b>	Fixing system for footrest	A
<b>R045-0330</b>	Gas spring	B
<b>R045-0331</b>	Gas spring support	
<b>R045-0332</b>	Lever for tilting	
<b>R045-0372</b>	Telescopic bar for backrest	
<b>R045-0373</b>	Backrest pin	A
<b>R045-0391</b>	Armrest padding	A
<b>R045-0392</b>	Armrest support	A
<b>R045-0393</b>	Armrest fixing system	A
<b>R045-0394</b>	Lever for armrest	A
<b>R045-0395A</b>	Armrest lower support standard	A

<b>R045-0396</b>	Sidepad	A
<b>R045-0400</b>	Rear protection (without castor)	A
<b>R045-0410A</b>	Front protection football	A
<b>R045-0410B</b>	Front protection hockey 1	A
<b>R045-0410C</b>	Front protection 2	A
<b>R045-0410D</b>	Stick	A
<b>R045-0420A</b>	Backrest canvas - seat 360 mm	A
<b>R045-0420A</b>	Backrest canvas - seat 380 mm	A
<b>R045-0420B</b>	Backrest canvas - seat 400 mm	A
<b>R045-0420C</b>	Backrest canvas - seat 420 mm	A
<b>R045-0420D</b>	Backrest canvas - seat 440 mm	A
<b>R045-0420E</b>	Backrest canvas - seat 460 mm	A
<b>R045-0420F</b>	Backrest canvas - seat 480 mm	A
<b>R045-0420G</b>	Backrest canvas - seat 500 mm	A
<b>R045-0430A</b>	Seat cushion - seat 360 mm	A
<b>R045-0430B</b>	Seat cushion - seat 380 mm	A
<b>R045-0430C</b>	Seat cushion - seat 400 mm	A
<b>R045-0430D</b>	Seat cushion - seat 420 mm	A
<b>R045-0430E</b>	Seat cushion - seat 440 mm	A
<b>R045-0430F</b>	Seat cushion - seat 460 mm	A
<b>R045-0430G</b>	Seat cushion - seat 480 mm	A
<b>R045-0430H</b>	Seat cushion - seat 500 mm	A

**Table 7**



### **WARNING**

The use of spare parts or accessories not approved by the manufacturer may make the wheelchair unstable or uncontrollable.

**For each order, always contact an authorized service center.**



### **CONTACT INFORMATION**

For any other part not described in this manual please contact the manufacturer.

## 6 SPECIFICATIONS

Maximum safety slope (uphill, 6° downhill, lateral)	
Expected lifetime [years]	10
Recommended tire pressure [kPa]	Traction wheels: 280 kPa
Standard compliance	ISO 14971: 2007 ISO 7176-14:2008 ISO 7176-21:2009

Intended use	The Xtreme wheelchair is intended for those groups of users with temporary or permanent mobility difficulties confined to a sitting position who need to use the wheelchair for indoor sport activities as for example hockey or football.
--------------	--

**WARNING**



**It is prohibited to use the product or its parts for any purpose other than that indicated. The manufacturer disclaims any responsibility for damages caused by improper use of aids.**

It is possible to use the wheelchair when the temperature is between -10 °C and +40 °C.

It is possible to store the wheelchair in a place with a temperature between -20 °C and +45 °C.

## 6.1 Maximum user weight

Seat width	MAX
36 cm	75 kg
38 cm	100 kg
40 cm	100 kg
42 cm	150 kg
44 cm	150 kg
46 cm	150 kg
48 cm	150 kg
50 cm	150 kg

Table 8

## 6.2 Other provided information

Manufacturer	Neatech.it srl
Address	via A. de Curtis 4/A – 80040 – Cercola (NA) - Italy
Model	S065 – Xtreme

Description	Value
<b>Overall length with legrest</b>	MIN: 980 mm MAX: 1100 mm
<b>Overall width</b>	730 mm
<b>Folded length</b>	N.A.
<b>Folded width</b>	N.A.
<b>Folded height</b>	N.A.
<b>Total mass</b> (the weight may change significantly according to the configuration of the wheelchair)	MAX 105 kg
<b>Dynamic stability</b>	N.A.
<b>Static stability downhill</b>	N.A.
<b>Static stability uphill</b>	N.A.
<b>Static stability sideways</b>	N.A.
<b>Seat plane angle</b>	MIN 0° MAX 15°
<b>Effective seat depth</b>	MIN: 34.0 cm MAX: 46.0 cm

<b>Effective seat width</b>	MIN: 36.0 cm MAX: 50.0 cm
<b>Seat surface height at front edge</b>	50.0 cm
<b>Backrest angle</b>	MIN: 80° MAX: 135°
<b>Backrest height</b>	420 mm
<b>Footrest to seat distance</b>	MIN: 30.0 cm MAX: 36.0 cm
<b>Armrest to seat distance</b>	MIN: 30.5 cm MAX: 35.5 cm

### 6.3 Dimensions

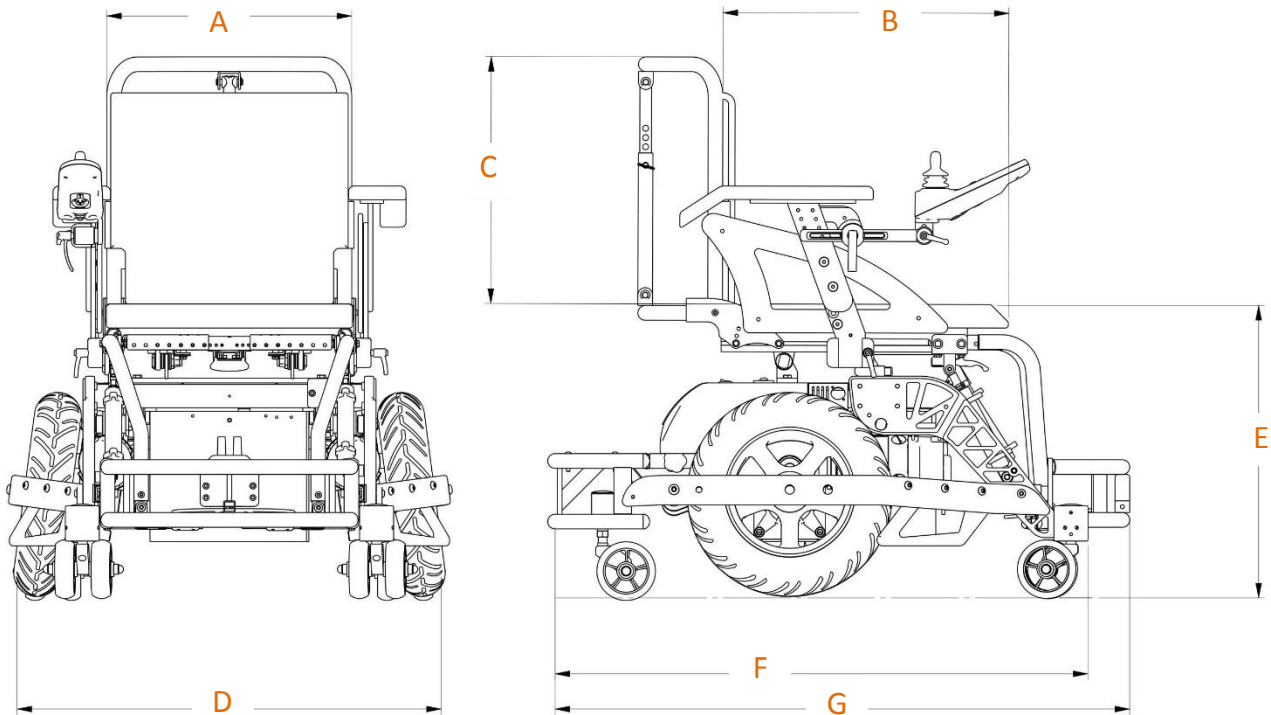

<b>A</b>	<b>360 mm</b>	<b>380 mm</b>	<b>400 mm</b>	<b>420 mm</b>	<b>440 mm</b>	<b>460 mm</b>	<b>480 mm</b>	<b>500 mm</b>
<b>B</b>	MIN 340 mm MAX 460 mm							
<b>C</b>	420 mm							
<b>E</b>	500 mm							
<b>G</b>	Football front protection : 1100 mm Hockey 1 front protection : 980 mm Hockey 2 front protection : 1070 mm							



## 7 WARRANTY TERMS

The product is globally guaranteed for 24 months **with the exception of the batteries that are guaranteed for 6 months** from the delivery to the first user. The warranty covers defects in materials or workmanship. The warranty doesn't cover parts subject to usury or damaged parts by: overload, misuse, alterations and repairs made by unauthorized third parties from the manufacturer. The warranty expires in case of tampering, improper storage, unauthorized or incorrect maintenance.

### 7.1 Serial number

For any report or assistance request, please communicate the serial number mentioned on the label in the position shown in figure.

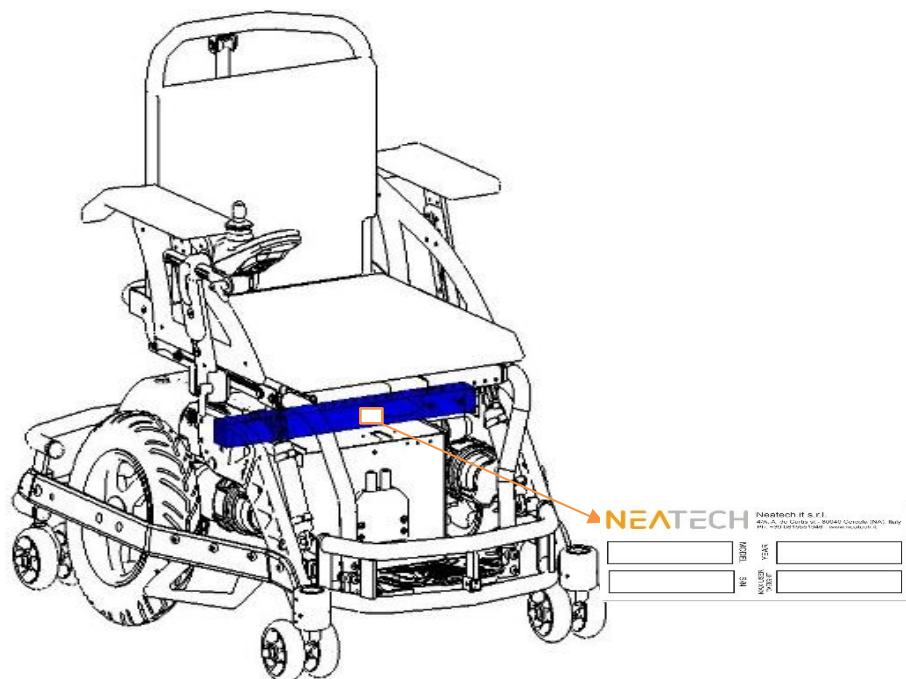

Figure 34







# EVO 1

Neatech.it s.r.l.  
Via A. De Curtis 4/a  
80040 Cercola (Na) Italy  
ph. +39 081 5551946  
fax +39 081 5552507  
e-mail [info@neatech.it](mailto:info@neatech.it)  
[www.neatech.it](http://www.neatech.it)