



Invacare[®] Storm[®] 4

Storm⁴, Storm⁴ X-plore, Storm⁴ True Track

EN Power Wheelchair
User Manual



This manual **MUST** be given to the user of the product.
BEFORE using this product, read this manual and save for future reference.



Yes, you can.[®]

© 2014 Invacare® Corporation

All rights reserved. Republication, duplication or modification in whole or in part is prohibited without prior written permission from Invacare. Trademarks are identified by ™ and ®. All trademarks are owned by or licensed to Invacare Corporation or its subsidiaries unless otherwise noted.

Contents

I General	7
1.1 Introduction	7
1.2 Symbols in this manual	7
1.3 Type classification and intended use	8
1.4 Indications	8
1.5 Usability	8
1.6 Warranty	9
1.7 Service life	9
2 Safety	10
2.1 General safety notes	10
2.2 Safety information with regard to care and maintenance	12
2.3 Safety information on electromagnetic interference	12
2.4 Safety information on driving and freewheel mode	13
2.5 Safety information regarding changes and modifications to the mobility device	14
2.6 Safety information on wheelchairs with a lifter	16
2.7 Safety information on wheelchairs with Recaro seats and AJ Optimist seats	17
2.8 The position of the labels on the product	18
3 Components	21
3.1 Key features	21
3.2 Remotes	21
4 Getting in and out of the mobility device	22
4.1 Removing the standard armrest in order to side transfer	22
4.2 Disconnecting the remote	22
4.3 Information about getting in and out	22
4.4 Using the cane holder	23

5 Driving	24
5.1 Before driving for the first time	24
5.2 Parking and stationary	24
5.3 Taking Obstacles	24
5.3.1 Maximum obstacle height	24
5.3.2 Safety information when ascending obstacles	24
5.3.3 The correct way to overcome obstacles	25
5.4 Driving up and down gradients	25
5.5 Using foldable antitippers	26
5.6 Use on public roads	27
5.7 Pushing the mobility device in freewheel mode	27
5.7.1 Disengaging motors (conventional motors)	27
5.7.2 Disengaging the motors (GB motors)	28
6 Adjusting the mobility device to the user's seating posture	30
6.1 General information on adjusting the wheelchair to the user's seating posture	30
6.2 Adjustment possibility for remote	30
6.2.1 Adjusting the remote for the length of the user's arm (all seat systems)	31
6.2.2 Adjusting the height of the remote (only for swing-away remote holders)	31
6.2.3 Swivelling the remote to the side	31
6.3 Adjustment options for standard armrests	31
6.3.1 Changing the arm support position	31
6.3.2 Setting the height of the armrests	32
6.3.3 Adjusting the width of the armrests	32
6.4 Adjustment options for parallel sliding armrests	33
6.4.1 Setting the height of the parallel sliding armrests	33
6.4.2 Adjusting the angle of the armpad on the parallel sliding armrests	33

6.4.3	Adjusting the width of the parallel sliding armrests	34	6.8.2	Adjusting the height of the headrest or neckrest	44
6.4.4	Adjusting the mobility of the parallel sliding armrests	35	6.8.3	Adjusting the cheek supports	44
6.4.5	Adjusting the arm support positions for the parallel sliding armrests.	35	6.9	Postural belts	44
6.5	Adjustment options for the Modulite seat unit	36	6.9.1	Types of postural belts	45
6.5.1	Adjusting the height of the armrests	36	6.9.2	Adjusting the postural belt correctly	45
6.5.2	Adjusting the width of the armrests	36	6.10	The Lifter	45
6.5.3	Adjusting the position of the armrest in depth.	37	6.11	Adjusting the trunk support (Easy-Adapt seating system)	46
6.5.4	Adjusting the seat width	37	6.11.1	Adjusting the width	46
6.5.5	Adjusting the seat depth	38	6.11.2	Adjusting the height	47
6.6	Adjusting the seat angle	38	6.11.3	Adjusting the depth	47
6.6.1	Electrical	38	6.12	Adjusting and removing the tray	47
6.6.2	Manual.	38	6.12.1	Laterally adjusting the tray	48
6.7	Adjusting the backrest.	39	6.12.2	Adjusting the depth of the tray / removing the tray	48
6.7.1	Electrical	39	6.12.3	Swinging the tray away to the side.	48
6.7.2	Adjusting the backrest (standard seat) — manually with handscrews.	39	6.13	Seat support	48
6.7.3	Adjusting the back seat angle on the Easy-Adapt seating system	40	6.13.1	Adjusting seat width	48
6.7.4	Adjusting the height of the backrest (Modulite seat unit)	40	6.13.2	Adjusting the seat depth	49
6.7.5	Adjusting the width of the backrest (Modulite seat unit)	40	6.13.3	Adjusting the seat depth without replacing the seat support plate.	50
6.7.6	Adjusting the backrest angle (Modulite seat unit)	41	6.13.4	Adjusting the seat depth with replacing the seat support plate	51
6.7.7	Adjusting the adaptable backrest padding	42	6.14	Backrest unit with ergonomic length compensation (Easy-Adapt)	52
6.8	Adjusting the headrest.	43	6.14.1	Adjusting the width	52
6.8.1	Adjusting the position of the headrest or neckrest	43	6.15	Adjusting the suspension and the shock absorbance	53
			6.15.1	Adjusting the suspension (Storm ⁴ X-plore only)	53
			6.15.2	Disabling the suspension and shock absorbance	54
			6.15.3	Adjusting the shock absorbance.	54

6.16	Adjusting or removing the luggage carrier	55	7.5.1	Swivelling the legrest outward and/or removing	68
6.17	Using the KCLICKfix adapter	56	7.5.2	Setting the angle	69
7	Adjusting footrests and legrests	57	7.5.3	Adjusting the length of the legrest	69
7.1	Center-mounted legrests — Electric legrest	57	7.5.4	Adjusting the depth of the calf pad	69
7.1.1	Lowering the electric legrest completely to assist getting out of the wheelchair	57	7.5.5	Adjusting the height of the calf pad	70
7.2	Center-mounted legrests — Adjustable legrest	58	7.5.6	Unlocking and swivelling the calf pad backward when alighting	71
7.2.1	Adjusting the angle	58	7.5.7	Adjusting the angle-adjustable foot plate	71
7.2.2	Adjusting the length of the legrest	58	7.5.8	Adjusting the angle- and depth-adjustable foot plate	71
7.2.3	Adjusting the calf pad to the calf width of the user	59	7.6	Angle-adjustable footboard	72
7.2.4	Adjusting the angle of the foot plate	59	7.7	Adjusting the width of side-mounted legrests	72
7.3	Vari-F footrest	59	8	Electrical system	74
7.3.1	Swivelling the footrest/legrest outward and/or removing	59	8.1	Electronics protection system	74
7.3.2	Setting the angle	60	8.2	Batteries	74
7.3.3	Setting the end stop of the footrest	61	8.2.1	General information on charging	74
7.3.4	Adjusting the length of the footrest	62	8.2.2	General instructions on charging	74
7.4	Vari-A legrests	62	8.2.3	How to charge the batteries	75
7.4.1	Swivelling the footrest/legrest outward and/or removing	62	8.2.4	How to disconnect the batteries after charging	76
7.4.2	Setting the angle	63	8.2.5	Storage and Maintenance	76
7.4.3	Setting the end stop of the legrest	64	8.2.6	Instructions on using the batteries	76
7.4.4	Adjusting the length of the legrest	66	8.2.7	Transporting batteries	77
7.4.5	Adjusting the depth of the calf pad	66	8.2.8	General instructions on handling the batteries	77
7.4.6	Adjusting the height of the calf pad	66	8.2.9	How to handle damaged batteries correctly	77
7.4.7	Unlocking and swivelling the calf pad backward when alighting	67	9	Maintenance	78
7.4.8	Adjusting the angle-adjustable foot plate	68	9.1	Maintenance introduction	78
7.4.9	Adjusting the angle- and depth-adjustable foot plate	68	9.2	Cleaning the mobility device	78
7.5	ADE legrests	68	9.3	Inspection checks	78
			9.3.1	Before each use of the mobility device	78
			9.3.2	Weekly	79

9.3.3	Monthly	79
9.3.4	Inspections performed	80
9.4	Repair Instructions	82
9.4.1	Repairing tire punctures (wheel rim type 3.00-8")	82
9.4.2	Repairing punctures (drive wheel with GB motor and pneumatic tires)	83
9.4.3	Repairing a flat front tire (pneumatic tire 3.00-6")	84
10	Transport	86
10.1	Transport — General information	86
10.2	Transferring the mobility device to a vehicle	86
10.3	Use of the mobility device as a seat in a vehicle	87
10.3.1	How the mobility device is anchored in a vehicle for use as a vehicle seat	88
10.3.2	How the user is secured within the wheelchair	89
10.4	Transporting the mobility device without occupant	91
10.4.1	Opening the rear cover	91
10.4.2	Making the batteries accessible	91
10.4.3	Removing/Installing the batteries	92
11	After Use	94
11.1	Refurbishment	94
11.2	Disposal	94
12	Technical data	95
12.1	Technical specifications	95

I General

I.1 Introduction

Dear user,

First we would like to thank you for purchasing our product! We hope that you will have a great deal of pleasure with your new mobility device.

This user manual contains important information and notes about:

- **Safety**
- **Operation**
- **Care and maintenance**

Please take care to read the user manual thoroughly before starting out on your first journey.

If you find that the font size in the print version of the user manual is difficult to read, you can download it as a pdf from the Invacare website. This can then be scaled on screen to a font size that is more comfortable for you.

This mobility device has been constructed for a large circle of users with different requirements.

The decision whether the model is suitable for the user may only be taken by medical specialists with appropriate expertise.

Invacare or their statutory representatives can accept no liability in cases in which the mobility device has not been adapted to suit the users' handicaps.

Some maintenance and settings can be performed by the user or his/hers attendants. Certain adjustments do however require technical training and may only be carried out by your Invacare specialist dealer. Damages and errors caused by nonobservance of 1529686-P

the user manual or as a result of incorrect maintenance are excluded from all guarantees.

This manual contains copyrighted information. This manual may not be reproduced or reprinted either partly or completely without previous written consent from Invacare or its statutory representatives. We reserve the right to make any necessary alterations on the grounds of technical improvements.

I.2 Symbols in this manual

In this user manual warnings are indicated by symbols. The warning symbols are accompanied by a heading that indicates the severity of the danger.



WARNING

Indicates a hazardous situation that could result in serious injury or death if it is not avoided.



CAUTION

Indicates a hazardous situation that could result in minor or slight injury if it is not avoided.



IMPORTANT

Indicates a hazardous situation that could result in damage to property if it is not avoided.



Gives useful tips, recommendations and information for efficient, trouble-free use.



This product complies with Directive 93/42/EEC concerning medical devices. The launch date of this product is stated in the CE declaration of conformity.

Requirements:



This symbol identifies a list of various tools, components and items which you will need in order to carry out certain work. Please do not attempt to carry out the work if you do not have the listed tools available.

1.3 Type classification and intended use

This vehicle was designed for persons whose ability to walk is impaired, but who are still in terms of their eyesight and physically and mentally able to operate an electric vehicle. It has been classified according to EN 12184 as a **class B mobility product** (for indoor and outdoor areas). It is therefore compact and agile enough for indoor areas, but also able to overcome many obstacles in outdoor areas.

You can find precise information about speed, turning radius, driving range, maximum safe slope, maximum obstacle height and permissible operating conditions in chapter 12 Technical data, page 95.

Also pay attention to all safety information in chapter 2 Safety, page 10.

The vehicle was successfully tested according to German and international standards as to its safety. It satisfies the requirements according to RoHS 2011/65/EU, REACH 1907/2006/EC and DIN EN 12184 including EN 1021-1/-2. It was also tested successfully according to EN60529 IPX4 as to its resistance to spray water, and is therefore well suited for weather conditions such as typical European

weather conditions. When equipped with an appropriate lighting system, the vehicle is suitable for use on public roads.

1.4 Indications

The use of this mobility product is recommended for the following indications:

The inability or a greatly restricted ability to walk within the scope of the basic requirement to be able to move within one's own four walls. The need to leave the dwelling place in order to get some fresh air during a short walk or to reach those places generally to be found at close distance to the dwelling and where everyday business is carried out.

Provision of power wheelchairs for interior and exterior areas is advisable if the use of hand-operated wheelchairs is no longer possible on account of the disability, yet proper operation of an electromotive drive unit is still practicable.

1.5 Usability

Only use a mobility device when it is in perfect working order. Otherwise, you might put yourself and others at risk.

The following list does not claim to be exhaustive. It is only intended to show some of the situations that could affect the usability of your mobility device.

In certain situations, you should immediately stop using your mobility device. Other situations allow you to use the mobility device to get to your dealer.

- You should immediately stop using your mobility device if its usability is restricted due to:
 - brake failure

- You should immediately contact an authorised Invacare dealer if the usability of your mobility device is restricted due to:
 - the lighting system (if fitted) failing or being defective
 - reflectors falling off
 - worn thread or insufficient tire pressure
 - damage to the armrests (e.g. torn armrest padding)
 - damage to the legrest hangers (e.g. missing or torn heel straps)
 - damage to the postural belt
 - damage to the joystick (joystick cannot be moved into the neutral position)
 - cables that are damaged, kinked, pinched or have come loose from the holder
 - the mobility device drifting when braking
 - the mobility device pulling to one side when moving
 - unusual sounds developing or occurring
- Or if you have the feeling that something is wrong with your mobility device.

that we estimate a service life for this product does not constitute an additional warranty.

1.6 Warranty

The terms and conditions of the warranty are part of the general terms and conditions particular to the individual countries in which this product is sold.

1.7 Service life

We estimate a service life of five years for this product, provided it is used in strict accordance with the intended use as set out in this document and all maintenance and service requirements are met. The estimated service life can be exceeded if the product is carefully used and properly maintained, and provided technical and scientific advances do not result in technical limitations. The service life can also be considerably reduced by extreme or incorrect usage. The fact

2 Safety

2.1 General safety notes



WARNING!

Risk of injury if mobility device is used in any other way than the purpose described in this manual

- Only ever use the mobility device in accordance with the instructions in this user manual (refer to 1.3 Type classification and intended use, page 8).
- Pay strict attention to the safety information.

Risk of injury if the mobility device is driven when ability to operate a vehicle is impaired by medication or alcohol

- Never drive the mobility device under the influence of medication or alcohol. If necessary, the mobility device must be operated by an attendant who is physically and mentally able.



WARNING!

Risk of damage or injury if mobility device is accidentally set into motion

- Switch the mobility device off before you get in, get out or handle unwieldy objects.
- When the drive is disengaged, the brake inside the drive is deactivated. For this reason, pushing the mobility device by an attendant is only recommended on flat surfaces, never on gradients. Never leave your mobility device on a gradient with its motors disengaged. Always re-engage the motors immediately after pushing the mobility device (refer to Pushing the mobility device in freewheel mode).

Risk of injury if the mobility device is switched off while driving, for example by pressing the On/Off Button or disconnecting a cable, due to it coming to an abrupt, sharp stop

- If you have to brake in an emergency, simply release the joystick which will bring you to a halt (refer to the remote user manual for more information).



WARNING!

Risk of injury when transferring mobility device to a vehicle for transport with the occupant seated in it

- It is always better to transfer the mobility device to a vehicle without the occupant seated in it.
- If the mobility device needs to be loaded up a ramp together with its driver, ensure that the ramp does not exceed the maximum safe slope (refer to I2 Technical data, page 95).
- If the mobility device does need to be loaded using a ramp which exceeds the maximum safe slope (refer to I2 Technical data, page 95), then you must use a winch. An attendant can safely monitor and assist the loading process.
- As an alternative you can use a platform lift. Ensure that the total weight of the mobility device including the user does not exceed the maximum permissible weight for the platform lift or winch if you are using.

Risk of falling out of the mobility device

- Do not slide forward on the seat, do not lean forward between your knees, do not lean backwards out over the top of the backrest, for example to reach an object.
- If a posture belt is installed, it should be correctly adjusted and used each time you use the mobility device.
- When transferring to a different seat, position the mobility device as close as possible to the new seat.



CAUTION!

Risk of injury if maximum permissible load is exceeded

- Do not exceed the maximum permissible load (refer to I2 Technical data, page 95).
- The mobility device is only designed for use by a single occupant whose maximum weight does not exceed the maximum permissible load of the device. Never use the mobility device to transport more than one person.

Risk of injury due to wrong lifting or dropping of heavy components

- When maintaining, servicing or lifting any part of your mobility device, take into account the weight of the individual components especially the batteries. Be sure at all times to adopt the correct lifting posture and ask for assistance if necessary.

Risk of injury by moving parts

- Make sure that no injury is incurred by moving parts of the mobility device, like wheels or one of the lifter modules (if fitted), especially when children are around.

Risk of injury from hot surfaces

- Do not leave the mobility device in direct sunlight for prolonged periods. Metal parts and surfaces such as the seat and armrests can become very hot.

**CAUTION!****Risk of fire or breaking down due to electric devices being connected**

- Do not connect any electric devices to your mobility device that are not expressly certified by Invacare for this purpose. Have all electrical installations done by your authorised Invacare dealer.

2.2 Safety information with regard to care and maintenance**CAUTION!****Risk of accident and loss of guarantee if maintenance is insufficient**

- For reasons of safety and in order to avoid accidents which result from unnoticed wear, it is important that this electric mobility product undergoes an inspection once every year under normal operating conditions (see inspection plan contained in service instructions).
- Under difficult operating conditions such as daily travel on steep slopes, or in the case of use in medical care cases with frequently changing wheelchair users, it would be expedient to carry out intermediate checks on the brakes, accessories and running gear.
- If the mobility product is to be operated on public roads, the vehicle driver is responsible for ensuring that it is in an operationally reliable condition. Inadequate or neglected care and maintenance of the mobility product will result in a limitation of the manufacturer's liability.

2.3 Safety information on electromagnetic interference

This electric vehicle was successfully tested in accordance with International standards as to its compliance with Electromagnetic Interference (EMI) regulations. However, electromagnetic fields, such as those generated by radio and television transmitters, and cellular phones can influence the functions of electric vehicles. Also, the electronics used in our vehicles can generate a low level of electromagnetic interference, which however will remain within the tolerance permitted by law. For these reasons we ask you to please observe the following precautions:

**WARNING!****Risk of malfunction due to electromagnetic interference**

- Do not switch on or operate portable transceivers or communication devices (such as radio transceivers or cellular phones) when the vehicle is switched on.
- Avoid getting near strong radio and television transmitters.
- In case the vehicle should be set in motion unintentionally or the brakes are released, switch it off immediately.
- Adding electrical accessories and other components or modifying the vehicle in any way can make it susceptible to electromagnetic interference. Keep in mind that there is no sure way to determine the effect such modifications will have on the overall immunity of the electronic system.
- Report all occurrences of unintentional movement of the vehicle, or release of the electric brakes to the manufacturer.

2.4 Safety information on driving and freewheel mode



WARNING!

Risk of injury if the mobility device tips over

- Inclines and declines can only be travelled up to the maximum safe slope (refer to 12 Technical data, page 95).
- Always return the backrest of your seat or the seat tilt to an upright position before ascending slopes. We recommend that you position the seat backrest and the seat tilt (if fitted) slightly to the rear before descending slopes.
- Only ever drive downhill at a maximum of 2/3 of the top speed. Avoid abrupt braking or accelerating on gradients.
- If at all possible, avoid driving on slippery surfaces (such as snow, gravel, ice etc.) where there is a risk of you losing control over the vehicle, especially on a gradient. If driving on such a surface is inevitable, then always drive slowly and with the utmost caution.
- Never attempt to overcome an obstacle when on an uphill or downhill gradient.
- Never attempt to drive up or down a flight of steps with your mobility device.
- When overcoming obstacles, always observe the maximum obstacle height (refer to 12 Technical data, page 95 and information about overcoming obstacles in 5.3 Taking Obstacles, page 24).
- Avoid shifting your center of gravity as well as abrupt joystick movements and changes of direction when the mobility device is in motion.



WARNING!

Risk of injury if the mobility device tips over (continued)

- Never use the mobility device to transport more than one person.
- Do not exceed the overall maximum permissible load or the maximum load per axle (refer to 12 Technical data, page 95).
- Note that the mobility device will brake or accelerate if you change the driving mode whilst the mobility device is in motion.



WARNING!

Risk of breaking down in adverse weather conditions, i.e. extreme cold, in an isolated area

- If you are a user with severely limited mobility, we advise that in the case of adverse weather conditions DO NOT attempt a journey without an accompanying attendant.



WARNING!

Risk of injury if your foot slides off the footrest and gets caught underneath the mobility device when it is in motion

- Make sure each time before you drive the mobility device that your feet are squarely and securely in place on the footplates, and that both legrests are properly locked into place.



WARNING!

Risk of injury if you collide with an obstacle when driving through narrow passages such as doorways and entrances

- Drive through narrow passages in the lowest driving mode and with due caution.



WARNING!

Risk of injury

If your mobility device has been fitted with elevating legrests, there is a risk of personal injury and damage to the mobility device if you drive the mobility device with the legrests raised.

- To avoid unwanted displacement of the mobility device center of gravity to the front (especially when travelling downhill) and in order to avoid damage to the mobility device, elevating legrests must always be lowered during normal travelling.



WARNING!

Risk of tipping

Antitippers (stabilizers) are only effective on firm ground. They sink in on soft ground such as grass, snow or mud if the mobility device rests itself on them. They lose their effect and the mobility device can tip over.

- Only drive with extreme care on soft ground, especially during uphill and downhill journeys. In the process pay increased attention to the tip stability of the mobility device.

2.5 Safety information regarding changes and modifications to the mobility device



CE marking of the mobility device

- The conformity assessment/CE marking was carried out in accordance with Directive 93/42 EEC and only applies to the complete product.
- The CE marking is invalidated if components or accessories are replaced or added that have not been approved for this product by Invacare.
- In this case, the company that adds or replaces the components or accessories is responsible for the conformity assessment/ CE marking or for registering the mobility device as a special design and for the relevant documentation.



CAUTION!

Risk of injuries and damage to the mobility device, in case the suspension is adjusted without the immobilization mechanism of the front antitippers being re-adjusted

- When the hardness of the suspension is adjusted, the immobilization mechanism of the front antitippers must without fail be checked and, if necessary, also re-adjusted.



CAUTION!

Risk of injuries and damage to mobility aid due to unapproved components and accessory parts

Seating systems, additions and accessory parts which have not been approved by Invacare for use with this mobility aid can affect the tipping stability and increase tipping hazards.

- Only ever use seating systems, additions and accessory parts which have been approved by Invacare for this mobility aid.

Seating systems which are not approved by Invacare for use with this mobility device do not, under certain circumstances, comply with the valid standards and could increase the flammability and the risk of skin irritation.

- Only use seating systems that have been approved by Invacare for this mobility device.

Electrical and electronic components which have not been approved by Invacare for use with this mobility aid can cause fire hazards and lead to electromagnetic damage.

- Only ever use electrical and electronic components which have been approved by Invacare for this mobility aid.

Batteries which have not been approved by Invacare for use with this mobility aid can cause chemical burns.

- Only ever use batteries which have been approved by Invacare for this mobility aid.



CAUTION!

Risk of injuries, and damage to the mobility device, if unapproved backrests are used

A retrofitted backrest which is not approved by Invacare for use with this mobility device may overload the backrest tube and thus increase the risk of injuries and of damage to the mobility device.

- Please contact your Invacare specialist dealer who will perform risk analyses, calculations, stability checks etc. to ensure that the backrest can be used safely.



Important information about maintenance work tools

- Some maintenance work which is described in this manual and can be carried out by the user without problems require the correct tools for proper work. If you do not have the correct tool available we do not recommend that you try to carry out the relevant work. In this case, we urgently recommend that you contact an authorised specialist workshop.

2.6 Safety information on wheelchairs with a lifter



WARNING!

Risk of injury by moving parts

- Never let objects get caught in the space underneath a raised lifter.
- Make sure that neither you nor anyone else is injured by placing hands, feet or other body extremities under the raised seat.
- Should you not be able to view under the seat, for example, due to limited manoeuvrability, turn the wheelchair once on its own axle before you lower the seat. This will allow you to make sure that nobody is located in the danger zone.



CAUTION!

Risk of injury if the wheelchair tips over

- Never exceed the maximum permissible load (see chapter 12 Technical data, page 95).
- Avoid dangerous driving situations when the lifter is in a raised position, such as trying to overcome obstacles like kerbs or driving up or down steep gradients.
- Never lean out of the seat when the lifter is raised.
- Inspect the lifter module at least once a month to make sure the automatic speed reduction function, which reduces the speed of the wheelchair when the lifter is raised, is working properly (see chapter 6.10 The Lifter, page 45). Notify your authorised dealership immediately if it is not working properly.



CAUTION!

Risk of malfunction of the lifter module

- Inspect the lifter module at regular intervals to make sure there are no foreign objects or visible damage, and to make sure the electric plugs are firmly inserted into their sockets.



CAUTION!

Damage to wheelchair caused by one-sided loading on lifter pillar

- One-sided loading occurs if the seat is raised and/or tilted. Always return your seat backrest to the upright position and the seat tilting to the horizontal position before ascending slopes. Never subject the lifter pillar to continuous single-sided loading. The raising and tilting function of the seat only provides additional rest positions.



Important information regarding speed reduction with raised lifter

- If the lifter has been raised above a certain point, the drive electronics considerably reduces the speed of the wheelchair. If speed reduction has been activated, drive mode can only be used to carry out minor movements of the wheelchair and not for regular driving. To drive normally, please lower the lifter until the speed reduction has been deactivated again.

2.7 Safety information on wheelchairs with Recaro seats and AJ Optimist seats



CAUTION!

Risk of injury if the wheelchair tips over

The center of gravity of a Recaro seat or AJ Optimist seat is higher than that of other seats. These seats are also heavier than other seating systems. The backrest can be leaned back 90° and 60° respectively. For these reasons there is an increased risk of tipping over.

- Never lean the backrest backward more than 30° degrees, and never exceed 15° when driving the wheelchair.

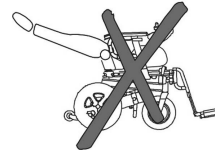

More than 30°
NEVER!!



15°-30°
Standstill!

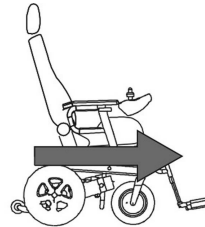



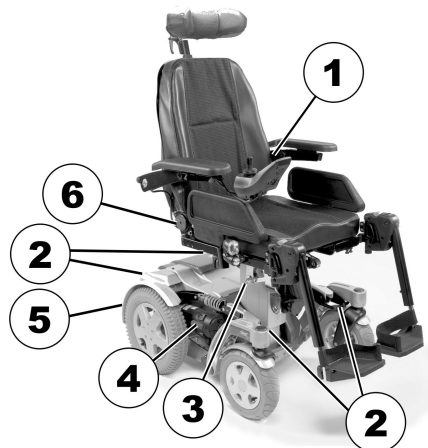

0°-15°
Driving



2.8 The position of the labels on the product









1		<p>If the mobility device is fitted with a tray, it is imperative that it is removed and safely stowed when transporting the mobility device in a vehicle.</p>
2	<p>Identification of the lashing eyes at the front and back:</p>	<p>This symbol indicates the position of an anchor point when using a lashing system during transport.</p>

	<p>If the symbol appears on a bright yellow sticker, the anchoring point is suitable for fixation of the mobility device in a vehicle for use as a vehicle seat.</p>
	<p>Warning that the mobility device may not be used as a vehicle seat</p> <ul style="list-style-type: none"> • This mobility device does not satisfy the requirements of ISO 7176-19:2001 and may not under any circumstances be used as a vehicle seat or to transport the user in a vehicle. • Using a mobility device that does not fulfill these criteria as a vehicle seat can lead to the most severe injuries and even death in the event of a traffic accident.

	<p>This mobility device may be used as a vehicle seat, but only if it is equipped with a headrest that has been approved by Invacare for this purpose.</p> <ul style="list-style-type: none"> • Always make sure that the mobility device is equipped with a headrest approved by Invacare before using it as a vehicle seat.
<p>3 Warning regarding the use of the lifter:</p>	 <p>Do not lean out when the lifter is raised!</p>
	<p>Do not drive up or down slopes when the lifter is raised!</p>
	<p>Do not allow any body parts to get under a raised seat!</p>
	<p>Never drive with two people!</p>

	<p>Never drive over uneven surfaces when the lifter is raised!</p>
<p>4</p>	<p>Identification of the position of the coupling lever for driving and push operation (only the right side is visible in the picture):</p>
	<p>This symbol indicates the “Drive” position of the coupling lever. In this position the motor is engaged and the motor brakes are operational. You can drive the mobility device.</p> <ul style="list-style-type: none"> • Please note that for driving purposes both motors must always be engaged.

	<p>This symbol indicates the “Push” position of the coupling lever. In this position the motor is disengaged and the motor brakes are not operational. The mobility device can be pushed by an attendant and the wheels turn freely.</p> <ul style="list-style-type: none"> • Please note that the control panel must be switched off. • Please also note the information provided in section 5.7 Pushing the mobility device in freewheel mode, page 27.
<p>5</p> 	<p>Identification label sticker on the chassis at the rear right containing the following symbols:</p>
	<p>Date of manufacture</p>
	<p>This product complies with Directive 93/42/EEC concerning medical devices. The launch date of this product is stated in the CE declaration of conformity.</p>

 	<p>This product has been supplied from an environmentally aware manufacturer. This product may contain substances that could be harmful to the environment if disposed of in places (landfills) that are not appropriate according to legislation.</p> <ul style="list-style-type: none"> • The 'crossed out wheeled bin' symbol is placed on this product to encourage you to recycle wherever possible. • Please be environmentally responsible and recycle this product through your recycling facility at its end of life.
<p>6</p> 	<p>Indication of the maximum width to which the armrest can be set</p>

3 Components

3.1 Key features



- 1 Headrest
- 2 Backrest
- 3 Armrest
- 4 Battery case (rear)
- 5 Drive wheel
- 6 Drive motor (with engaging lever)
- 7 Remote
- 8 Legrests
- 9 Caster wheel

10 Suspension, rear (both not visible in illustration, adjustable for Storm4 X-plore only)

11 Suspension, center (Storm4 X-plore only)

3.2 Remotes

Your mobility device may be fitted with one of several different remotes. For information on the different functions and how to operate a particular remote, refer to its corresponding user manual (enclosed).

4 Getting in and out of the mobility device



– The armrest must be removed in order to get into or out of the mobility device from the side.

4.1 Removing the standard armrest in order to side transfer

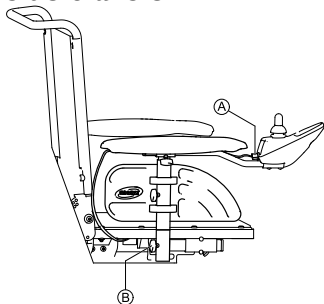

1. Remove the remote cable (A) from the remote. Refer to 4.2 Disconnecting the remote, page 22.
2. Loosen wing nut (B).
3. Remove the armrest from the receptacle.

4.2 Disconnecting the remote

1. Switch off the remote.
- 2.

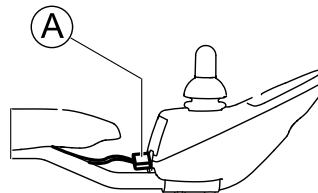

Pull the plug (A) of the remote cable to disconnect the remote.

4.3 Information about getting in and out



Getting into the mobility device:

1. Position your mobility device as close as possible to your seat. This might have to be done by an attendant.
2. Switch your mobility device off.
3. Apply the manual wheel lock of your mobility device (if existing).
4. Depending on the armrest type of your mobility device, detach the armrest or swivel it up.
5. Now slide into the mobility device.

Getting out of the mobility device:

1. Drive your mobility device as close as possible to your seat.
2. Switch your mobility device off.
3. Apply the manual wheel lock of your mobility device (if existing).

4. Depending on the armrest type of your mobility device, detach the armrest or swivel it up.
5. Now slide onto your new seat.

**NOTE**

- If you do not have sufficient muscle strength, you should ask other persons for help. Use a sliding board, if possible.

4.4 Using the cane holder

If your mobility device is fitted with a cane holder, it can be used for the safe transport of a walking cane, underarm or forearm crutches. The cane holder consists of a plastic container (bottom) and a Velcro fastener (top).

**CAUTION!**

Risk of injury! A walking cane or crutches that are not secured during transport (on the user's lap, for example) can cause injury to the user or other persons!

- During transport, walking canes or crutches should always be secured using a cane holder!

1. Open the upper Velcro fastener.
2. Place the lower end of the walking cane or the crutches in the container at the bottom.
3. The walking cane or the crutches can be secured at the upper end using the Velcro fastener.

5 Driving

 The maximum load capacity that is stated in the technical data only states that the system is designed for this mass in total. However, this does not mean that one can sit a person with this body weight in the mobility device without restrictions. Attention must be paid to the body proportions, such as height, weight distribution, abdominal belt, leg and calf strap and seat depth. These factors have a strong influence on driving features such as tilt stability and traction. The permissible axle loads in particular must be adhered to (refer to 12 Technical data, page 95). It may possibly be necessary to carry out adaptations to the seat system.

5.1 Before driving for the first time

Before you take your first trip, you should familiarise yourself well with the operation of the vehicle and with all operating elements. Take your time to test all functions and driving modes.



NOTE

– If installed, make sure to properly adjust and use the postural belt each time you use the wheelchair.

Sitting comfortably = Driving safely

Before each trip, make sure that:

- You are within easy reach of all operating controls.
- The battery charge is sufficient for the distance intended to be covered.
- The postural belt (if installed) is in perfect order.
- The rear mirror (if installed) is adjusted so you can look behind at all times without having to bend forward or shift your seating position.

5.2 Parking and stationary

When parking your vehicle or if your vehicle is stationary for a prolonged period:

1. Switch the vehicle's power system off (ON-/OFF key).
2. Activate your anti-theft lock, if existing.

5.3 Taking Obstacles

5.3.1 Maximum obstacle height

You can find information about maximum obstacle heights in the chapter entitled 12 Technical data, page 95.

5.3.2 Safety information when ascending obstacles



CAUTION!

Risk of tipping over

- Never approach obstacles at an angle but at 90 degrees as shown below.
- Put your backrest into an upright position before climbing an obstacle.



CAUTION!

Risk of falling out of the mobility device and damage to the mobility device such as broken casters

- Never approach obstacles that are higher than the maximum climbable obstacle height. For the maximum climbable obstacle height, refer to 12 Technical data, page 95.
- If unsure whether the curb climb is possible or not, move away from the obstacle and if possible find another location.

5.3.3 The correct way to overcome obstacles

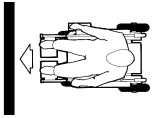

Right

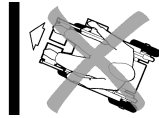

Wrong

Ascending

1. Approach the obstacle or the curb slowly, head-on and at a right angle.
2. Depending on the wheel drive type, stop in one of the following positions:
 - a. In the case of centrally driven mobility devices: 5 - 10 cm before the obstacle.
 - b. For all other drives: approx. 30 - 50 cm in front of the obstacle.
3. Check the position of the front wheels. They must be in driving direction and at right angles to the obstacle.
4. Approach slowly and keep at a consistent speed until the rear wheels have also passed over the obstacle.

Descending

The approach to descend an obstacle is the same as to ascend it with the difference that you need not stop before descending.

1. Descend the obstacle very slowly.

5.4 Driving up and down gradients

For information concerning the maximum safe slope, refer to I2 Technical data, page 95.



CAUTION!

Risk of tipping over

- Only ever drive downhill at a maximum of 2/3 of the top speed. Avoid sudden changes of direction or abrupt braking when driving on slopes.
- Always return the backrest of your seat or the seat tilt (if adjustable seat tilt is available) to an upright position before ascending slopes. We recommend that you position the seat backrest or the seat tilt slightly to the rear before descending slopes.
- Always lower the lifter (if fitted) to its lowest position before ascending or descending a slope.
- Never attempt to ascend or descend a slope on slippery surfaces or where there is a risk of skidding (such as wet pavement, ice etc).
- Avoid trying to get out of the vehicle on an incline or a gradient.
- Always drive straight in the direction the road or path you are on goes, rather than attempting to zigzag.
- Never attempt to turn around on an incline or a slope.



CAUTION!

Braking distance is much longer on a downhill slope than on even terrain

- Never drive down a slope that exceeds the maximum safe slope (refer to I2 Technical data, page 95).



Important information about regulating the actuator functions on gradients

- Your mobility device is fitted with an angular sensor which guarantees tipping stability. The sensor measures the actual angle of the drive unit, and prevents any further decrease in stability by restricting the functionality of the adjustment actuators. If this safety function is activated, the backrest and the seat tilting can only be moved forwards, and the lifter can only be lowered. Reposition your mobility device on level ground so that the actuators can function normally again.

5.5 Using foldable antitippers

Where space is restricted, e.g. in an elevator or when being transported in a car, the mobility device may be too long. Foldable antitippers can be useful here. These can only be operated by an attendant as they are positioned beyond the reach of the user.



CAUTION!

Risk of tipping if the antitippers are not returned to the driving position before moving off

- Always return the antitippers to the driving position before moving off (see the figure below).
- Make sure that the locking pin is fully engaged.

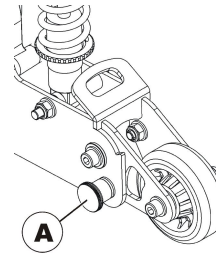

Driving position

Folding the antitipper down:

1. Pull out the locking pin **A** to release the antitipper.
2. Fold the antitipper down.
The mobility device is now shorter.

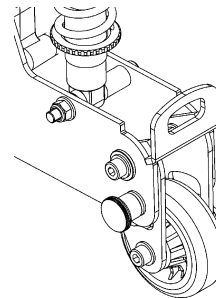

Parking position

Folding the antitipper up:

1. Fold the antitipper upwards until the locking pin audibly engages.
The antitipper is functional again.

5.6 Use on public roads

If you wish to use your mobility device on public roads and lighting is required by national legislation, then your mobility device needs to be fitted with an appropriate lighting system.

Contact your Invacare dealer if you have any questions.

5.7 Pushing the mobility device in freewheel mode

The motors of the mobility device are equipped with automatic brakes, preventing that the mobility device starts rolling out of control when the remote is switched off. When pushing the mobility device manually whilst freewheeling, the magnetic brakes must be disengaged.

-  Pushing the mobility device by hand may require more physical force than expected (more than 100 N). The necessary force nevertheless complies with the requirements of ISO 7176-14:2008.

5.7.1 Disengaging motors (conventional motors)



CAUTION!

Risk of injury from hot motor surfaces

- Avoid touching the motor surfaces when engaging or disengaging.



CAUTION!

Risk of the mobility device running away

- When the motors are disengaged (for push operation whilst freewheeling), the electromagnetic motor brakes are deactivated. When the mobility device is parked, the levers for engaging and disengaging the motors must without fail be locked firmly into the "DRIVE" position (electromagnetic motor brakes activated).



- The motors may only be disengaged by an attendant, not by the user.

This ensures that the motors are only disengaged if an attendant is available to secure the wheelchair and prevent unintended rolling.

Each motor is fitted with an engaging lever which is used to engage or disengage the motor.

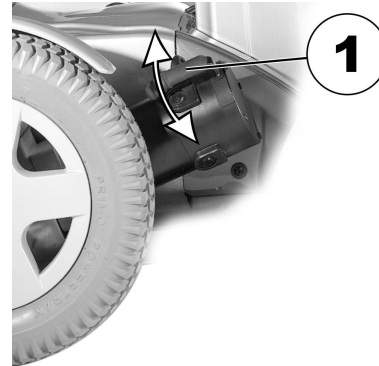

Disengaging the motor:

1. Switch off remote.
2. Pull the engaging lever (I) upwards.
The motor is disengaged.

Engaging the motor:

1. Push the engaging lever down (I).
The motor is engaged. Please note that both motors must always be engaged before driving!

5.7.2 Disengaging the motors (GB motors)



CAUTION!

Risk of injury from hot motor surfaces

- Avoid touching the motor surfaces when engaging or disengaging.



CAUTION!

Risk of the mobility device running away

- When the motors are disengaged (for push operation whilst freewheeling), the electromagnetic motor brakes are deactivated. When the mobility device is parked, the levers for engaging and disengaging the motors must without fail be locked firmly into the "DRIVE" position (electromagnetic motor brakes activated).



NOTE

- The motors may only be disengaged by an attendant, not by the user.
- This ensures that the motors are only disengaged if an attendant is available to secure the mobility device and prevent unintended rolling.

Each motor is fitted with an engaging lever which is used to engage or disengage the motor.

Disengaging the motor:

1. Switch off remote.

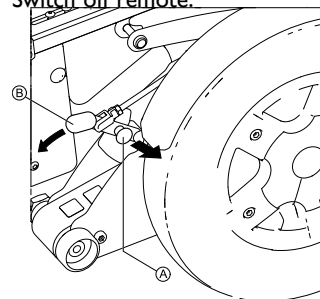

- 2.

Pull the locking pin (A) out and the engaging lever (B) to the rear. The motor is now disengaged.

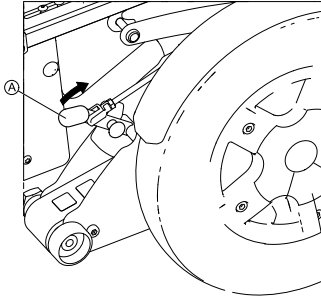
Engaging the motor:

1.

Push the engaging lever Ⓐ forwards.
The motor is now engaged.

 Note that both motors must always be engaged before driving!

6 Adjusting the mobility device to the user's seating posture

6.1 General information on adjusting the wheelchair to the user's seating posture



CAUTION!

Damage to mobility device and accident hazard

It is possible that collisions can occur between mobility device components due to various combinations of adjustment options and their individual settings

- The mobility device is fitted with an individual, multiply adjustable seating system including adjustable legrests, armrests, a headrest or other options. These adjustment options are described in the following chapters. They are used to adapt the seat to the physical requirements and the condition of the user. When adapting the seating system and the seat functions to the user, ensure that no mobility device components collide.



Initial setup should always be done by a healthcare professional. Adjustment by the user is only recommended after they have been given appropriate guidance by the healthcare professional.



Electrical adjustment options

- Please refer to the user manual for your remote for more information on operating electrical adjustment options.



Recaro® seats and AJ Optimist seats

- For more information on a Recaro® seat or AJ Optimist seat, refer to the separate user manuals that come with the seats.

6.2 Adjustment possibility for remote

The following information is valid for all seating systems.



CAUTION!

Risk of the remote being pushed backwards during an accidental collision with an obstacle, such as a doorframe or table, and the joystick being jammed against the armpad if the position of the remote is adjusted and all screws are not completely tightened

This will cause the mobility device to drive forward uncontrollably and potentially injure the mobility device user and any person standing in the way.

- When adjusting the position of the remote, always make sure to tighten all screws securely.
- If this should accidentally happen, immediately switch the mobility device electronics OFF at the remote.

6.2.1 Adjusting the remote for the length of the user's arm (all seat systems)

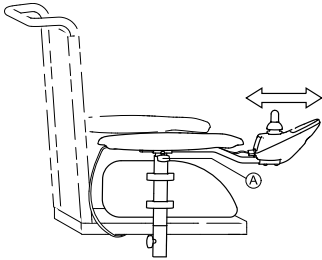

1. Loosen wing bolt (A).
2. Shift the remote forwards or backwards to the desired distance.
3. Retighten the bolt.

6.2.2 Adjusting the height of the remote (only for swing-away remote holders)



Requirements:

- 1 x 6 mm Allen key

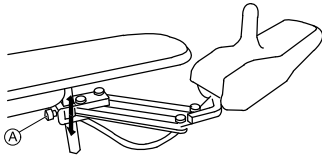

1. Loosen the Allen screw (A).
2. Adjust the remote to the desired height.
3. Re-tighten the Allen screw.

6.2.3 Swivelling the remote to the side

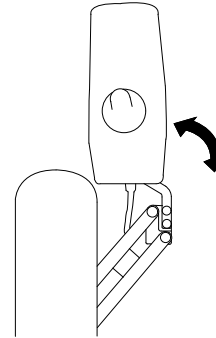

If your mobility device is fitted with a swing-away remote holder, then the remote can be moved away to the side, for example, to drive up close to a table.

6.3 Adjustment options for standard armrests

6.3.1 Changing the arm support position



Requirements:

- 1 x Allen key 3 mm

The arm support has 12 possible positions.

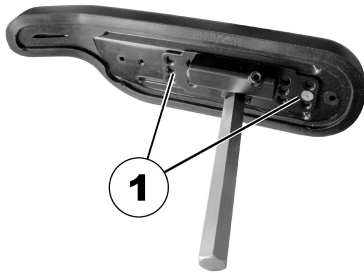

1. To change the position of the arm support, loosen the screw (1) and remove it.
2. The position of the arm support is adjusted by selecting a combination of screw holes in the arm support and the drillholes in the fixing plate.
3. Reposition the screws and tighten.

6.3.2 Setting the height of the armrests



Requirements:

- Allen key 3 mm

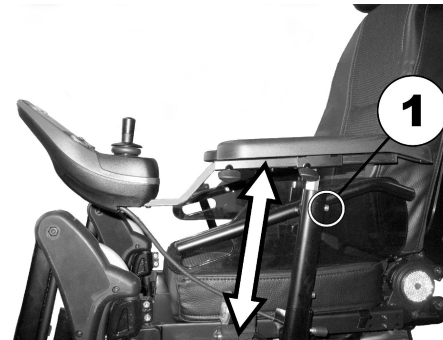

1. Unscrew screw (1) with Allen key.
2. Adjust armrest to required height.
3. Retighten the screw.

6.3.3 Adjusting the width of the armrests



WARNING!

Serious injury hazard if one of the armrests falls out of its bracket because they have been adjusted to a width which exceeds the permissible value!

- The width adjustment is fitted with small stickers with markings and the word "STOP"! The armrests must never be pulled out further than the point at which the word "STOP" is completely legible!
- Always tighten the fixing screws properly once adjustments have been completed!





Requirements:

- Allen key 8 mm

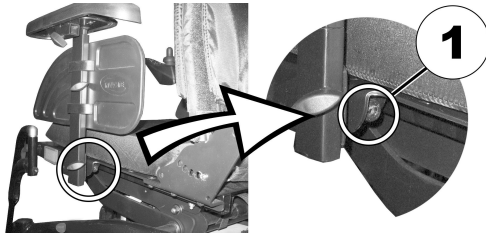

1. Loosen screw (1).
2. Adjust armrest to required position.
3. Retighten the screw.
4. Repeat this procedure for the second armrest.

6.4 Adjustment options for parallel sliding armrests

6.4.1 Setting the height of the parallel sliding armrests

The height of the parallel sliding armrest is set using the armrest angle.



1. Release the knob to adjust the armrest angle (1).

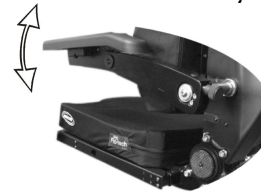

2. Set the angle for the armrest.
3. Retighten the knob.

After adjusting the armrest height, the angle of the armpad needs to be adjusted. Refer to 6.4.2 Adjusting the angle of the armpad on the parallel sliding armrests, page 33.

6.4.2 Adjusting the angle of the armpad on the parallel sliding armrests



Requirements:

- Allen key 5 mm

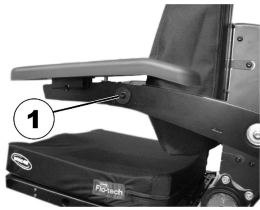

1. Release the bolts to adjust the armrest angle (1) with the allen key.

2.



Set the angle for the armrest.

3. Re-tighten the bolts. Make sure that the Nordlock washers used are re-inserted.

6.4.3 Adjusting the width of the parallel sliding armrests

The parallel sliding armrests can be adapted to the backrest in eight widths.



Pre-requisites:

- 1 x 4 mm Allen key



1. Undo the bolts on both sides of the backrest cover (1). The photograph only shows the bolts on the left-hand side.
2. Remove the backrest cover (2).

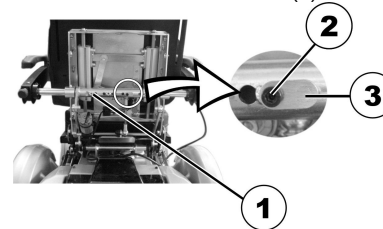

3. On the torque support, loosen the locating pin (3) bolt (2) with the Allen key.
4. Reduce the load on the armrest by raising it slightly and then remove the locating pin.



5. Adjust the armrest width. The possible positions for the armrest are predefined by the drill-holes in the torque support and the armrest axel.
6. Insert the locating pin.
7. Retighten the screw.

8. Repeat the procedure for the other armrest.



9. Replace the backrest cover (2). When doing so, ensure that the recesses in the sides are located correctly.
10. Retighten the bolts on both sides of the backrest cover (1) again. The photograph only shows the bolts on the left-hand side.

6.4.4 Adjusting the mobility of the parallel sliding armrests

The flexibility of the parallel sliding armrest can be adjusted to easier or stiffer.



Requirements:

- Allen key 5 mm

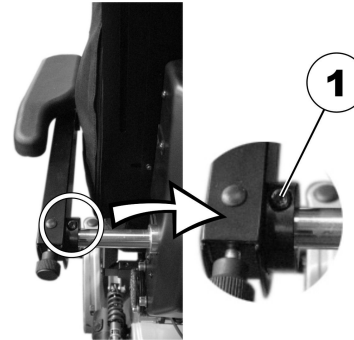

1. To make the armrest easier to move, release the bolt of the adjusting wrench (1) with the Allen key.
2. To make the armrest more difficult to move, tighten the bolt of the adjusting wrench (1) with the Allen key.

6.4.5 Adjusting the arm support positions for the parallel sliding armrests



Requirements:

- Allen key 5 mm

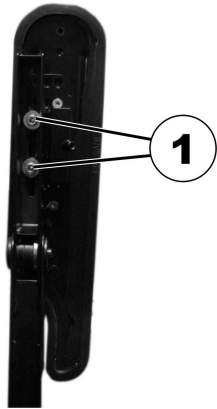

1. Put the armrest in the vertical position.
2. Release the interior bolts (1) with the Allen key.

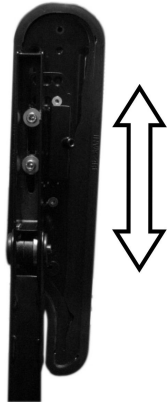

3. Position the armrest horizontally.
4. Re-tighten the bolts. Make sure that the Nordlock washers used are re-inserted.

6.5 Adjustment options for the Modulite seat unit

6.5.1 Adjusting the height of the armrests

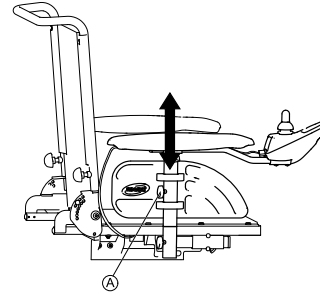

1. Loosen the wing screw (A).
2. Set the armrest to the desired height.
3. Re-tighten the wing screw.

6.5.2 Adjusting the width of the armrests



WARNING!

Serious injury hazard if one of the armrests falls out of its bracket because they have been adjusted to a width which exceeds the permissible value

- The width adjustment is fitted with small stickers with markings and the word "STOP". The armrests must never be pulled out further than the point at which the word "STOP" is completely legible.
- Always tighten the fixing screws properly once adjustments have been completed.



 Depending on the side, the screw is accessible from the front or the rear.



Requirements:

- Allen key 8 mm

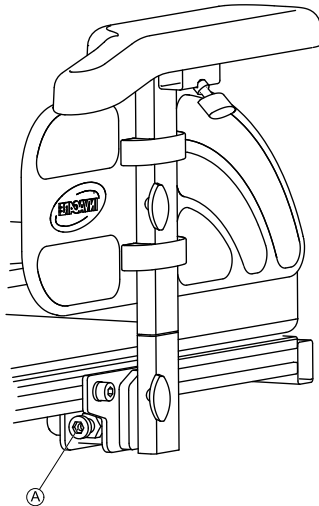

1. Loosen screw **A**.
2. Adjust armrest to required position.
3. Retighten the screw.
4. Repeat this procedure for the second armrest.

6.5.3 Adjusting the position of the armrest in depth



Prerequisites:

- 1 x 6 mm Allen key

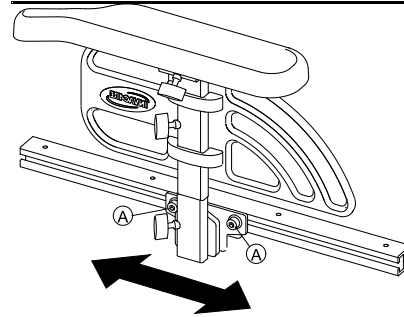

1. Loosen the screws **A** and move the armrest lengthwise.
2. Tighten the screws.

6.5.4 Adjusting the seat width

The telescopic seat support can be adjusted in four stages. The seat width can thus be adjusted together with the adjustable seat plate or the adjustable sling seat.

The description of how the width is adjusted is contained in the service instructions for this mobility device. The service instructions can be ordered from Invacare. However, they contain instructions for specially trained service technicians and describe operations that are not intended for the end user.

6.5.5 Adjusting the seat depth



NOTE

– The seat depth has a major influence on the selection of the center of gravity of the seat. This impacts its dynamic stability. If you make a major change to the seat depth the center of gravity of the seat must also be adjusted. See "Adjusting the center of gravity of the seat" in the service instructions for this mobility device. The service instructions can be ordered from Invacare. However, they contain instructions for specially trained technicians and describe operations that are not intended for the end user.



NOTE

– The numbers on the scale on the seat serve as a guide. They do not stipulate any dimensions such as seat depth in centimeters.



Requirements:

- 1 x 6 mm Allen key

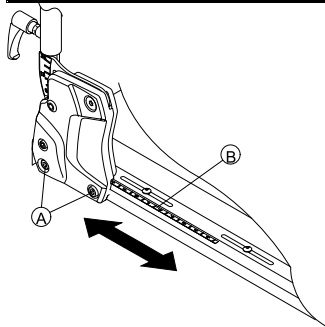

1. On both sides, loosen the bottom backrest screw (A). Do not remove the screws!
2. Move the backrest to the required seat depth. You can adjust the seat depth steplessly. Use scale (B) on the seat as a guide for this purpose. Ensure that the same seat depth is set on both sides.
3. Re-tighten the screws.

6.6 Adjusting the seat angle



CAUTION!

Adjusting the seat tilt or the backrest angle changes the geometry of the mobility device and directly influences its dynamic stability!

– For details regarding dynamic stability, negotiating gradients and obstacles and the correct adjustment of seat tilt or backrest angle, refer to 5.3 Taking Obstacles, page 24 and Driving up and down gradients.

6.6.1 Electrical

Consult the user manual for your remote for information about electrical adjustment.

6.6.2 Manual

The seat angle is adjusted using an adjusting mechanism, which consists of 2 perforated strips which can be pushed against each other. The adjusting mechanism is at the front under the seat frame.

When adjusting the seat angle, ensure that both fixing screws are always used to fix the adjusting mechanism!



NOTE

- Activate the motor brakes (engage motor) before adjusting the seat angle.
- Only adjust the seat angle manually if nobody is sitting in the seat.



Requirements:

- 1 x 6 mm Allen key

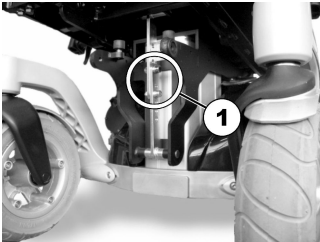

1. Switch the power supply off (ON/OFF key).
2. Unscrew Allen screws (1).
3. Adjust the seat angle by raising or lowering the seat.
4. Insert the Allen screws again and tighten.

6.7 Adjusting the backrest



CAUTION!

Adjusting the seat tilt or the backrest angle changes the geometry of the mobility device and directly influences its dynamic stability!

- For details regarding dynamic stability, negotiating gradients and obstacles and the correct adjustment of seat tilt or backrest angle, refer to 5.3 Taking Obstacles, page 24 and Driving up and down gradients.

6.7.1 Electrical

Consult the user manual for your remote for information about electrical adjustment.

6.7.2 Adjusting the backrest (standard seat) — manually with handscrews

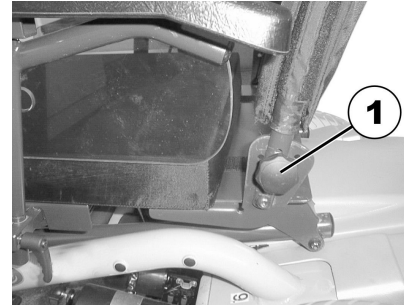

1. Remove the screws (1) on both sides of the backrest that hold it in position.
2. Set the backrest to the desired angle by selecting a combination of one of the two holes in the backrest frame, and one of the six holes in the metal fixation plate.
3. Re-position screws and tighten them.

6.7.3 Adjusting the back seat angle on the Easy-Adapt seating system



1. Adjust the angle by turning the handwheel (1).

6.7.4 Adjusting the height of the backrest (Modulite seat unit)

The following section describes the procedures for adjusting the height of the backrest plate.



NOTE

- The sling back is only available in fixed heights of 48 and 54 cm.



Requirements:

- 1 x 5 mm Allen key

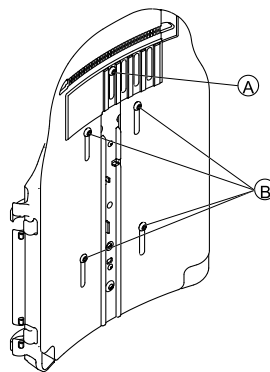

1. Loosen the backrest plate screws (A) and (B).
Do not remove the screws!
2. Move the backrest plate to the required height.
3. Re-tighten the screws.

6.7.5 Adjusting the width of the backrest (Modulite seat unit)

You can adjust the backrest plate width to a certain degree by adjusting the front plate, e.g. in order to adjust the backrest plate in line with the seat cushion. Fairly large adjustments must be made by a service technician to the rear plate and are outlined in the service instructions for this mobility device.



NOTE

- The sling back is only available in two widths of 38-43 cm and 48-53 cm and, under certain circumstances, must be replaced for a width adjustment. For a replacement description, see the service instructions for this mobility device. The service instructions can be ordered from Invacare. However, they contain instructions for specially trained service technicians and describe operations that are not intended for the end user.
- Note that if the sling back width is adjusted the backrest cushion must also be replaced.



Requirements:

- 1 x 5 mm Allen key

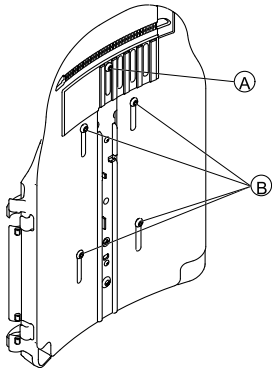

1. Loosen and remove the backrest plate screw (A).
2. Loosen the backrest plate screws (B).
Do not remove the screws!

3. Move the backrest plate halves to the required width.
4. Re-insert screw (A).
5. Re-tighten the screws.

6.7.6 Adjusting the backrest angle (Modulite seat unit)



CAUTION!

Every change to the seat angle and every backrest angle change alters the geometry of the electric wheelchair and affects its dynamic stability

- For more information on stability, overcoming obstacles correctly, driving along inclines and slopes and the correct position of the backrest and seat angles, see the section 5.3 Taking Obstacles, page 24 and Driving up and down gradients.

Width-adjustable backrest



Requirements:

- 1 x 5 mm Allen key

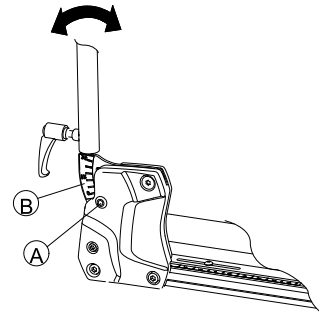

1. On both sides, loosen and remove the upper backrest screw (A).
2. Set the required backrest angle.
Use scale (B) on the backrest for this purpose. Ensure that you set the same angle on both sides.
3. Re-insert and tighten the screw.

Simple backrest



Requirements:

- 1 x 6 mm Allen key

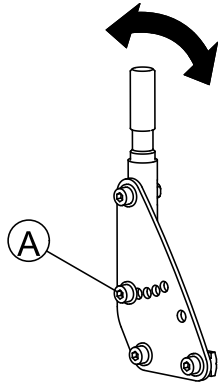

1. On both sides, loosen and remove the middle backrest screw (A).
2. Set the required backrest angle in 7.5° steps.
Ensure that you set the same angle on both sides.
3. Re-insert and tighten the screw.

6.7.7 Adjusting the adaptable backrest padding

There are two ways of adapting the backrest padding.

- Using a snap buckle which is accessible without having to remove the backrest cushion. Please see **Method 1**.

- With adjustment straps which are adjustable using Velcro. Please see **Method 2**.

Method 1

1. Open the Velcro straps on the left-hand side of the backrest cushion.

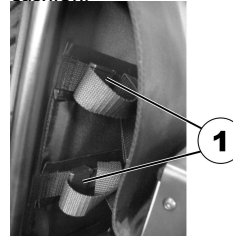

2. Open the individual snap buckles (1) on the adjustment straps.
3. Adjust the strap tension as required and then close the snap buckle again.
4. Close the backrest cushion Velcro fastenings again.

Method 2

6.8 Adjusting the headrest



CAUTION!

Injury hazard during use of the mobility device as a vehicle seat if a headrest is wrongly adjusted or not installed

This can cause the neck to be hyperextended during collisions.

- A headrest must be installed. The headrest optionally supplied for this mobility device by Invacare is perfectly suitable for use during transport.
- The headrest must be adjusted to the user's ear height.

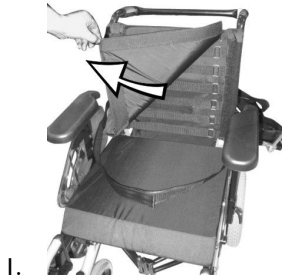

1. Remove the backrest cushion (fixed with Velcro straps) by pulling it up and away so that you can access the adjusting straps.



2. Adjust the tension of the individual straps as required.
3. Replace the backrest cushion.

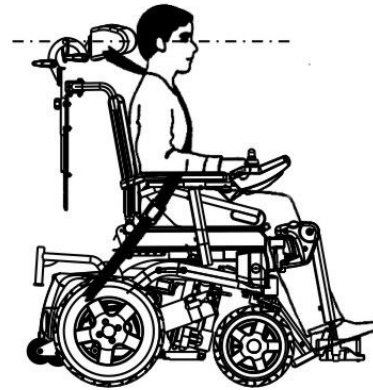

6.8.1 Adjusting the position of the headrest or neckrest

The adjustment of the position is the same for all headrests and neckrests.



Requirements:

- Allen key 5 mm

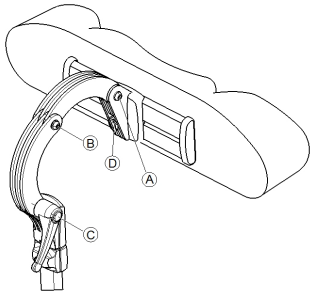

1. Loosen the screws **A** , **B** or the clamping lever **C**.
2. Adjust the headrest or neckrest to the required position.
3. Retighten screws and clamping lever.
4. Loosen the Allen screw **D**.
5. Slide the headrest left or right to the required position.
6. Retighten the Allen screw.

6.8.2 Adjusting the height of the headrest or neckrest

The adjustment of the height is the same for all headrests and neckrests.

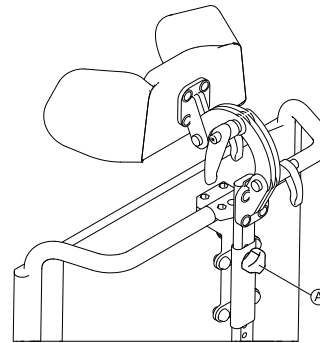

1. Loosen the knob **A**.
2. Adjust the headrest or neckrest to the required height.
3. Retighten the knob.

6.8.3 Adjusting the cheek supports



1. Push the cheek supports inward or pull them out to the required position.

6.9 Postural belts

A postural belt is an option which can either be fixed to the mobility device ex-works or can be retrofitted by your specialist dealer. If

your mobility device is fitted with a postural belt, your specialist dealer will have informed you about fitting and usage.

The postural belt is used to help the mobility device user keep an optimum sitting position. Correct use of the belt assists the user in sitting securely, comfortably and well-positioned in the mobility device, especially for such users who do not have such a good sense of balance while sitting.



NOTE

- We recommend using the postural belt whenever the mobility device is used. The belt should be tight enough to ensure that you are sitting comfortably and that your body is in the correct sitting position.

6.9.1 Types of postural belts

Your wheelchair can be fitted with the following postural belt types ex-works. If your wheelchair has been fitted with a different belt to those listed below, please ensure that you have received the manufacturer's documentation with regard to correct fitting and use.

Belt with metal buckle, adjustable one side



Belt can only be adjusted on one side which can result in the buckle not sitting centrally.

Belt with metal buckle, adjustable both sides



Belt can be adjusted on both sides. This means that the buckle can be centrally positioned.

6.9.2 Adjusting the postural belt correctly

1. Ensure that you are sitting correctly, which means that you are sitting right at the back of the seat, your pelvis is positioned erect and as symmetrically as possible, not to the front, to the side or at one edge of the seat.
2. Position the postural belt so that your hipbones can be easily felt above the belt.
3. Adjust the belt length using one of the adjustment aids described above. The belt should be adjusted so that you can fit a flat hand between the belt and your body.
4. The buckle should be positioned as centrally as possible. In doing so, carry out adjustments on both sides as much as possible.
5. Check your belt every week to ensure that it is still in good working condition, to ensure it has no damage or wear, and that it is fixed properly to the mobility device. If the belt is only fastened with a bolted connection, ensure that the connection has not loosened or come undone. You can find more information about maintenance work on belts in the service manual, which is available from Invacare.

6.10 The Lifter

The electric lifter is operated from the remote. Refer to the remote manual for more information.



Information regarding operation of the lifter at temperatures of less than 0 °C

- Invacare mobility aids are fitted with safety mechanisms that prevent capacity overload of the electronic components. At operating temperatures below freezing point this can, in particular, lead to the lifter actuator being shut down after approx. 1 second operating time.
- The lifter can be raised or lowered gradually by repeatedly operating the joystick. In many cases this generates sufficient heat for the actuator to operate as normal.



NOTE - speed limiter

- The lifter is fitted with sensors which reduce the mobility device speed as soon as the lifter is raised above a certain point.
- This takes place to guarantee the tipping stability of the mobility device and to avoid damage to the legrests.
- If the speed limit is activated, a corresponding blink code is displayed on the remote or a reduced drive level is set automatically. Please refer to the remote manual for more information.
- To reapply normal speed, run the lifter down until the status display stops blinking.



CAUTION!

Risk of tipping, if the speed limiter sensors fail when the lifter is raised

- If you find that the speed reduction function is not working when the lifter is raised, do not drive with the lifter raised and immediately contact an authorized Invacare dealer.

6.11 Adjusting the trunk support (Easy-Adapt seating system)

The trunk supports can be adjusted in width, height and depth.

6.11.1 Adjusting the width

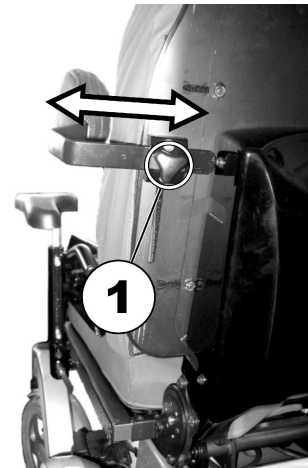

1. Loosen the handscrews (1).
2. Adjust the trunk support to the required width.
3. Retighten the handscrews again.

6.11.2 Adjusting the height



Requirements:

- Allen key 5 mm



1. Undo the height adjustment Allen screws (1).
2. Set the trunk support to the required height.
3. Retighten the screws.

6.11.3 Adjusting the depth



Requirements:

- Allen key 5 mm



1. Open the zip.
2. Undo the screws (1) for the depth adjustment.
3. Adjust the trunk support to the required position.
4. Retighten the screws.
5. Close the zip again.

6.12 Adjusting and removing the tray



CAUTION!

Injury hazard or material damage if a mobility device which is fitted with a table is transported in a vehicle

- If a table is fitted, always remove it before transporting the mobility device.



6.12.1 Laterally adjusting the tray

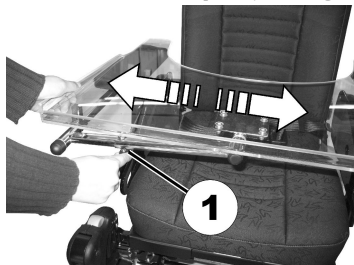

1. Loosen the wing-screw (1).
2. Adjust the tray towards the left or right.
3. Re-tighten wing-screw.

6.12.2 Adjusting the depth of the tray / removing the tray

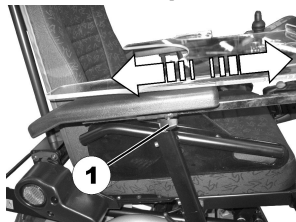

1. Loosen the wing-screw (1).
2. Adjust the table to the desired depth (or remove it entirely).
3. Re-tighten the screw.

6.12.3 Swinging the tray away to the side

The tray can be swivelled up and away to the side to allow the user to get in and out of the mobility device.



CAUTION!

Risk of injury! When the tray is raised it does not lock in place in this position!

- Do not tilt the tray up and leave it leaning in this position.
- Never attempt to drive with the tray tilted up.
- Always lower the tray in a controlled manner.

6.13 Seat support

6.13.1 Adjusting seat width



NOTE

- Also refer to the following chapter entitled 6.13.2 Adjusting the seat depth, page 49.
- The seat width can be adjusted in stages between 380 and 530 mm.



Requirements:

- 4 mm Allen key

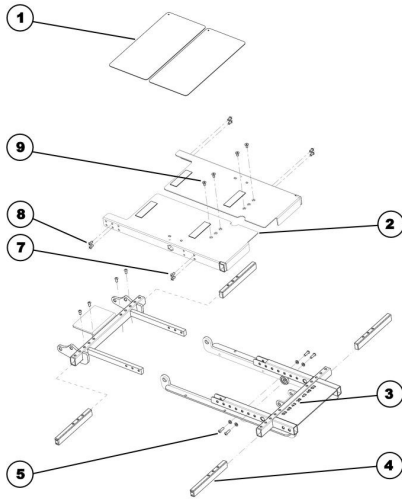

Exploded drawing of seat support

1. Remove the seat cushion.
2. Remove the cover plates (1).
3. Undo the two Allen screws (6) at the rear on the crossmember and remove them.
4. Undo the two Allen screws (9) at the front on the seat support plate and remove them.
5. Loosen the four Allen screws (7) and (8) which are located at the front and back to the sides of the seat support plate to release tension so that the plate can be moved more easily. Do not, however, remove these screws completely.
6. Pull or push the seat support plate (2) the required width. A scale (3) has been fitted to the bottom part of the seat support. Use this scale to read off the seat width in centimeters.

7. Repeat these operations on the other side of the seat.
8. Now tighten all the screws again.

6.13.2 Adjusting the seat depth



NOTE

- Also refer to the previous chapter entitled 6.13.1 Adjusting seat width, page 48.
- The seat depth can be adjusted in stages between 380 and 530 mm.



Requirements:

- 4 mm Allen key
- 8 mm jaw spanner
- oblique pliers
- cable binder



NOTE

- Particular holes in the seat support must be used to the screws depending on the required seat depth. It may also be necessary to replace the seat support plate.
- I. Please use the following figures and the table to determine which holes need to be used for the required seat depth, and therefore whether the seat support plate needs to be replaced or not.

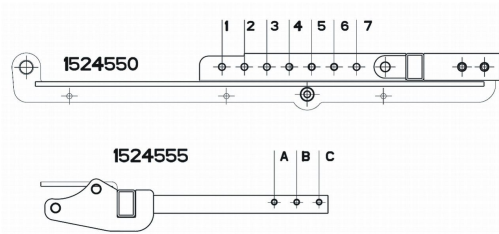

Seat depth in cm	Holes used in front seat frame order no.: 1524550	Holes used in rear seat frame order no.: 1524555	Seat support plate required
38	6 & 7	A & B	SHORT
41	5 & 7	A & C	order no. 1526437
43	4 & 6	A & C	
43	4 & 6	A & C	MEDIUM
46	3 & 5	A & C	order no. 1526438
48	2 & 4	A & C	
48	2 & 4	A & C	LONG
51	1 & 3	A & C	order no. 1526439
53	1 & 2	B & C	

- Adjust the seat depth as described in the following chapter:
 - If the seat support plate does not need to be replaced, please refer to chapter 6.13.3 Adjusting the seat depth without replacing the seat support plate, page 50.
 - If the seat support plate does need to be replaced, please refer

to chapter 6.13.4 Adjusting the seat depth with replacing the seat support plate, page 51.

6.13.3 Adjusting the seat depth without replacing the seat support plate

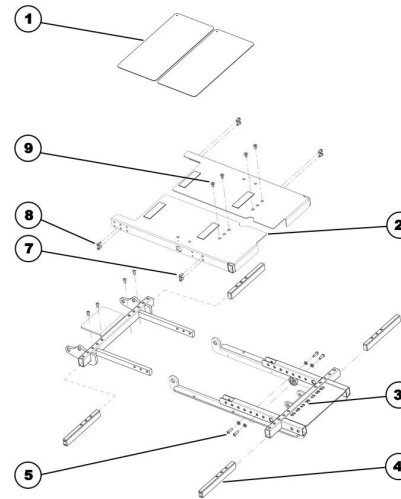

Exploded drawing of seat support

Disassembly:

- Remove the armrests.
- Remove the seat cushion.
- Remove the cover plates (1).
- Undo and remove the two Allen screws (8) which are located on the side at the rear of the seat support plate, and connect these to the crossmembers (4).

5. Repeat these operations on the other side of the seat.
6. Undo and remove the two Allen screws (5) including washers.

Assembly:

1. Pull the seat support to the required length so that the Allen screws (5) can be inserted in the holes in accordance with the table (see above).
2. Insert the Allen screws (5) including washers again and tighten them.
3. Fit the two Allen screws (8) which are located at the rear of the seat support, and connect them with the crossmembers (4). You must be using other holes within the 3 hole pairs for the screws than you did during dismantling.
4. Refit all the parts you have removed.

6.13.4 Adjusting the seat depth with replacing the seat support plate

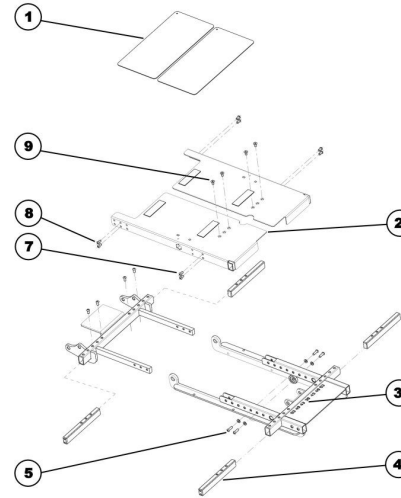

Exploded drawing of seat support

Disassembly:

1. Remove the legrests.
2. Remove the armrests.
3. Remove the seat cushion.
4. Remove any cable ties which hold cables from the remote or lighting which have been fitted. Remove the cables from any clips which have been glued on.
5. Undo the cap nuts on the headlight holders with an 8 mm jaw spanner.

6. Place the headlights including their holders safely on the rear section of the battery box cover.
7. Remove the cover plates (1).
8. Undo the two Allen screws (9) at the front on the seat support plate and remove them.
9. Undo the two Allen screws (7) which are located on the side at the front of the seat support plate, and connect these to the crossmembers (4).
10. Undo the two Allen screws (8) which are located on the side at the rear of the seat support plate, and connect these to the crossmembers (4).
11. Remove the seat support plate (2).
12. Repeat these operations on the other side of the seat.
13. Undo and remove the two Allen screws (5) including washers.

Assembly:

1. Pull the seat support to the required length so that the Allen screws (5) can be inserted in the holes in accordance with the table (see above).
2. Insert the Allen screws (5) including washers again and tighten them.
3. If necessary, replace the seat support plate (2) in accordance with the table (see above).
4. Put the seat support plate (2) back in position.
5. Fit the two Allen screws (7) which are located at the front of the seat support, and connect them with the crossmembers (4).
6. Fit the two Allen screws (8) which are located at the rear of the seat support, and connect them with the crossmembers (4). It may be necessary to use other holes in the 3 hole pairs for the screws than you did while dismantling the old plate.
7. Fit the two Allen screws (9) at the front of the seat support plate.
8. Refit all the parts you have removed.

6.14 Backrest unit with ergonomic length compensation (Easy-Adapt)

6.14.1 Adjusting the width



NOTE

- Also refer to the previous chapter entitled 6.13.1 Adjusting seat width, page 48.
- The seat can be adjusted in stages between 380 and 530 mm.



Requirements:

- 4 mm Allen key

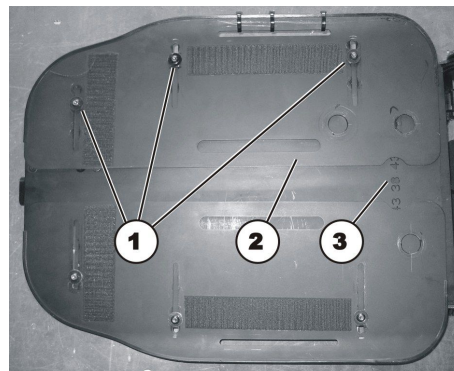

1. Remove the backrest cushion.
2. Loosen the three Allen screws (1). Do not, however, remove these screws completely.
3. Push the plate (2) as far as required until the required width in cm can be read off the scale (3).
4. Tighten the three Allen screws again.

5. Repeat these operations on the other backrest plate.
6. Attach a backrest cushion of the required width.

6.15 Adjusting the suspension and the shock absorbance

Taking the user weight into account, the Storm® 4 suspension and shock absorbance can be individually adjusted to a softer setting for more comfort and less shock absorbance or a harder setting for a harder suspension and more support. These adjustments should only be carried out by trained specialists. Contact your authorized Invacare specialist dealer.



NOTE

- It is easier to adjust the suspension and shock absorbance if there is no-one sitting in the chair.

6.15.1 Adjusting the suspension (Storm⁴ X-plore only)

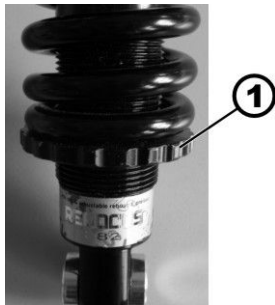

Softer



Harder

Adjusting the suspension harder

1. Rotate the adjustable spring plate (1) as shown in the illustration in order to adjust the suspension harder.

Adjusting the suspension softer

1. Rotate the adjustable spring plate (1) as shown in the illustration in order to adjust the suspension softer.

6.15.2 Disabling the suspension and shock absorbance

You can disable the suspension and shock absorbance so that they are no longer working.

I.

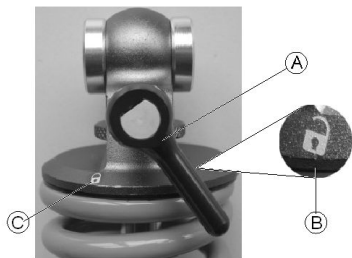

Move the lever **A** from "Active" ("open lock" symbol, **B**) to "Inactive" ("closed lock" symbol, **C**).



The suspension and shock absorbance are disabled.

6.15.3 Adjusting the shock absorbance

In the case of the Storm⁴ X-plore, the shock absorbance can be quickly and simply adjusted using a wheel on the springs:

- If you set the shock absorbance harder, you get a more direct response to the ground for more sportive driving with a less swinging chassis.
- The softer you set the shock absorbance, the softer the response to the ground is and the more comfortable the driving is.



left



right

The works setting for the wheel is the middle position. From here, the shock absorbance can be adjusted to be softer (-) or harder (+) in 10 levels in either direction.

Adjusting the shock absorbance harder

6.16 Adjusting or removing the luggage carrier



Risk of damage as a result of collisions

Parts of the mobility device may be damaged if the luggage carrier collides with the seat during seat angle or backrest adjustment.

- Ensure that the luggage carrier is out of the range of both seat angle and backrest adjustment.



Risk of breakage due to excessive load

The luggage carrier can break if too great a load is applied.

- The maximum permitted load on the luggage carrier is 10 kg.

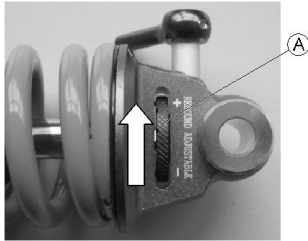

1. Turn the wheel (A) to the plus sign, to set harder shock absorbance.
10 is the hardest level of shock absorbance.

Adjusting the shock absorbance softer

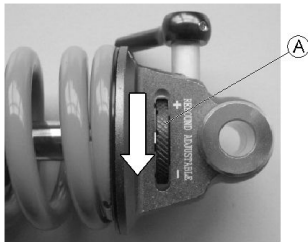

1. Turn the wheel (A) to the minus sign, to set softer shock absorbance.
10 is the softest level of shock absorbance.

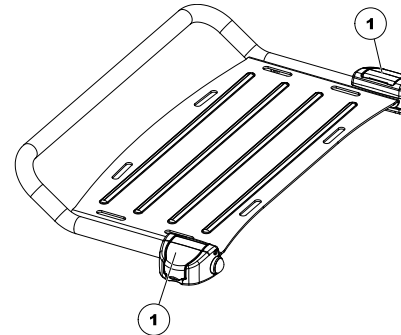

1. Open the clamp levers (1) of the luggage carrier bracket.
2. Slide the luggage carrier forward or backward or remove it.
3. Close the clamp levers of the luggage carrier bracket.

6.17 Using the KLICKfix adapter

Your mobility device can be fitted with the mini-adapter from the Rixen + Kaul KLICKfix system. To this you can attach various accessories such as the cellphone case supplied by Invacare, which you can use to transport your cellphone, sports glasses etc.

- ! **Risk posed by unsecured accessories**
 - Accessories can fall off and get lost if they are not properly secured.
 - Check that the accessory is correctly locked in and seated securely every time you use the mobility device.

- ! **Risk of breakage due to excessive load**
 - The KLICKfix adapter can break if too great a load is applied.
 - The maximum permitted load on the KLICKfix adapter is 1 kg.

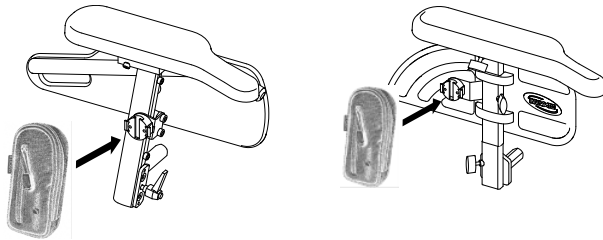

Securing the accessory:

- I. Push the accessory into the KLICKfix adapter.
The accessory locks in securely.

Removing the accessory:

- I. Press the red button and remove the accessory.

The adapter can turn in 90° steps, allowing you to attach an accessory from any of four different directions. Please refer to the installation instructions which are available from your Invacare dealer or directly from Invacare.

More information on the KLICKfix system is available at <http://www.klickfix.com>.

7 Adjusting footrests and legrests

7.1 Center-mounted legrests — Electric legrest

Consult the user manual for your remote for information about electrical adjustment.

The electric legrest can be lowered completely to assist getting out of the wheelchair. To do so, move your seat into the correct position by lowering the lifter or by means of a negative seat angle (tilted slightly to the front).

7.1.1 Lowering the electric legrest completely to assist getting out of the wheelchair



Misuse may destroy the legrest

– Please read and carefully follow the instructions below.

Getting in/out of the wheelchair

1. Set the lifter and tilt to a comfortable position.



2. Put your feet on the footplate and pull the lever (1). The footplates will move smoothly down to the floor.
3. Now you can get in/out of the wheelchair.

Lifting up the footplates

1. You are sitting in the wheelchair.



2. Put your feet beside the footplates



3. Pull the lever (1).
The footplates rise up automatically.
4. Let go the lever (1) and put your feet on the footplates.

! **Risk of damage to the legrest**

- Always make sure that the footplates are fully raised to the uppermost position before adjusting the angle of the legrest.
- Disregarding this advice will cause damage to your legrest.

Adjusting the legrest



1. Now you can adjust the angle of the legrest.

7.2 Center-mounted legrests — Adjustable legrest

7.2.1 Adjusting the angle



Requirements:

- 1 x 10 mm open-ended spanner

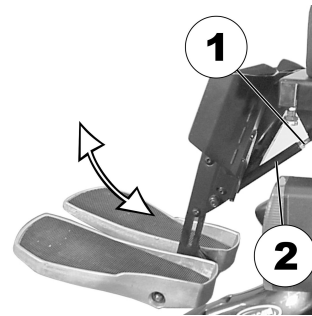

1. Use the open-ended spanner to loosen the counter nut (1).
2. Move the legrest to the desired position by turning the spindle (2).
3. Tighten the counter nut.

7.2.2 Adjusting the length of the legrest



Requirements:

- 1 x 5 mm socket head spanner

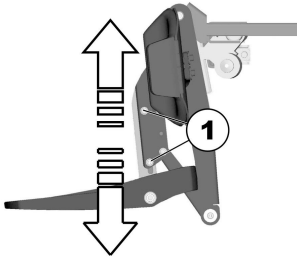

1. Use the socket head spanner to loosen the fastening screws (1).
2. Slide the foot support to the desired height.
3. Tighten the fastening screws.

7.2.3 Adjusting the calf pad to the calf width of the user

The calf pad of the legrest can be adapted to the user's calf width by bending apart or together.

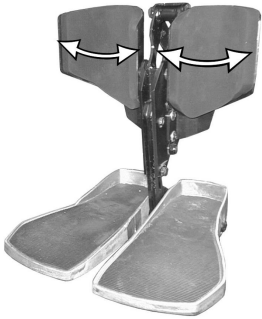

1. Bending the calf pad to the desired width.

7.2.4 Adjusting the angle of the foot plate



Requirements:

- 1 x 5 mm socket head spanner

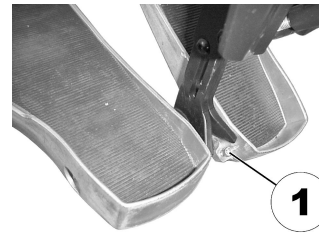

1. Fold up the foot plates in order to access the adjusting screws.
2. Use the socket head spanner to adjust the adjusting screws (1).
3. Fold the foot plate down again.

7.3 Vari-F footrest

7.3.1 Swivelling the footrest/legrest outward and/or removing

The small unlocking button is located on the upper section of the footrest/legrest. When the footrest/legrest is unlocked, it can be swivelled inward or outward when getting into the wheelchair as well as being removed completely.

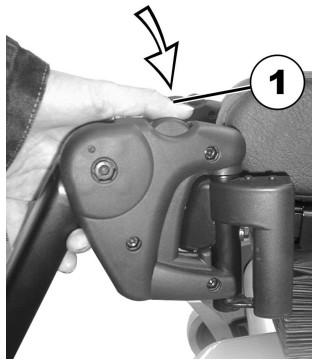

1. Press the unlocking button (1) and swivel the footrest/legrest outward.
2. Remove the footrest/legrest in an upward direction.

7.3.2 Setting the angle



CAUTION!

Risk of injury due to incorrect adjustment of the footrests and legrests

- Before and during every journey it is imperative to ensure that the legrests contact neither the caster wheels nor the ground



Requirements:

- 1 x 6 mm Allen key

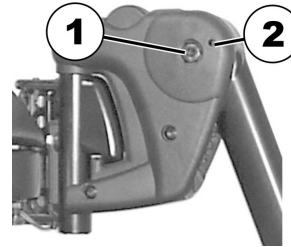

1. Loosen the screw (1) using the Allen key.
2. If the footrest cannot be moved after loosening the screw, position a metal pin in the designated borehole (2) and use a hammer to knock on this lightly. The clamping mechanism in the interior of the footrest will be released by this. Repeat the procedure from the other side of the footrest if necessary.

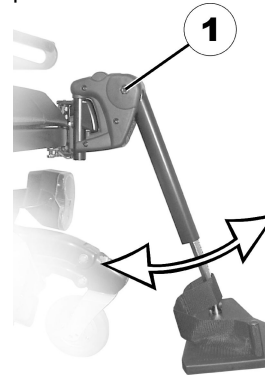

3. Loosen the screw (1) using the Allen key.
4. Set the desired angle.
5. Re-tighten the screw.

7.3.3 Setting the end stop of the footrest



Requirements:

- 1 x 6 mm Allen key
- 1 x 10 mm open-ended spanner

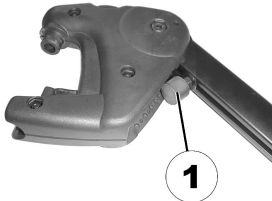

1.

The end position of the footrest is determined by means of a rubber stop (1).

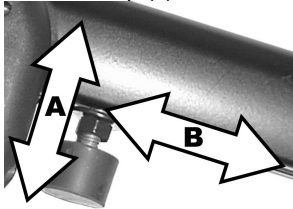

2.

The rubber stop can be screwed in or out (A) or pushed up or down (B).

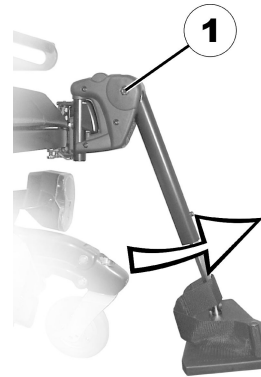

3.

Use the Allen key to loosen the screw (1) and swivel the footrest upward in order to access the rubber stop.

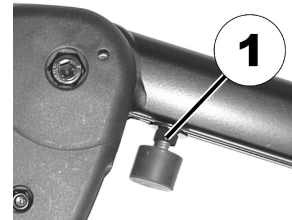

4.

Use the open-ended spanner to loosen the counter nut (1).

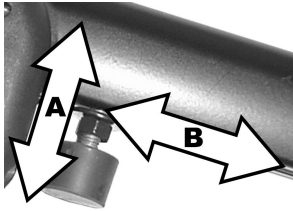

- 5.
6. Move the rubber stop to the desired position.
6. Re-tighten the counternut.

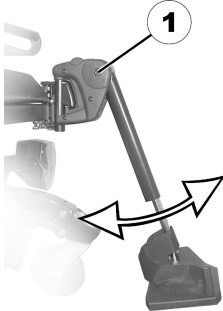

- 7.
8. Move the footrest to the desired position.
8. Re-tighten the screw.

7.3.4 Adjusting the length of the footrest



CAUTION!
Risk of injury due to incorrect adjustment of the footrests and legrests

- Before and during every journey it is imperative to ensure that the legrests contact neither the caster wheels nor the ground



Requirements:

- 1 x 5 mm Allen key

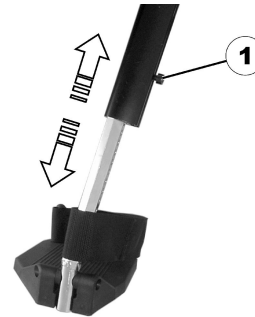

1. Use the spanner to loosen the screw (1).
2. Adjust to the desired length.
3. Re-tighten the screw.

7.4 Vari-A legrests

7.4.1 Swivelling the footrest/legrest outward and/or removing

The small unlocking button is located on the upper section of the footrest/legrest. When the footrest/legrest is unlocked, it can be swivelled inward or outward when getting into the wheelchair as well as being removed completely.

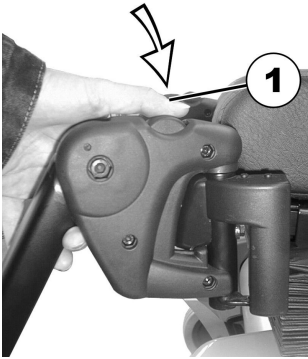

1. Press the unlocking button (1) and swivel the footrest/legrest outward.
2. Remove the footrest/legrest in an upward direction.

7.4.2 Setting the angle



CAUTION!

Risk of injury due to incorrect adjustment of the footrests and legrests

- Before and during every journey it is imperative to ensure that the legrests contact neither the caster wheels nor the ground

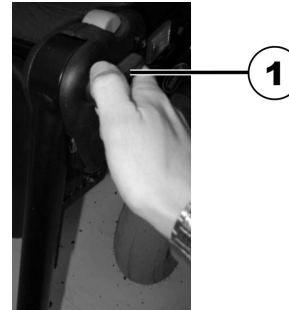

1.

Loosen the locking knob (1) counter-clockwise at least one turn.



2.

Hit the knob to release the locking mechanism.



3. Set the desired angle.



4. Turn the knob clockwise to tighten it.

7.4.3 Setting the end stop of the legrest



Requirements:

- 1 x 10 mm open-ended spanner

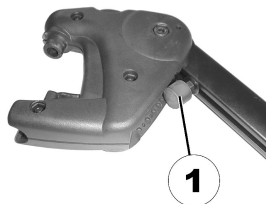

1. The end position of the legrest is determined by means of a rubber stop (1).

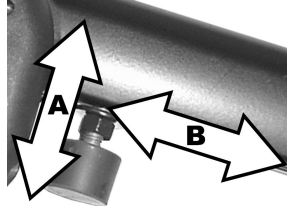

2. The rubber stop can be screwed in or out (A) or pushed up or down (B).

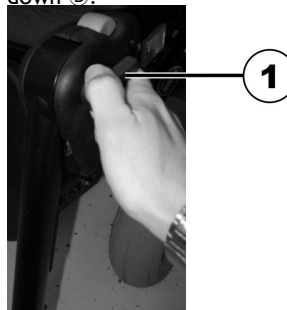

3. Loosen the locking knob (1) counter-clockwise at least one turn.



4. Hit the knob to release the locking mechanism.

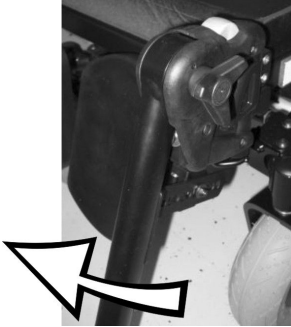

5. Swivel the legrest upward in order to access the rubber stop.

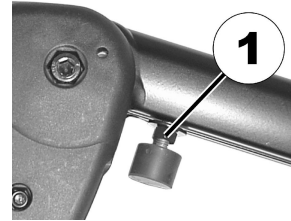

6. Use the open-ended spanner to loosen the counter nut (1).

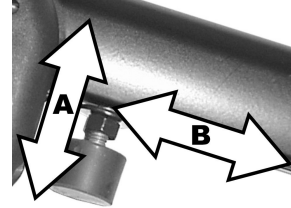

7. Move the rubber stop to the desired position.
8. Re-tighten the counter nut.



9. Move the legrest to the desired position.
10. Re-tighten the locking knob.

7.4.4 Adjusting the length of the legrest



CAUTION!

Risk of injury due to incorrect adjustment of the footrests and legrests

- Before and during every journey it is imperative to ensure that the legrests contact neither the caster wheels nor the ground



Requirements:

- 1 x 5 mm Allen key

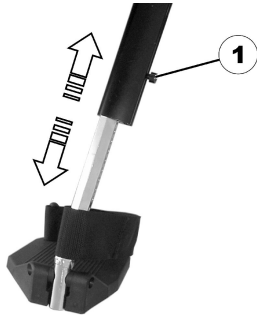

1. Use the spanner to loosen the screw (1).
2. Adjust to the desired length.
3. Re-tighten the screw.

7.4.5 Adjusting the depth of the calf pad

The depth of the calf pad can be adjusted via the holding plate. The holding plate hole combinations allow 5 different depth settings.



Requirements:

- 1 x 10 mm open-ended spanner



1. Use the open-ended spanner to loosen the nut (1) and remove.
2. Adjust to the desired depth. Please observe that the round holes are intended for the calf pad retaining screw and the oblong holes for the aglet without thread.
3. Screw the nut back on and tighten.

7.4.6 Adjusting the height of the calf pad



Requirements:

- 1 x 4 mm Allen key



1. Use the Allen key to loosen the screws (1).
2. Adjust to the desired position.
3. Re-tighten the screws.

7.4.7 Unlocking and swivelling the calf pad backward when alighting



- 1.
2. Press the calf pad straight down.



Unlock the legrest and swivel outward.
The calf pad swivels backward on its own.



3. Lift leg over the heel strap and place on the ground.

7.4.8 Adjusting the angle-adjustable foot plate



Requirements:

- 1 x 5 mm Allen key
-

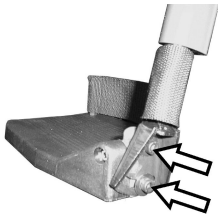

1. Use the Allen key to loosen both set screws on the foot plate.
2. Adjust to the desired angle.
3. Re-tighten the screws.

7.4.9 Adjusting the angle- and depth-adjustable foot plate



Requirements:

- 1 x 5 mm Allen key
-

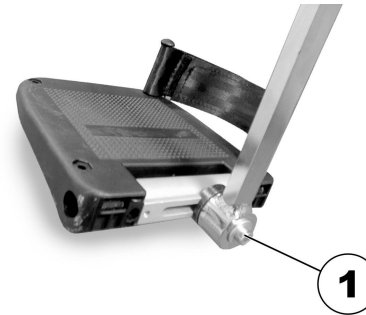

1. Use the Allen key to loosen the set screw on the foot plate (1).
2. Adjust the foot plate to the desired angle or depth.
3. Re-tighten the screw.

7.5 ADE legrests

7.5.1 Swivelling the legrest outward and/or removing

The small unlocking button is located on the upper section of the legrest. When the legrest is unlocked, it can be swivelled inward or outward when getting into wheelchair as well as being removed completely.

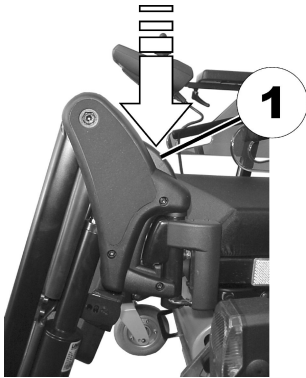

1. Press the unlocking button (1) and swivel the legrest outward.
2. Remove the legrest in an upward direction.

7.5.2 Setting the angle



CAUTION!
Risk of crushing

– Do not reach inside the swivelling range of the legrest.



CAUTION!
Risk of injury due to incorrect adjustment of the footrests and legrests

– Before and during every journey it is imperative to ensure that the legrests contact neither the caster wheels nor the ground

The electrically height-adjustable legrests are operated using the remote. Refer to the separate user manual for your remote for more information.

7.5.3 Adjusting the length of the legrest



CAUTION!

Risk of injury due to incorrect adjustment of the footrests and legrests

– Before and during every journey it is imperative to ensure that the legrests contact neither the caster wheels nor the ground



Requirements:

- 1 x 10 mm open-ended spanner

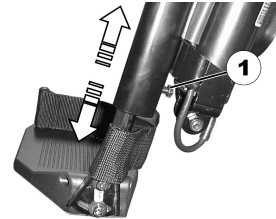

1. Use the spanner to loosen the screw (1).
2. Adjust to the desired length.
3. Re-tighten the screw.

7.5.4 Adjusting the depth of the calf pad

The depth of the calf pad can be adjusted via the holding plate. The holding plate hole combinations allow 5 different depth settings.



Requirements:

- 1 x 10 mm open-ended spanner

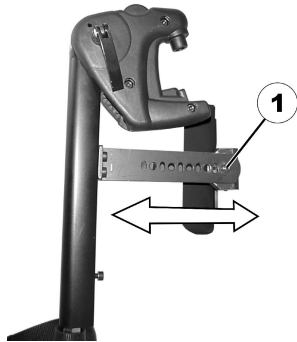

1. Use the open-ended spanner to loosen the nut (1) and remove.
2. Adjust to the desired depth. Please observe that the round holes are intended for the calf pad retaining screw and the oblong holes for the aglet without thread.
3. Screw the nut back on and tighten.

7.5.5 Adjusting the height of the calf pad



Requirements:

- 1 x 4 mm Allen key
-

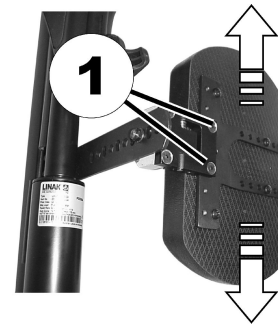

1. Use the Allen key to loosen the screws (1).
2. Adjust to the desired position.
3. Re-tighten the screws.

7.5.6 Unlocking and swivelling the calf pad backward when alighting



- 1.
2. Press the calf pad straight down.



Unlock the legrest and swivel outward.
The calf pad swivels backward on its own.



3. Lift leg over the heel strap and place on the ground.

1529686-P

7.5.7 Adjusting the angle-adjustable foot plate



Requirements:

- 1 x 5 mm Allen key

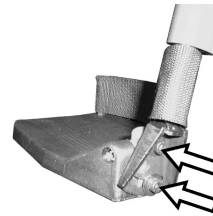

1. Use the Allen key to loosen both set screws on the foot plate.
2. Adjust to the desired angle.
3. Re-tighten the screws.

7.5.8 Adjusting the angle- and depth-adjustable foot plate



Requirements:

- 1 x 5 mm Allen key



1. Use the Allen key to loosen the set screw on the foot plate (1).
2. Adjust the foot plate to the desired angle or depth.
3. Re-tighten the screw.

7.6 Angle-adjustable footboard



Requirements:

- Torx spanner T25
- Allen key 5 mm



1. Release the screws (1) with the Torx spanner and remove.
2. Adjust to required width.
3. Retighten the bolts.
4. Glue the anti-slip rubber mat to the footboard.



5. Loosen the locking screw(1) on both sides with the mm Allen key.
6. Adjust the footboard to the required angle.
7. Retighten the bolts.

7.7 Adjusting the width of side-mounted legrests



Requirements:

- 13 mm open-ended spanner

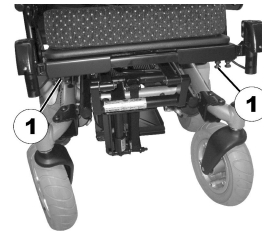

The screws that allow width adjustment of side-mounted legrests are located under the seat (1).

1. Loosen the screws using the open-end spanner.
2. Adjust the legrest to the desired position.
3. Re-tighten the screws.

8 Electrical system

8.1 Electronics protection system

The vehicle drive electronics is fitted with an overload protection.

If the drive is severely overloaded over a long period (for example, during steep climbs) and, above all, at simultaneous high external temperatures, the electronic system can overheat. In this case, the vehicle performance is gradually reduced until it comes to a standstill. The status display shows a corresponding flash code (please refer to the user manual for your remote). If you switch the drive electronics off and then on again, the error message is deleted and the electronics can be switched on again. It can however take up to five minutes until the electronics has cooled down enough for the drives to apply their full performance.

If the drive is blocked due to an insurmountable obstacle, for example, a curb or similar which is too high, and the driver attempts to run the drive for more than 20 seconds against this obstacle, the electronic system switches the drives off to avoid damage. The status display shows a corresponding flash code (please refer to the user manual for your remote). If you switch the drive electronics off and then on again, the error message is deleted and the electronics can be switched on again.



NOTE

– A defective main fuse may be replaced only after checking the entire electric system. An Invacare specialised dealer must perform the replacement. You can find information on the fuse type in 12 Technical data, page 95.

8.2 Batteries

Power is supplied by two 12 V batteries. The batteries are maintenance-free and only need regular charging.

In the following, you find information on how to charge, handle, transport, store, maintain, and use batteries.

8.2.1 General information on charging

New batteries should always be fully charged once before their first use. New batteries will be at their full capacity after having run through approx. 10 - 20 charging cycles (break-in period). This break-in period is necessary to fully activate the battery for maximum performance and longevity. Thus, range and running time of your mobility device could initially increase with use.

Gel/AGM lead acid batteries do not have a memory effect as NiCd batteries.

8.2.2 General instructions on charging

Follow the instructions listed below to ensure safe use and longevity of the batteries:

- Charge 18 hours prior to initial usage.
- We recommend charging the batteries daily after every discharge even after partly discharge, as well as each night over night. Depending on the level of discharge, it can take up to 12 hours until the batteries are fully charged again.
- When the battery indicator reached the red LED range, charge the batteries for 16 hours minimum, neglecting the charge complete display!
- Try to provide a 24 hour charge once a week to make sure that both batteries are fully charged.
- Do not cycle your batteries at a low state of charge without regularly recharging them fully.

- Do not charge your batteries under extreme temperatures. High temperatures above 30 °C are not recommended for charging as well as low temperatures below 10 °C.
- Use only charging devices in Class 2. This class of chargers may be left unattended during charging. All charging devices which are supplied by Invacare comply with these requirements.
- You cannot overcharge the batteries when using the charger supplied with your vehicle, or a charger that has been approved by Invacare.
- Protect your charger from sources of heat such as heaters and direct sunlight. If the battery charger overheats, charging current will be reduced and the charging process delayed.

8.2.3 How to charge the batteries

Refer to the user manuals for your remote and battery charger for the position of the charging socket and further information about charging the batteries.



WARNING!

Risk of explosion and destruction of batteries if the wrong battery charger is used

- Only ever use the battery charger supplied with your vehicle, or a charger that has been approved by Invacare.

Risk of electric shock and damage to the battery charger if it gets wet

- Protect the battery charger from water.
- Always charge in a dry environment.

Risk of short circuit and electric shock if the battery charger has been damaged

- Do not use the battery charger if it has been dropped or damaged.

Risk of electric shock and damage to the batteries

- NEVER attempt to recharge the batteries by attaching cables directly to the battery terminals.

Risk of fire and electric shock if a damaged extension cable is used

- Only ever use an extension cable if it is absolutely necessary. In case you must use one, make sure it is in good condition.

Risk of injury if using the mobility device during charging

- DO NOT attempt to recharge the batteries and operate the mobility device at the same time.
- DO NOT sit in the mobility device while charging the batteries.

1. Switch off the mobility device.
2. Connect the battery charger to the charger socket.
3. Connect the battery charger to the power supply.

8.2.4 How to disconnect the batteries after charging

1. Once charging is complete, first disconnect the battery charger from the power supply, then disconnect the plug from the remote.

8.2.5 Storage and Maintenance

Follow the instructions listed below to ensure safe use and longevity of the batteries:

- Always store the batteries fully charged.
- Do not leave the batteries in a low state of charge for an extended length of time. Charge a discharged battery as soon as possible.
- In case your mobility device is not used for a longer period of time (that is more than two weeks), the batteries must be charged at least once a month to maintain a full charge and always be charged before use.
- Avoid hot and cold extremes when storing. We recommend to store batteries at a temperature of 15 °C.
- Gel and AGM batteries are maintenance-free. Any performance issues should be handled by a properly trained mobility device technician.

8.2.6 Instructions on using the batteries



CAUTION!

Risk of damaging the batteries.

- Avoid ultra-deep discharges and never drain your batteries completely.

- Pay attention to the Battery Charge Indicator! Charge the batteries when the Battery Charge Indicator shows that battery charge is low.
How fast the batteries discharge depends on many circumstances, such as ambient temperature, condition of the surface of the road, tire pressure, weight of the driver, way of driving and utilisation of lighting, if fitted.
- Try to charge the batteries always before you reach the red LED range.
The last 3 LED (two red and one orange) mean a remaining capacity of about 15 %.
- Driving with flashing red LED's means an extreme stress for the battery and should be avoided under normal circumstances.
- When only one red LED is flashing, the Battery Safe feature is enabled. From this time, speed and acceleration is reduced drastically. It will allow you to move the mobility device slowly out of a dangerous situation before the electronic finally cuts off. This is deep discharging and should be avoided.
- Be aware that for temperatures below 20 °C, the nominal battery capacity starts to decline. For example, at -10 °C the capacity is reduced to about 50 % of the nominal battery capacity.
- To avoid damaging the batteries, never allow them to be fully discharged. Do not drive on heavily discharged batteries if it is not absolutely necessary, as this will strain the batteries unduly and shorten their life expectancy.
- The earlier you recharge the batteries, the longer they live.

- The depth of discharge affects the cycle life. The harder a battery has to work, the shorter is its life expectancy.
Examples:
 - One deep discharge stresses the same as 6 normal cycles (green /orange display off).
 - The battery life is about 300 cycles at 80 % discharge (first 7 LED off), or about 3000 cycles at 10 % discharge (one LED off).



NOTE

- The number of LED can vary depending on the remote type.

- Under normal operation, once a month the battery should be discharged until all green and orange LED are off. This should be done within one day. A 16 hour charge afterwards is necessary as reconditioning.

8.2.7 Transporting batteries

The batteries supplied with your electric vehicle are not hazardous goods. This classification is based on the German GGVS Hazardous Goods Road Transport Ordinances, and the IATA/DGR Hazardous Goods Rail Transport / Air Transport Ordinances. Batteries may be transported without restrictions, whether by road, rail or by air. Individual transport companies have, however, guidelines which can possibly restrict or forbid certain transport procedures. Please ask the transport company regarding each individual case.

8.2.8 General instructions on handling the batteries

- Never mix and match different battery manufactures or technologies, or use batteries that do not have similar date codes.
- Never mix gel with AGM batteries.

- Always have your batteries installed by a properly trained mobility device technician. They have the necessary training and tools to do the job safely and correctly.

8.2.9 How to handle damaged batteries correctly



CAUTION!

Corrosion and burns from acid leakage if batteries are damaged

- Remove clothes that have been soiled by acid immediately.

After contact with skin:

- Immediately wash affected area with lots of water.

After contact with eyes:

- Immediately rinse eyes under running water for several minutes; consult a physician.

- Always wear safety goggles and appropriate safety clothing when handling damaged batteries.
- Place damaged batteries in an acid-resistant receptacle immediately after removing them.
- Only ever transport damaged batteries in an appropriate acid-resistant receptacle.
- Wash all objects that have come into contact with acid with lots of water.

Disposing of dead or damaged batteries correctly

Dead or damaged batteries can be given back to your dealer or directly to Invacare.

9 Maintenance

9.1 Maintenance introduction

The term “Maintenance“ means any task performed to ensure that a medical device is in good working order and ready for use as intended. Maintenance encompasses different areas, such as everyday care and cleaning, inspection checks, repair tasks and refurbishment.



NOTE

- Have your vehicle checked once a year by an authorised Invacare dealer in order to maintain its driving safety and roadworthiness.

9.2 Cleaning the mobility device

When cleaning the mobility device, pay attention to the following points:

- Only use a damp cloth and gentle detergent.
- Do not use any abrasive or scouring agents.
- Do not subject the electronic components to any direct contact with water.
- Do not use any high-pressure cleaning devices.

Disinfection

Spray or wipe disinfection using a tested and recognised product is permitted. A list of the current permitted disinfectants is available from the Robert Koch Institute at <http://www.rki.de>.

9.3 Inspection checks

The following table lists inspection checks that should be performed by the user and their intervals. If the mobility device fails to pass one of the inspection checks, refer to the chapter indicated or contact your authorised Invacare dealer. A more comprehensive list of

inspection checks and instructions for maintenance work can be found in the service manual for this device, which can be obtained from Invacare. That manual, however, is intended to be used by trained and authorized service technicians, and describes tasks which are not intended to be performed by the user.

9.3.1 Before each use of the mobility device

Item	Inspection check	Action
Horn	Check of correct mode of operation.	Contact your dealer
Lighting unit	Check of correct operating mode for all lights such as indicators, headlights and rear lights.	Contact your dealer

Item	Inspection check	Action
Batteries	Check of battery charging status. Please refer to the remote manual for information about battery charging status display.	Charge the batteries (see chapter 8.2.3 How to charge the batteries, page 75).
Foldable antitippers	Check whether the antitippers are in the driving position. Check whether the locking pin is fully engaged.	Bring the antitippers into the driving position (see chapter 5.5 Using foldable antitippers, page 26). Make sure that the locking pin engages.

9.3.2 Weekly

Item	Inspection check	Action
Armrests /side parts	Check that armrests are firmly attached in their holders and do not wobble.	Tighten the screw or clamping lever that holds the armrest (see chapter 6.2 Adjustment possibility for remote, page 30). Contact your dealer.
Tires (pneumatic)	Check that the tires are undamaged.	Contact your dealer.

Item	Inspection check	Action
	Check that the tires are inflated to the correct pressure.	Inflate the tire to the correct pressure (see chapter 12 Technical data, page 95). Repair the inner tube if you have a flat tire (see chapter 9.4 Repair Instructions, page 82) or contact your dealer to have it repaired.
Tires (puncture-proof)	Check that the tires are undamaged.	Contact your dealer.

9.3.3 Monthly

Item	Inspection check	Action
All upholstered parts	Check for damage and wear.	Contact your dealer.
Removable legrests	Check whether the legrests can be fixed securely and whether the loosening mechanism is properly operable (refer to 7 Adjusting footrests and legrests, page 57).	Contact your dealer.

Item	Inspection check	Action
	Check that all adjustment options function properly (refer to 7 Adjusting footrests and legrests, page 57).	Contact your dealer.
Casters	Check that casters rotate and swivel freely.	Contact your dealer.

Item	Inspection check	Action
Drive wheels	Check that the drive wheels rotate without wobbling. It is easiest to have someone stand behind the mobility device and observe the drive wheels as you drive away from them to do this.	Contact your dealer.
Electronics and connectors	Check all cables for damage and all connecting plugs for snug fit.	Contact your dealer.

9.3.4 Inspections performed

It is confirmed by stamp and signature that all jobs listed in the inspection schedule of the service and repair instructions have been properly performed. The list of the inspection jobs to be performed can be found in the service manual which is available through Invacare.

Delivery Inspection	1st Annual Inspection
Stamp of authorized dealer / Date / Signature	Stamp of authorized dealer / Date / Signature
2nd Annual Inspection	3rd Annual Inspection

Stamp of authorized dealer / Date / Signature	Stamp of authorized dealer / Date / Signature
4th Annual Inspection	5th Annual Inspection
Stamp of authorized dealer / Date / Signature	Stamp of authorized dealer / Date / Signature

9.4 Repair Instructions



Important information about maintenance work tools!

– Some maintenance work which is described in this manual and can be carried out by the user without problems require the correct tools for proper work. If you do not have the correct tool available we do not recommend that you try to carry out the relevant work. In this case, we urgently recommend that you contact an authorised specialist workshop.

The following are instructions on maintenance and repairs that can be performed by the user. For the specifications of spare parts please see 12 Technical data, page 95, or consult the service manual, available from Invacare (in this connection please see the addresses and phone numbers at the end of this user manual). In case you require assistance, please contact your Invacare dealer.



CAUTION!

Risk of damage or injury if the vehicle is accidentally set into motion during repairs

- Switch the power off (ON/OFF Button).
- Engage the motors.
- Secure the vehicle against rolling away by placing wedges under the wheels.



CAUTION!

Risk of hands and feet being crushed by the weight of the wheelchair

- Pay attention to your hands and feet.
- Use the correct lifting techniques.

9.4.1 Repairing tire punctures (wheel rim type 3.00-8")



CAUTION!

Risk of injury

If the wheel has been insufficiently tightened during assembly, it can become loosened during driving.

- When reassembling the drive wheels, tighten the Allen screws at a torque of 30 Nm.
- Secure all screws using a suitable blocker (e.g. Loctite 243).



Requirements:

- Allen key – open-ended spanner 6 mm
- Torque spanner
- Repair kit for tire repair **or** a new inner tube
- Talcum powder
- Screw blocker Loctite (e.g. Loctite 243)

Removing the wheel

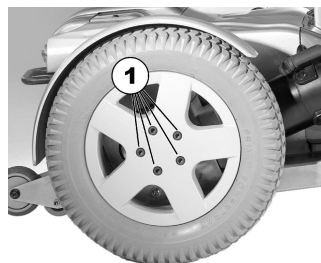

1. Block up the vehicle (place wooden blocks under frame).
2. Unscrew the screw (1).
3. Remove the wheel from the hub.

-  Re-assembly is done in reverse order. Ensure that the tire is replaced on the same side and in the same travel direction as it was previously mounted.

Repairing the flat tire



CAUTION! **Risk of explosion**

The wheel will explode if you do not let the air out of the tire before removing the wheel.

- Always let the air out of the tire before removing it (press in the pin in the middle of the valve).



1. Unscrew valve cap.
2. Depressurise tire completely by pressing in the pin in the valve.
3. Remove the 5 cylinder head screws (back of the wheel, 2)
4. Remove the rim halves from the tire.
5. Remove the inner tube from the tire.
6. Repair inner tube and replace, or insert new.

-  If the old inner tube is to be repaired and re-used, and has become wet during repair, you can make replacement easier by sprinkling the inner tube with a little talcum powder.

7. Insert the wheel rim halves from outside into the tire.
8. Pump a little air into the inner tube.

1529686-P

9. Reinsert the cylinder head screws and tighten to 10 Nm. Avoid crushing the inner tube!
10. Ensure that the tire outer is seated correctly.
11. Pump the tire up to the prescribed pressure.
12. Ensure that the tire outer is seated correctly again.
13. Screw the valve cap back on.
14. Refit the wheel.

9.4.2 Repairing punctures (drive wheel with GB motor and pneumatic tires)



CAUTION! **Risk of injury**

If the wheel has been insufficiently tightened during assembly, it can become loosened during driving.

- When reassembling the drive wheels, tighten the Allen screws at a torque of 25 Nm.



Requirements:

- Open-ended spanner 6 mm
- Torque wrench
- Repair kit for tire repair **or** a new inner tube.
- Talcum powder
- Screw blocker Loctite (e.g. Loctite 243)

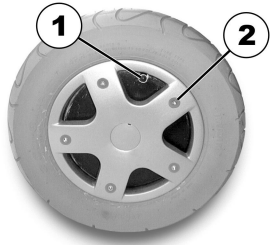

1. Block up the vehicle (place wooden blocks under frame).
2. Unscrew valve cap.
3. Depressurize tire by pressing in the pin in the valve (1).
4. Unscrew 5 screws (2).
5. Remove the wheel rim halves.
6. Remove the inner tube from the tire.

 If the old inner tube is to be repaired and re-used, and has become wet during repair, you can make replacement easier by sprinkling the inner tube with a little talcum powder.

7. Repair inner tube and replace, or insert new.
8. Replace the inner tube in the tire.
9. Insert the wheel rim halves once again.
10. Insert the screws and tighten slightly.
11. Pump a little air into the inner tube.
12. Tighten the screws to 25 Nm.
13. Ensure that the tire outer is seated correctly.
14. Pump the wheel up to its prescribed air pressure. Refer to 12 Technical data, page 95.
15. Check that the tire is seated correctly once again.
16. Screw the valve cap back on.

9.4.3 Repairing a flat front tire (pneumatic tire 3.00-6")



Requirements:

- Allen key 5 mm
- Open-end spanner 24 mm
- Repair kit for inner tubes **or** a new inner tube.
- Talcum powder

Remove the wheel

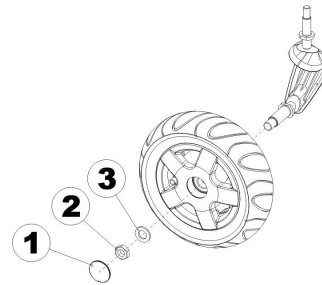

1. Jack the vehicle up and place a block of wood underneath it to prop it up.
2. Remove the plastic cap (1).
3. Loosen and remove the nut (2) using the open-end spanner.
4. Remove the washer (3).
5. Take the wheel off of the fork assembly.



Re-assembly is done in reverse order. Make sure that the wheel is put back on the same side it was on, and that it runs in the same direction it did before it was removed.

Repair the flat tire

**CAUTION!****Risk of injury**

If the wheel has been insufficiently tightened during assembly, it can become loosened during driving.

- When reassembling the drive wheels, tighten the Allen screws at a torque of 30 Nm.
- Secure all screws using a suitable blocker (e.g. Loctite 243).

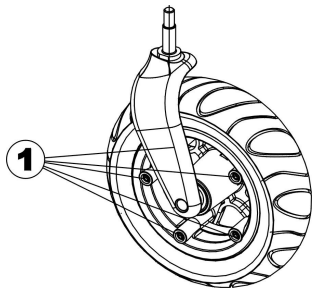

1. Remove the valve cap.
2. Let the air out of the tire completely by pressing the pin in the centre of the valve in.
3. Remove the 5 Allen screws (1)
4. Take the tire and the inner tube off of the rim halves.
5. Repair the inner tube and re-fit, or replace it with a new one.

 In case the old inner tube is to be repaired and used again, and it happens to get wet during repair, then it is easier to re-fit it if you powder it lightly with talcum powder.

6. Place the rim halves in the tire from the outside.
7. Pump up the tire a little.

8. Re-position the Allen screws in the rim and tighten them firmly. Make sure the inner tube does not get pinched between the rims halves!
9. Check to make sure that the tire is squarely in place on the rim.
10. Pump up the tire to the recommended tire pressure.
11. Check to make sure that the tire is still squarely and snugly in place on the rim.
12. Screw the valve cap back on.
13. Refit the wheel.

10 Transport

10.1 Transport — General information



CAUTION!

Injury hazard or material damage if a mobility device which is fitted with a table is transported in a vehicle

- If a table is fitted, always remove it before transporting the mobility device.



10.2 Transferring the mobility device to a vehicle



WARNING!

The mobility device is in danger of tipping over if it is transferred to a vehicle while the driver is still seated in the mobility device

- Transfer the mobility device without the driver whenever possible.
- If the mobility device with the driver has to be transferred to a vehicle using a ramp, ensure that the ramp does not exceed the maximum safe slope (refer to 12 Technical data, page 95).
- If the mobility device has to be transferred to a vehicle using a ramp that does exceed the maximum safe slope (refer to 12 Technical data, page 95), a winch must then be used. An attendant can then safely monitor and assist the transfer process.
- Alternatively, a platform lift may be used.
- Ensure that the total weight of the mobility device including the user does not exceed the maximum permitted total weight for the ramp or platform lift.
- The mobility device should always be transferred to a vehicle with the backrest in an upright position, the seat lifter lowered and the seat tilt in the upright position (refer to Driving up and down gradients).

1. Drive or push your mobility device into the transport vehicle using a suitable ramp.

10.3 Use of the mobility device as a seat in a vehicle



The following section does not apply to models or configurations which may not be used as a vehicle seat. These are identified by the following labels on the lashing eyes:



WARNING!

Risk of death or serious injury

If a mobility device is secured using a 4-point tie-down system available from a third party supplier and the curb weight of the mobility device exceeds the maximum weight for the system, death or serious injury to the user and potential nearby occupant.

- The actual weight of this wheelchair can exceed 140 kg. A suitably strong and proven 4-point tie-down system is available from Unwin Safety Systems. Contact Unwin for more information on how to obtain such a system in your country.

Unwin Safety Systems

Phone: + 44 (0)1935 827740

Email: sales@unwin-safety.co.uk

Web: www.unwin-safety.com

- If compatible, use the Docking Station system (available separately) as an alternative way to safely use this wheelchair as a vehicle seat. Contact Invacare for more details.



WARNING!

Risk of injury

Safety restraint devices must only be used when the wheelchair user's weight is 22 kg or more.

- When the user weight is lower than 22 kg, do not use the wheelchair as a seat in a vehicle.

**CAUTION!**

There is a risk of injury if the mobility device is not properly secured during use as a vehicle seat.

- If possible, the user should always leave the mobility device to use a vehicle seat and the safety belts provided with the vehicle.
- The mobility device should always be anchored facing in the transport vehicle's intended direction of travel.
- The mobility device must always be secured in accordance with the mobility device and anchoring system manufacturers' user manual.
- Always remove and secure any accessory parts fixed to the mobility device such as chin controls or tables.
- If your mobility device is fitted with an angle adjustable backrest, then it must be placed in an upright position.
- Fully lower elevated legrests, if fitted.
- Fully lower the seat lifter, if fitted.

**CAUTION!**

Risk of injury exists if a mobility device that is not fitted with leak-proof batteries is transported in a vehicle.

- Only ever use leak-proof batteries.

**CAUTION!**

Risk of injury or damage to the mobility device or to the transporting vehicle, if the legrests are in a raised position while the mobility device is used as a vehicle seat.

- Always completely lower height-adjustable legrests, if fitted.



In order to use a mobility device as a motor vehicle seat, it needs to be fitted with attachment points to enable anchoring in the motor vehicle. These accessories may be included in the standard scope of mobility device order and delivery in some countries (UK for example), but may also be obtained from Invacare as an option in other countries.

This mobility device complies with the requirements of ISO 7176-19:2001 and may be used as a vehicle seat in connection with an anchoring system that has been checked and approved in accordance with ISO 10542. The transporting vehicle must be professionally converted to anchor the mobility device. Contact your vehicle's manufacturer for more information.

The mobility device has undergone a crash test in which it was anchored in the transporting vehicle's direction of travel. Other configurations were not tested. The crash test dummy was secured using pelvic and upper body safety belts. Both types of safety belt should be used in order to minimize the risk of injuries to head or upper body.

It is imperative that the mobility device is inspected by an authorized dealer before being used again after being involved in a crash. Alterations to the mobility device anchoring points may not be carried out without the manufacturer's permission.

10.3.1 How the mobility device is anchored in a vehicle for use as a vehicle seat

The mobility device is fitted with four anchoring points, which are labelled with the symbol shown on the right. Snap hooks or belt loops can be used for fixation.



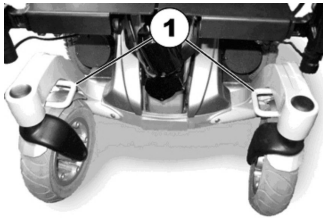

Front

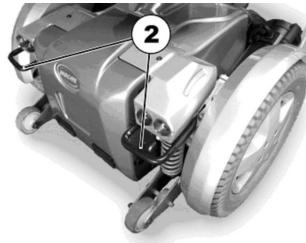

Rear

1. Secure the mobility device at the front (1) and at the rear (2) with the anchoring system belts.
2. Secure the mobility device by tensioning the belts in accordance with the anchoring system manufacturer's user manual.

10.3.2 How the user is secured within the wheelchair



CAUTION!

There is a risk of injury if the user is not properly secured within the mobility device

- Even if the mobility device is fitted with a postural belt, this is no substitute for a proper safety belt which complies with ISO 10542 in the transport vehicle. Always use the safety belt installed in the transport vehicle.
- Safety belts must be in contact with the user's body. They must not be held at a distance from the user's body using parts of the mobility device such as armrests or wheels.
- Safety belts must be pulled as tightly as possible without causing the user discomfort.
- Safety belts must not be positioned while twisted.
- Ensure that the third seat belt anchorage point is not fixed directly to the vehicle floor, but to one of the vehicle uprights.



CAUTION!

Injury hazard during use of the mobility device as a vehicle seat if a headrest is wrongly adjusted or not installed

- This can cause the neck to be hyperextended during collisions.
- A headrest must be installed. The headrest optionally supplied for this mobility device by Invacare is perfectly suitable for use during transport.
 - The headrest must be adjusted to the user's ear height.

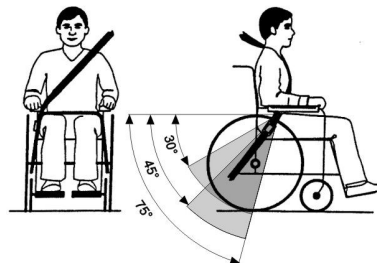
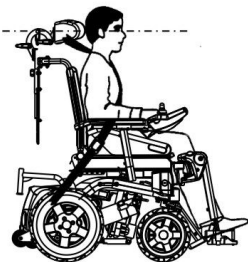

Seat belts may not be held at a distance from the user's body using parts of the wheelchair such as armrests or wheels.

The pelvic belt should be positioned in the area between the user's pelvis and thighs so that it is unobstructed and not too loose. The ideal angle of the pelvic belt to the horizontal is between 45° and 75°. The maximum permissible angle is between 30° and 75°. The angle should never be less than 30°!

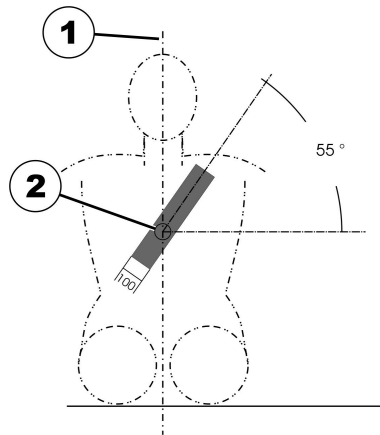

The safety belt installed in the transporting vehicle should be applied as shown in the illustration above.

- 1) Center line of the body
- 2) Center of the sternum

10.4 Transporting the mobility device without occupant



CAUTION! Risk of injury

– If you are unable to fasten your mobility device securely in a transport vehicle, Invacare recommends that you do not transport it.

- Before transporting your mobility device, make sure the motors are engaged and that the remote is switched off. Invacare strongly recommends that you additionally disconnect or remove the batteries. Refer to Removing the batteries.
- Invacare strongly recommends securing the mobility device to the floor of the transporting vehicle.

10.4.1 Opening the rear cover

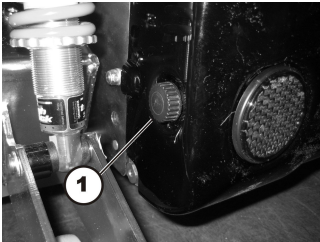

Removing the rear cover:

1. Loosen and remove the two knobs (1) on the left and right side of the rear casing.
2. Lift the rear cover carefully. The front part of the cover is held at the top by a Velcro strip. This must also be released.

Fitting the rear cover:

1. Fit the parts in the reverse order.
2. Tighten the two knobs by hand.

10.4.2 Making the batteries accessible



WARNING!

Fire and burn hazard due to short circuit at battery poles

- DO NOT short-circuit the battery poles with a tool or metal parts of the wheelchair.
- Make sure that the battery pole caps are attached at all times when you are not working on the battery poles.



CAUTION!

Risk of crushing

- The batteries are very heavy. There is a risk of hand injury.
- Be aware that the batteries are very heavy.
 - Handle the batteries with care.



Be careful when handling small parts such as screws and washers during disassembly. Place the small parts down in a way that makes it easy to reassemble them in the correct order.

1. Remove the rear cover as described in chapter **Opening rear cover**.

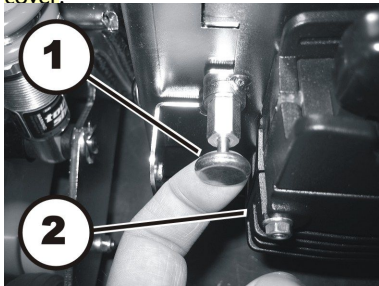

2. Pull the snap fitting (1) beside the power module backwards.
3. Lift the power module with the holder and remove the mounting from the battery cap flap.
4. Place the power module and the mounting on top of the battery compartment or actuator module, if applicable.

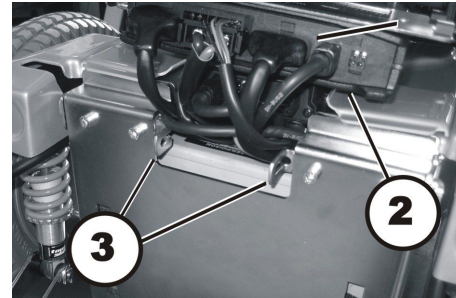

5. Press both locking mechanisms (3) in and open the battery flap.

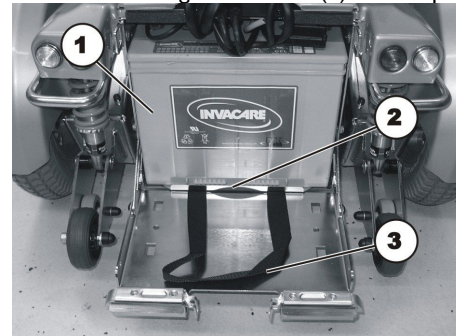

6. Use the strap (3) to pull the batteries (1) and the battery carrier (2) forward as far as possible.

10.4.3 Removing/Installing the batteries



Requirements:

- 11 mm socket spanner

Removing the batteries:

1. Make the batteries accessible as described in chapter 10.4.2 Making the batteries accessible, page 91.

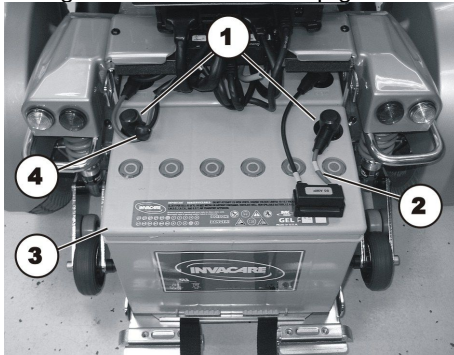

2. Remove the pole caps (1) from the accessible battery (3).
3. Remove the pole screws located under the pole caps using an 11-mm socket spanner.
4. Remove the connection cable (4) and the fuse cable (2).
5. Lift the battery from the battery carrier.
6. Pull the second battery forward using its strap.
7. Disconnect the cables of the second battery as well.
8. Lift the second battery from the battery carrier.

Fitting the batteries:

1. Fit the batteries in the reverse order.
2. Ensure that the connectors and sockets in the battery compartment are fitted correctly. There is a polarity diagram in the rear cover.

11 After Use

11.1 Refurbishment

The product is suitable for refurbishment. Actions to be carried out:

- Cleaning and disinfection. Refer to 9 Maintenance, page 78.
- Inspection according to service plan. Consult service instructions, available from Invacare.
- Adaptation to the user. Refer to 6 Adjusting the mobility device to the user's seating posture, page 30.

11.2 Disposal

- The equipment wrapping is potentially recyclable.
- The metal parts are used for scrap metal recycling.
- The plastic parts are used for plastic recycling.
- Electric components and printed circuit boards are disposed of as electronic scrap.
- Exhausted or damaged batteries can be returned to your medical equipment supplier or Invacare.
- Disposal must be carried out in accordance with the respective national legal provisions.
- Ask your city or district council for details of the local waste management companies.

12 Technical data

12.1 Technical specifications

The technical information provided hereafter applies to a standard configuration or represents maximum achievable values. These can change if accessories are added. The precise changes to these values are detailed in the sections for the respective accessories.

Permissible operating and storage conditions	
Temperature range for operation according to ISO 7176-9:	• -25° ... +50 °C
Temperature range for storage according to ISO 7176-9:	• -40° ... +65 °C

Electrical system	
Motors	<ul style="list-style-type: none"> • 340 W (conventional motors) • 600 W (GB motors)
Batteries	• 2 x 12 V/73.5 Ah (C20) leakproof/gel
Main fuse	• 80 A

Battery charger	
Output current	8 A ± 8 %
Output voltage	24 V nominal (12 cells)
Input voltage	230 – 240 V
Operating temperature (surroundings)	-5° ... +40 °C
Storage temperature	-20° ... +50 °C

Drive wheel tires		
Tire type	<ul style="list-style-type: none"> 3.00 - 8" pneumatic, puncture-protected or puncture-proof 	<ul style="list-style-type: none"> Trelleborg 8x3.00 pneumatic or puncture-protected
Tire pressure	<p>The recommended maximum tire pressure in bar or kpa is marked on the side wall of the tire or the rim. If more than one value is listed, the lower one in the corresponding units applies.</p> <p>(Tolerance = -0.3 bar, 1 bar = 100 kpa)</p>	

Caster tires		
Tire type	<ul style="list-style-type: none"> 3.00 - 6 pneumatic, puncture-protected or puncture-proof 	
Tire pressure	<p>The recommended maximum tire pressure in bar or kpa is marked on the side wall of the tire or the rim. If more than one value is listed, the lower one in the corresponding units applies.</p> <p>(Tolerance = -0.3 bar, 1 bar = 100 kpa)</p>	

Driving characteristics		
Speed	<ul style="list-style-type: none"> 6 km/h 10 km/h 13 km/h 	
Min. braking distance	<ul style="list-style-type: none"> 1000 mm (6 km/h) 2100 mm (10 km/h) 3400 mm (13 km/h) 	
Max. safe slope ¹ :		
	without lifter	<ul style="list-style-type: none"> 11.3° (20 %) according to manufacturer's specifications with 150 kg payload, 4° seat angle, 20° backrest angle
	with lifter	<ul style="list-style-type: none"> 8° (15 %) according to manufacturer's specifications with 150 kg payload, 4° seat angle, 20° backrest angle

Driving characteristics	
Max. climbable obstacle height	<ul style="list-style-type: none"> • 100 mm (with curb climber) • 60 mm (without curb climber)
Turning diameter	<ul style="list-style-type: none"> • 1770 mm
Turning width	<ul style="list-style-type: none"> • 1100 mm
Drive range in accordance with ISO 7176-4:2008 ²	<ul style="list-style-type: none"> • 36 km (Storm 4) • 42 km (Storm 4 X-plore) • 59 km (Storm 4 True Track)

Dimensions in accordance with ISO 7176-15	Standard	Easy-Adapt	Matrx
Total height	<ul style="list-style-type: none"> • 970 mm 	<ul style="list-style-type: none"> • 1050 mm 	<ul style="list-style-type: none"> • 970 mm
Drive unit width	<ul style="list-style-type: none"> • 630 - 770 mm 		
Total length (incl. standard legrests)	<ul style="list-style-type: none"> • 1190 mm 		
Total length (without standard legrests)	<ul style="list-style-type: none"> • 910 mm 		
Seat height ³ (with lifter)	<ul style="list-style-type: none"> • 400 - 650 mm (Storm 4) • 440 - 690 mm (Storm 4 X-plore) 		
Seat height ³ (without lifter)	<ul style="list-style-type: none"> • 450/480 mm 		
Seat width	<ul style="list-style-type: none"> • 380 - 530 mm 		
Seat depth	<ul style="list-style-type: none"> • 380 - 530 mm 		
Backrest height ³	<ul style="list-style-type: none"> • 480/540 mm 	<ul style="list-style-type: none"> • 650 mm 	<ul style="list-style-type: none"> • 500 mm
Backrest angle	<ul style="list-style-type: none"> • 80°, 90°, 97,5°, 105°, 112,5°, 120° (man.) 	<ul style="list-style-type: none"> • 85°...125° 	
Armrest height	<ul style="list-style-type: none"> • 250-340/290-380 mm 		

Dimensions in accordance with ISO 7176-15	Standard	Easy-Adapt	Matrix
Legrest length	• 290 - 460 mm		
Legrest angle	• 0° ... 75°		
Seat angle, electrical adjustment	• 0° - 25°		
Seat angle, manual adjustment	• 0° - 9°		

Dimensions	RECARO	Optimist	Modulite
Total height	• 970 mm	• ca. 970 mm ⁴	<ul style="list-style-type: none"> • 1020 mm (single-part seat frame) • 1090 - 1190 mm (telescopic seat frame, moving the backrest plate)
Drive unit width	• 630 - 770 mm		
Total length (incl. standard legrests)	• 1190 mm	• ca. 1190 mm ⁴	• 1190 mm
Total length (without standard legrests)	• 910 mm	• ca. 910 mm ⁴	• 910 mm
Seat height ³ (with lifter)	<ul style="list-style-type: none"> • 400 - 650 mm (Storm 4) • 440 - 690 mm (Storm 4 X-plore) 		
Seat height ³ (without lifter)	• 450/480 mm		

Dimensions	RECARO	Optimist	Modulite
Seat width	<ul style="list-style-type: none"> • 490 - 530 mm 	<ul style="list-style-type: none"> • see manufacturer's data⁴ 	<ul style="list-style-type: none"> • 380 mm (380 - 430 mm) • 430 mm (430 - 480 mm) • 480 mm (480 - 530 mm) • 530 mm (530 - 580 mm)
Seat depth	<ul style="list-style-type: none"> • 460 - 510 mm 		<ul style="list-style-type: none"> • 410 - 510 mm
Backrest height ³	<ul style="list-style-type: none"> • 770 - 830 mm 		<ul style="list-style-type: none"> • 480/540 mm (sling back) • 560 - 660 mm (telescopic seat frame, moving the backrest plate)
Backrest angle	<ul style="list-style-type: none"> • 90° ... 135° 		<ul style="list-style-type: none"> • 90° ... 120°
Armrest height	<ul style="list-style-type: none"> • 250-340/290-380 mm 		<ul style="list-style-type: none"> • 290 - 360 mm
Legrest length	<ul style="list-style-type: none"> • 290 - 460 mm 		<ul style="list-style-type: none"> • 290 - 460 mm
Legrest angle	<ul style="list-style-type: none"> • 0° ... 75° 		<ul style="list-style-type: none"> • 0° ... 75°
Seat angle, electrical adjustment	<ul style="list-style-type: none"> • 0° - 25° 		
Seat angle, manual adjustment	<ul style="list-style-type: none"> • 0° - 9° 		

Weight

Kerb weight ⁵	<ul style="list-style-type: none"> • at least 174 kg
--------------------------	---

Component weights

Batteries	<ul style="list-style-type: none"> • approx. 24.5 kg per battery
-----------	---

Payload

Max. payload	<ul style="list-style-type: none"> • 150 kg
--------------	--

Axle loads	
Max. front axle load	• 200 kg
Max. rear axle load	• 300 kg

- 1 Static stability according to ISO 7176-1 = 9° (15.8 %)
Dynamic stability according to ISO 7176-2 = 6° (10.5 %)
- 2 Note: The drive range of an mobility device is strongly influenced by external factors, such as the charging state of the batteries, surrounding temperature, local topography, road surface characteristics, tire pressure, weight of driver, drive style and use of batteries for lighting, servos etc.
The specified values are theoretical maximum achievable values measured according to ISO 7176-4:2008.
- 3 Measured without seat cushion
- 4 Dependent on the seat dimensions. See the manufacturer's data on www.ajstole.dk
- 5 The actual curb weight depends on the fittings your mobility device has been supplied with. Every Invacare mobility device is weighed when leaving the works. Please refer to the nameplate for the curb weight (including batteries) measured.

Notes

Notes

Invacare Sales Companies

Australia:

Invacare Australia PTY. Ltd.
1 Lenton Place, North Rocks N.S.W.
2151, Sydney, Australia
Tel. +61-2-8839-5333
Fax +61-2-8839-5353
sales@invacare.com.au
www.invacare.com.au

United Kingdom:

Invacare Limited
Pencoed Technology Park, Pencoed
Bridgend CF35 5AQ
Tel: (44) (0) 1656 776 222
Fax: (44) (0) 1656 776 220
uk@invacare.com
www.invacare.co.uk

Canada:

Invacare Corporation
570 Matheson Blvd E Unit 8
Mississauga Ontario
L4Z 4G4 Canada
800-668-5324

Eastern Europe & Middle East:

Invacare GmbH, EDO
Kleiststraße 49
D-32457 Porta Westfalica
Tel: (49) (0)57 31 754 540
Fax: (49) (0)57 31 754 541
edo@invacare.com
www.invacare.eu.com

Ireland:

Invacare Ireland Ltd,
Unit 5 Seatown Business Campus
Seatown Road, Swords, County Dublin
Tel : (353) 1 810 7084
Fax: (353) 1 810 7085
ireland@invacare.com
www.invacare.ie

New Zealand:

Invacare New Zealand Ltd
4 Westfield Place, Mt Wellington,
Auckland
Tel: 0064 9 917 3939
Fax: 0064 9 917 3957
sales@invacare.co.nz
www.invacare.co.nz



Manufacturer:

Invacare Deutschland GmbH
Kleiststraße 49
32457 Porta Westfalica

1529686-P 2014-08-01



Making Life's Experiences Possible™



Yes, you can.®